

GUIDE

GUIDE Inverter HF630-L (MT) Series Technical Manual

Version: 1.06

Ensure the end user receives this manual and keep it properly.

Wuhan Guide Technology Co., Ltd.

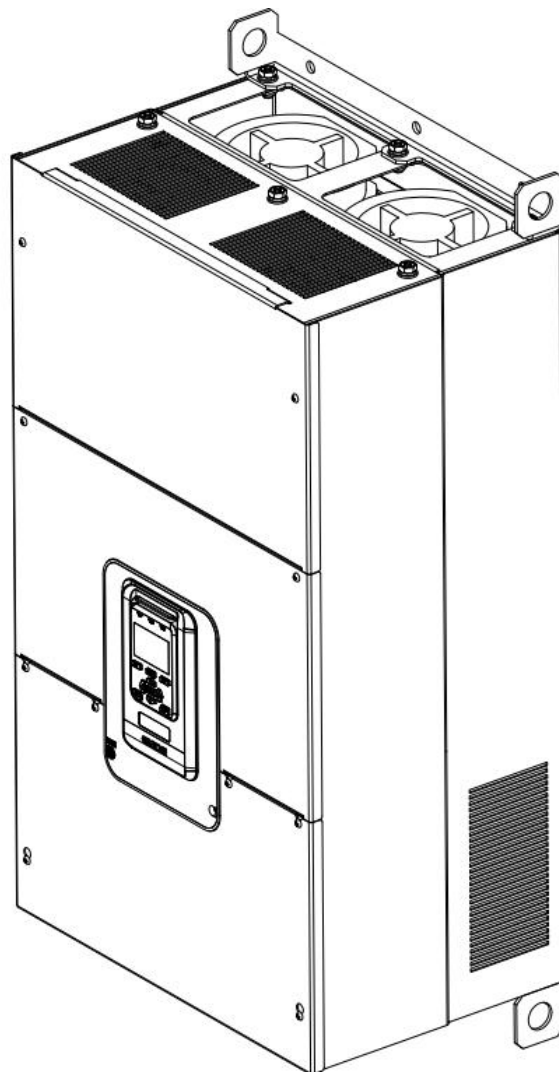

Foreword

Thank you for your choice on GUIDE inverter! You will enjoy our comprehensive and sincere service.

The vector controlled GUIDE HF630 Series inverter, have been developed to satisfy the high reliability and high inverter performance demands in crane industry, with its sensorless vector control performance indexes reaching the world's leading level.

In order to guarantee the inverter's excellent performance and safety of the user and equipment, read carefully this manual before attempting to start the equipment.

This manual is attached with the product as an accessory; keep it well for future inspection and maintenance.

Do not hesitate to contact our local offices and agencies in case of any doubt or special requests, and it is also available to contact directly our aftersales department service center in Wuhan headquarter, we will offer our service sincerely.

Contents of this manual are subject to change without notice.

Wuhan Guide Technology Co.,Ltd.

Content

1 Safety instructions.....	1
1.1 Symbols.....	1
1.2 Application scope.....	2
1.3 Notice on scrapping.....	2
2. Product overview.....	3
2.1 Unpacking check.....	3
2.2 Product model and nameplate.....	3
2.3 Product series models and technical specification.....	4
2.4 Product appearance and components name.....	5
Product dimensions.....	11
2.6 Product comprehensive performance indexes.....	17
2.7 Main technical features.....	19
2.8 Optional accessories description.....	19
3. Inverter storage and installation.....	21
3.1 Storage and installation environment.....	21
3.2 Installation direction and space.....	23
3.3 Detachment and installation of cover plate.....	32
3.4 Installation of adjunct card.....	33
3.5 Wiring instruction of PGC2 card.....	34
3.6 Wiring instruction of PGD2 card.....	37
4. Inverter wiring.....	41
4.1 Notice on wiring.....	41
4.2 Wiring for main circuit terminals.....	42
4.3 Control circuit terminals.....	45
4.4 Basic wiring plan of inverter.....	48
4.5 Input signal wiring plan.....	49
4.6 System wiring plan.....	50
4.7 Wiring Specification.....	51
4.8 Input/output AC reactor selection.....	52
4.9 Brake resistance selection.....	53
4.10 Installation instructions conform to EMC requirements.....	54
5. Operation instructions.....	59
5.1 Operation panel instruction.....	59
5.2 Access Permissions.....	60
5.3 Key operation.....	61
5.4 Main menu configuration diagram.....	61
5.5 《option》 Menu configuration description.....	65
5.6 《menu》 Menu configuration description.....	66
6. Inverter test run.....	70
6.1 Inverter test run sequence.....	70
6.2 Inverter test run operation.....	71
6.2.1 Energization.....	71
6.2.2 Display status confirmation.....	71
6.2.3 Parameter initialization.....	72
6.2.4 Parameter setting.....	72
6.2.5 Motor parameter auto-tuning.....	73
6.2.6 Notice before auto-tuning mode.....	74
6.2.7 No-load operation test run.....	75

6.2.8 Test run with load connected.....	76
6.2.9 Parameter save.....	77
7. Inverter parameter setting instruction.....	78
7.1 Initializing parameter control P0.....	78
7.2 Parallel inverter and panel observation configuration P2.....	78
7.3 Digital input set of terminals P3.....	79
7.4 Digital Output set of terminals P4.....	80
7.5 Analog input set of terminals P5.....	83
7.6 Analog output set of terminals P6.....	84
7.7 Protection setting P7.....	86
7.8 Motion Control 1 P8.....	89
7.9 Motion Control 2 P9.....	92
7.10 Motion Control 3 P10.....	95
7.11 Motion Control 4 P11.....	98
7.12 Motor 1 Step Speed Brake Set P12.....	101
7.13 Motor 2 Step Speed Brake Set P13.....	102
7.14 Motor 3 Step Speed Brake Set P14.....	104
7.15 Motor 4 Step Speed Brake Set P15.....	106
7.16 Motor 1 Parameter V/F Set P16.....	107
7.17 Motor 2 Parameter V/F Set P17.....	110
7.18 Motor 3 Parameter V/F Set P18.....	114
7.19 Motor 4 Parameter V/F Set P19.....	117
7.20 Motor 1 Vector Control Set P20.....	120
7.21 Motor 2 Vector Control Set P21.....	125
7.22 Motor 3 Vector Control Set P22.....	129
7.23 Motor 4 Vector Control Set P23.....	134
7.24 MODBUS P32.....	138
7.25 PROFIBUS DP P33.....	139
8. Specified parameter function description.....	149
8.1 Parallel running and panel observation setting.....	149
8.2 Digital input.....	149
8.3 Digital output.....	150
8.4 Analog input.....	151
8.5 Analog output.....	151
8.6 Protection parameter.....	152
8.7 Motor start/stop control parameters.....	156
8.8 Motor multi-speed and brake control.....	159
8.9 Motor basic parameters and V/F control parameters.....	160
8.10 Motor vector control parameters.....	164
9. Abnormality solutions and inspection.....	172
9.1 Alarm codes.....	172
9.2 Error codes.....	174
9.3 Error diagnosis.....	178
10. Maintenance.....	180
10.1 Maintenance instructions.....	180
10.2 Routine maintenance.....	181
10.3 Periodic maintenance.....	181
10.4 Displacement of wearing elements.....	182
10.5 Storage and guarantee.....	182

1 Safety instructions

Read carefully this manual before installation, running, maintenance and inspection of the inverter.

1.1 Symbols



Danger

When misused, it will result in danger, serious injury or death.



Notice

When misused, it can cause danger, which may result in minor or moderate personal injury or equipment damage.



Warning

- (1) It is prohibited to touch the heat sink 10 minutes after power on or a while after power off to prevent getting burnt;
- (2) Do not operate the drive on and off frequently and re-energization is prohibited within five minutes after power switched on again;
- (3) Do not remove the drive cover or touch the printed circuit board under power on state to prevent electric shock;
- (4) Workings as wiring and inspections should be carried out only after the power is turned off ten minutes;
- (5) The inverter ground terminal should be firmly grounded;
- (6) No object is allowed to drop into the inverter.



Danger

- (1) The inverter is prohibited to be installation on flammable objects;
- (2) This series of inverters are not suitable in flammable and combustible environment, if needed such special orders, please contact us;
- (3) It is not allowed to dismantle or refit the inverter privately;
- (4) It is prohibited to connect AC power to the inverter output terminals-U, V, W;

1.2 Application scope

- (1) This product is a specialized vector-control inverter for cranes which is used for industrial 3 phase AC asynchronous motors.
- (2) The equipment (such as nuclear control systems, aviation systems, safety devices and gauges) that may cause injuries or death due to Inverter malfunction should be treated carefully. Consult the company in such cases.
- (3) The inverter is fabricated under strict quality control. If it used for hazardous equipment, there should be safety protection measures to prevent situation going worse in case of inverter fault.
- (4) This inverter complies with the following directive and standards:

Directive	Directive Name	Standard
LVD Directive	2014/35/EU	EN 61800-5-1
EMC Directive	2014/30/EU	EN 61800-3

1.3 Notice on scrapping

Special attention should be paid when treating the scrapped inverter and its elements..

Electrolytic capacitor: It may explode during incineration.

Plastic: The plastic and rubber materials of the inverter may produce toxic gas, please pay attention when incineration.

Clearance: Please treat the scrapped inverter as industrial waster.

2. Product overview

2.1 Unpacking check



Warning

- a. Ensure the model selection is correct; otherwise it may cause motor abnormal running or inverter damage.
- b. Do not install or run any inverter that is damaged or with damaged elements, otherwise it will cause danger.

Please check the following items after unpacking:

1. Check whether there is any damage during transportation. (Such as damage to element, elements get loose and damage to main body)
2. Check whether there is manual and guarantee card.
3. Check whether the model(s) conform to your order(s).
4. Check whether the optional accessories conform to your order(s) if there are optional accessories.

Contact immediately the local agency if there is any damage to the inverter or optional accessories.

2.2 Product model and nameplate

Inverter model implication:

HF630		XXX	4	MT
Inverter serial		Power code	Voltage level	Plant code
HF	High Function	OR4: 0.4kW 011: 11kW ...	400V	MT
630	Serial No.	110: 110kW		

Figure 2-1 Model implication

HF630 series inverter nameplate is as shown in graphic 2-2(15KW).



MODEL: 84072083
 POWER: 15kW
 RATED CURRENT: 32A
 INPUT: AC3PH 380V-480V 50/60Hz
 OUTPUT: AC3PH 0-480V 0-300Hz

Inverter

Product ID.



D4015008CK002

E- STAND: V1

MODEL: 84072083 indicates: This is HF630 series inverter, voltage level 400V.

AC: It indicates alternative current power input and output.

3PH: It indicates three phase input and output.

380-480V 50/60Hz: It indicates rated input voltage and frequency.

0-480V 0-300Hz: It indicates the output voltage range and output frequency range of the inverter.

2.3 Product series models and technical specification

Table 2-3 Table sheet for inverter HF630 series

Figure 2-2 Nameplate implication

Model	Light overload		Heavy overload		Type	Weight (Kg)
	Current [A]	Power [kW]	Current [A]	Power [kW]		
HF630-0R4-4MT	1.8	0.4	--	--	I1	3
HF630-0R7-4MT	3.3	0.75	1.8	0.4		
HF630-1R5-4MT	4.8	1.5	3.3	0.75		
HF630-2R2-4MT	5.7	2.2	4.8	1.5	I2	3.5
HF630-3R7-4MT	10.2	3.7	5.7	2.2		
HF630-5R5-4MT	15	5.5	10.2	3.7		

HF630-7R5-4MT	18	7.5	15	5.5		
HF630-011-4MT	24	11	18	7.5	I3	4.5
HF630-015-4MT	32	15	24	11		
HF630-018-4MT	41	18.5	32	15		
HF630-022-4MT	47	22	41	18.5	I4	10.5
HF630-030-4MT	65	30	47	22		
HF630-037-4MT	75	37	65	30	I5	35
HF630-045-4MT	94	45	75	37		
HF630-055-4MT	115	55	94	45		
HF630-075-4MT	155	75	115	55	I6	52
HF630-090-4MT	188	90	155	75		
HF650-110-4MT	215	110	188	90	I7	108.5
HF650-132-4MT	265	132	215	110		
HF650-160-4MT	330	160	265	132		
HF650-185-4MT	365	185	330	160	I8	146
HF650-220-4MT	438	220	365	185		

Note:

Light-overload conditions: overload capacity is 120% of the rated output current, and one minute overload is allowed every 5 minutes.

Heavy overload conditions: overload capacity is 150% of the rated output current, and one minute overload is allowed every 5 minutes.

2.4 Product appearance and components name

HF630 series high-power inverter shell is made of metal material, the surface is sprayed with plastic, and the plane is bright; The small-power inverter shell is molded with plastic, which has a beautiful appearance.

The following graphic shows HF630-0R4-4MT to HF630-7R5-4MT.

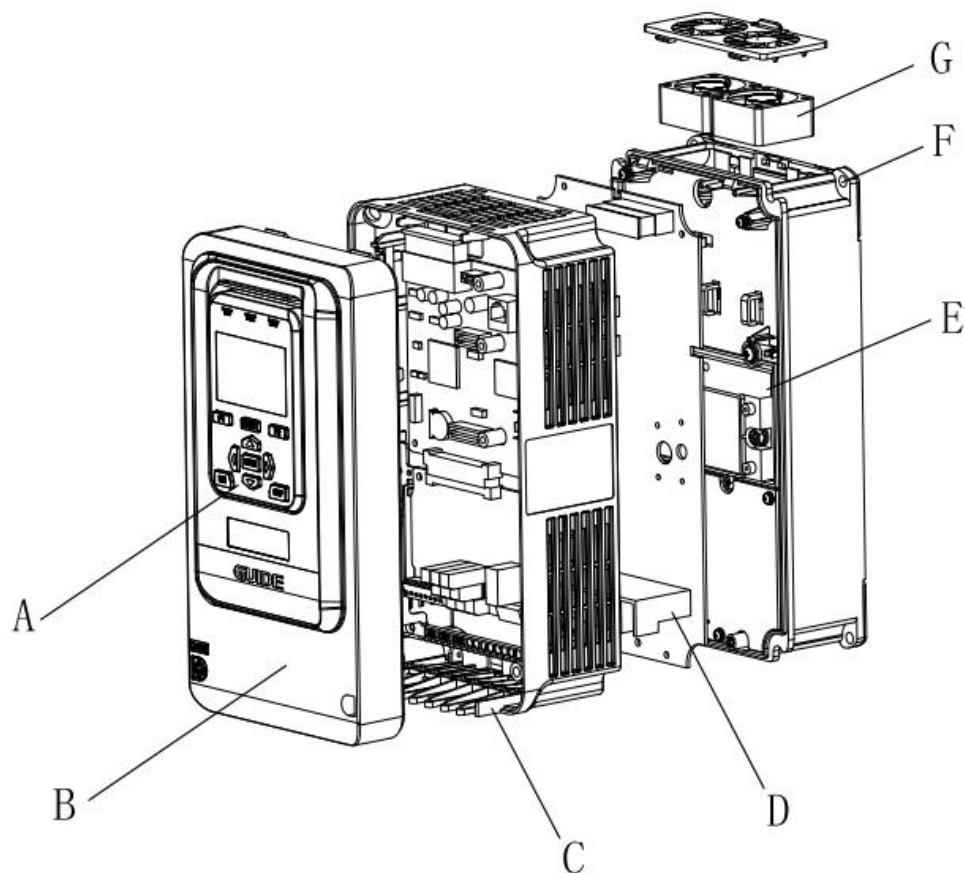

A- Operator B- Cover plate C- Grille D- Main terminal

E- Radiator F- Installation hole G- Cooling fan

HF630-011-4MT to HF630-018-4MT

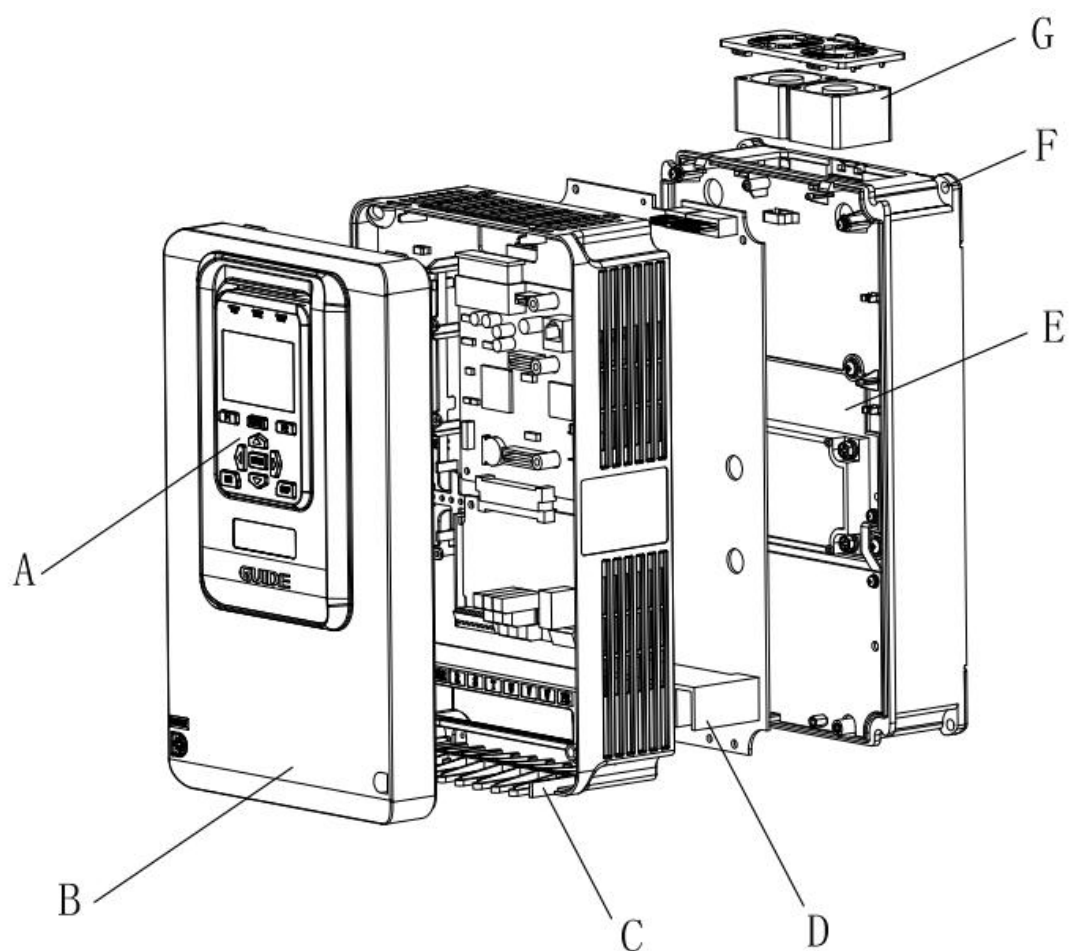

A- Operator B- Cover plate C- Grille D- Main terminal

E- Radiator F- Installation hole G- Cooling fan

HF630-022-4MT to HF630-030-4MT

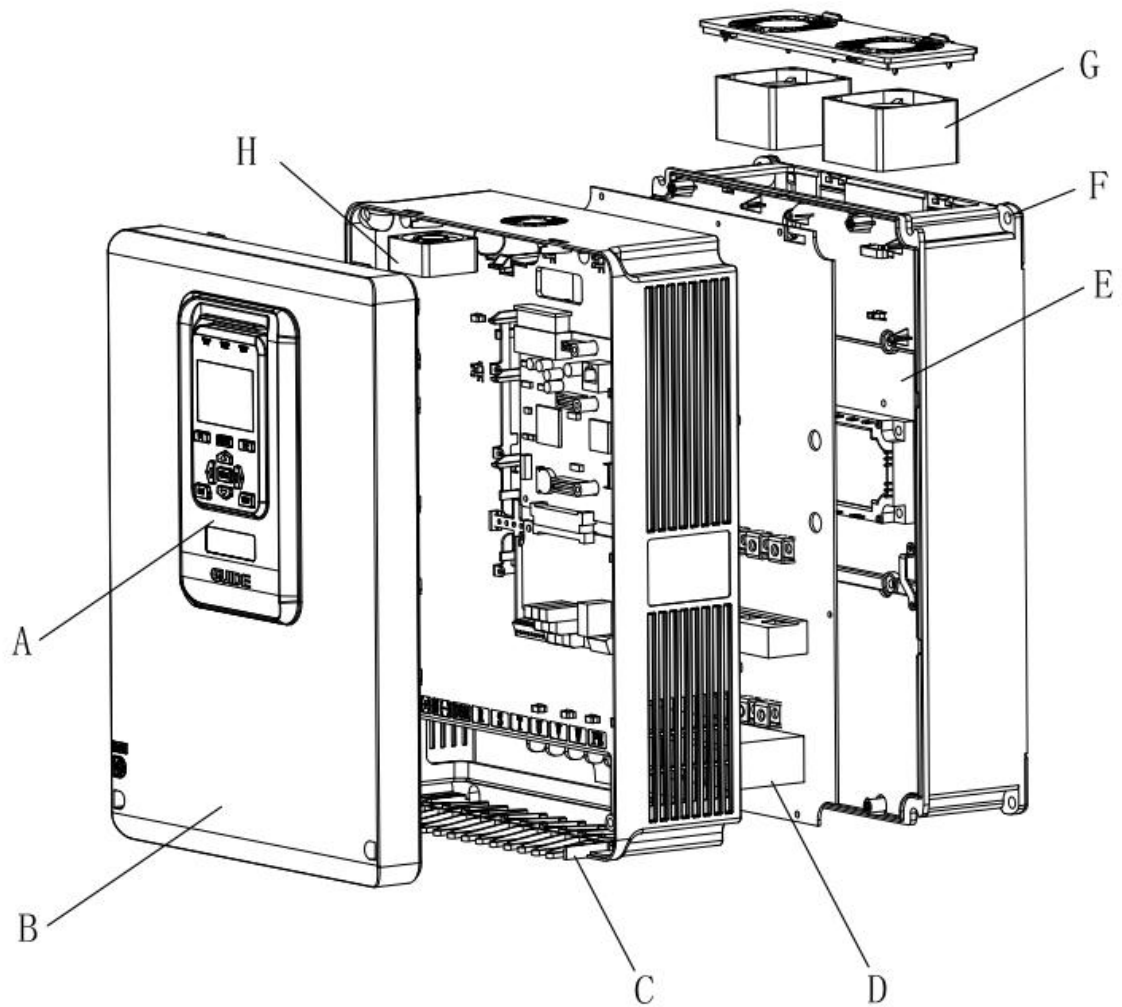

A- Operator B- Cover plate C- Grille D- Main terminal

E- Radiator F- Installation hole G- Cooling fan1 H- Cooling fan2

HF630-037-4MT to HF630-090-4MT

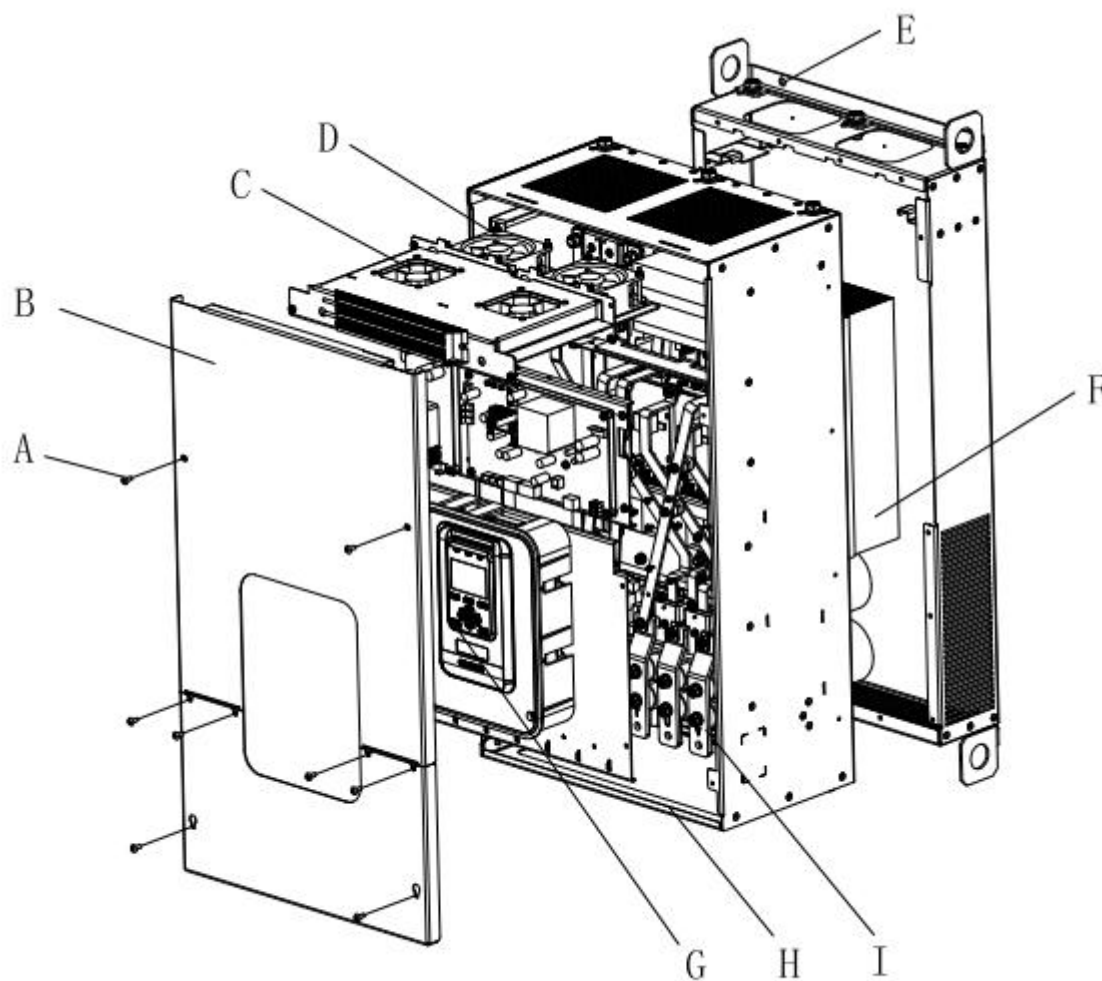

A- Cover plate bolt B- Cover plate C- Cooling fan1 D- Cooling fan2

E- Installation hole F- Radiator G- Operator H- Grille I- Main

terminal

HF650-110-4MT to HF650-220-4MT

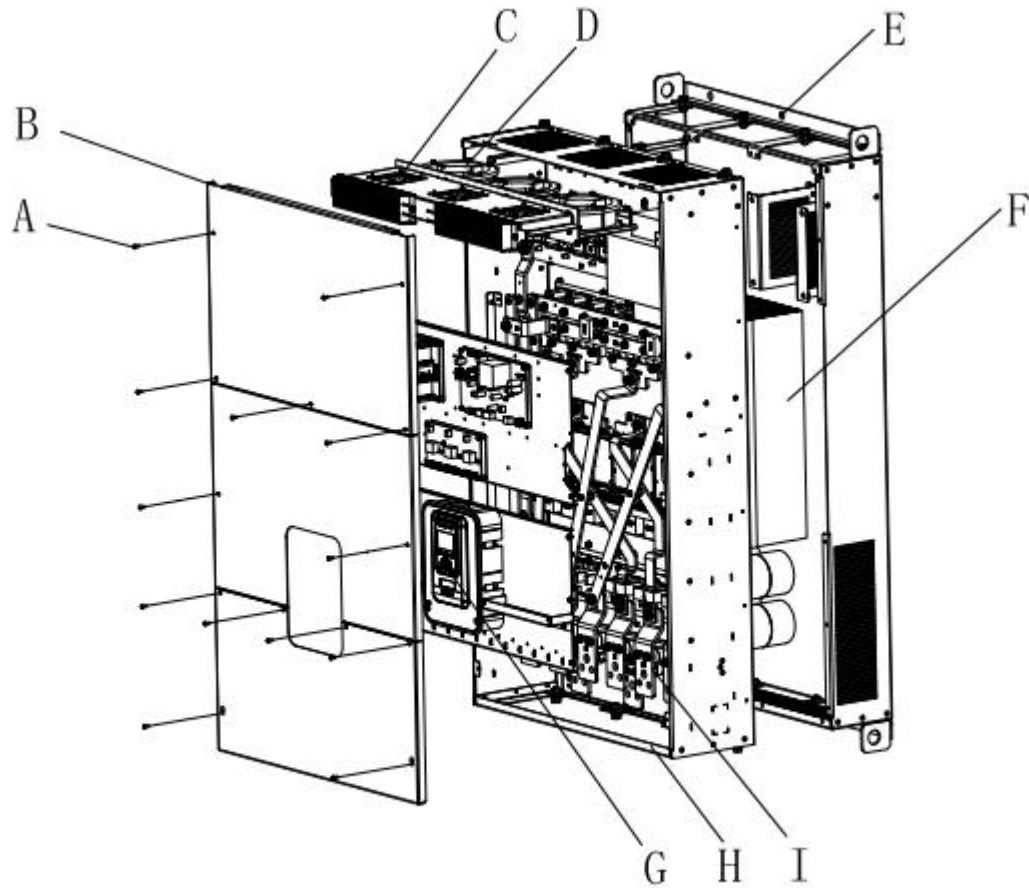

A- Cover plate bolt B- Cover plate C- Cooling fan1 D- Cooling fan2
E- Installation hole F- Radiator G- Operator H- Grille I- Main
terminal

Product dimensions

Inverter dimension diagram

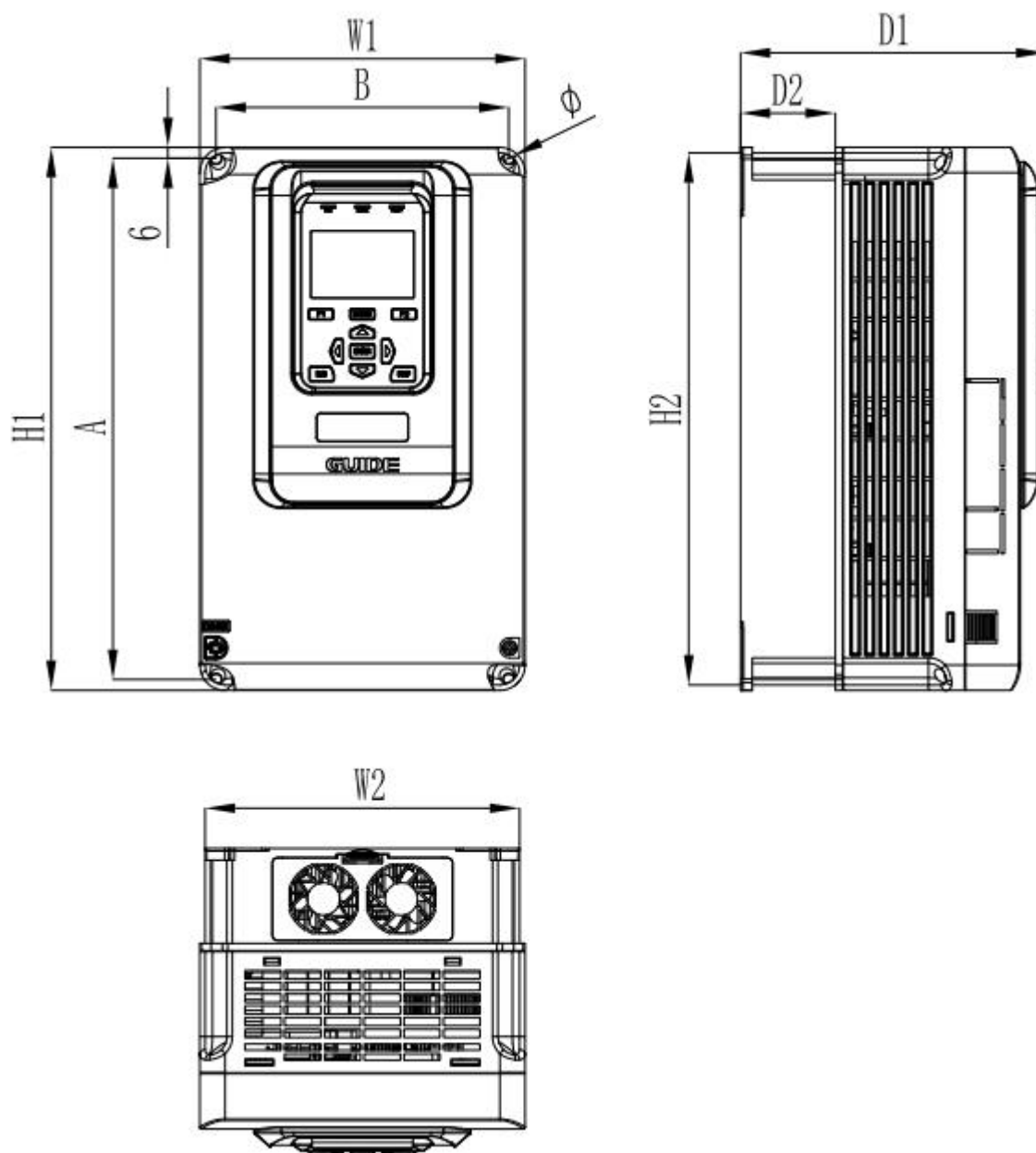

I1-I3 model diagram

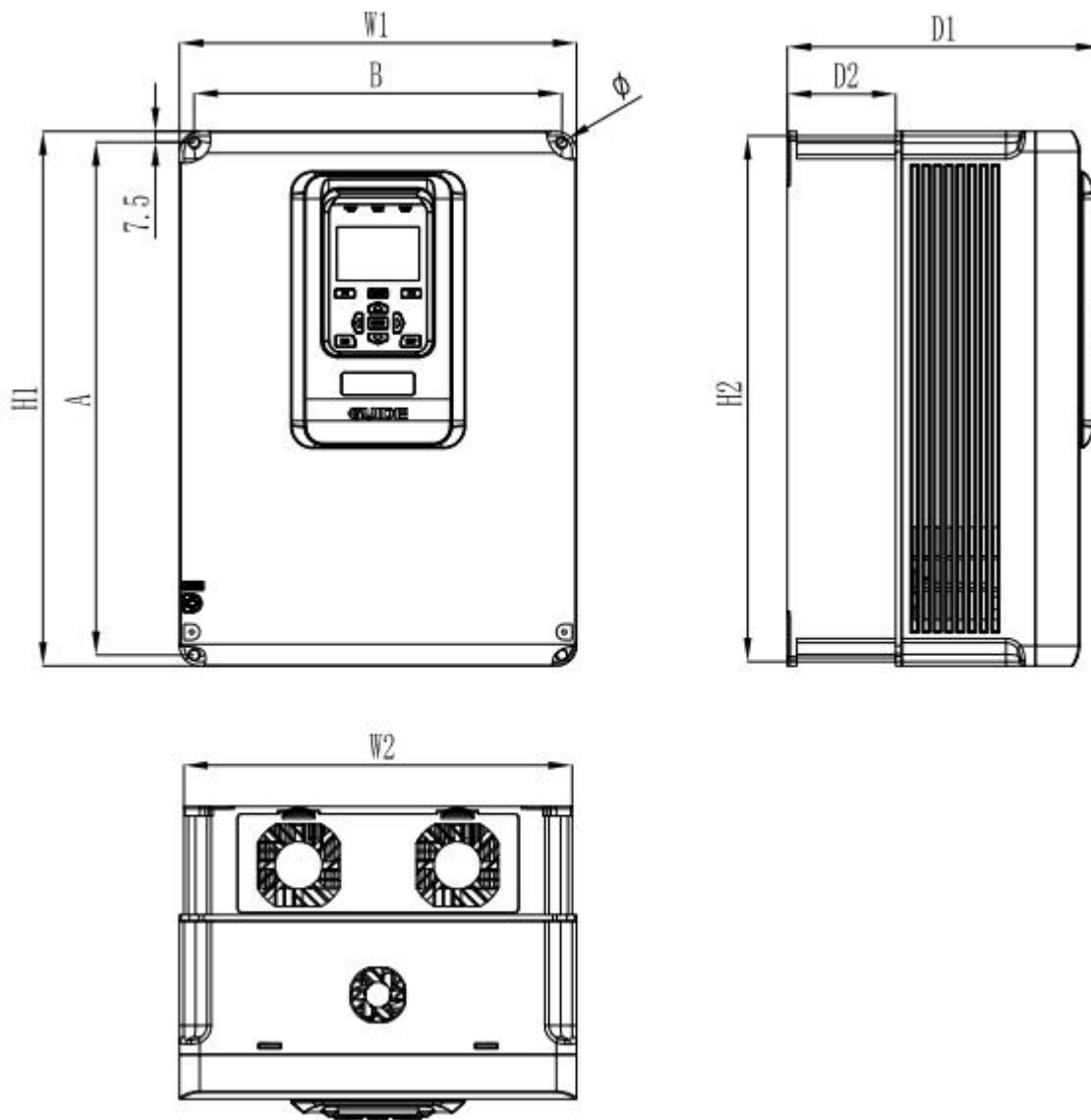

I4 model diagram

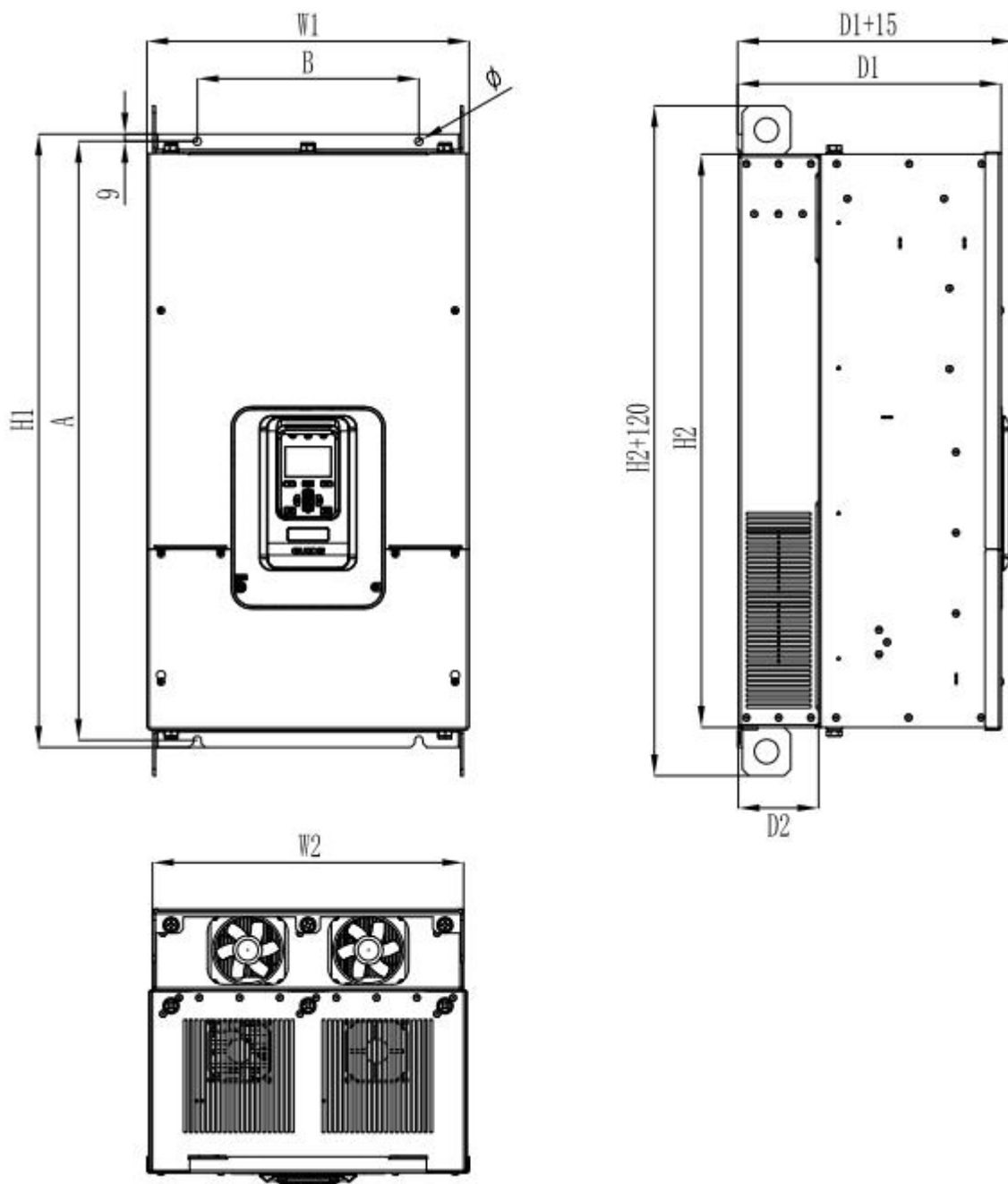

I5-I6 model diagram

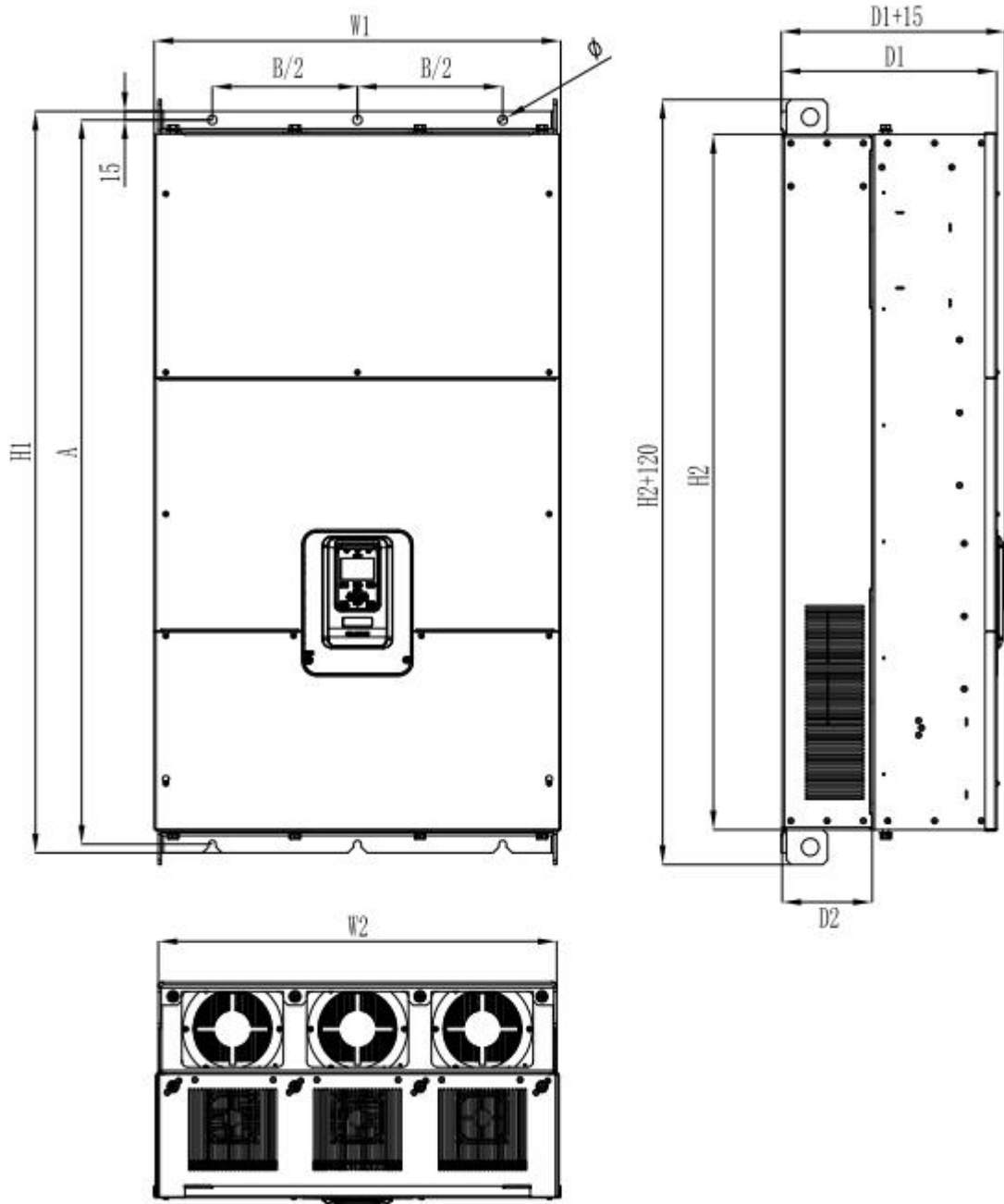

I7 model diagram

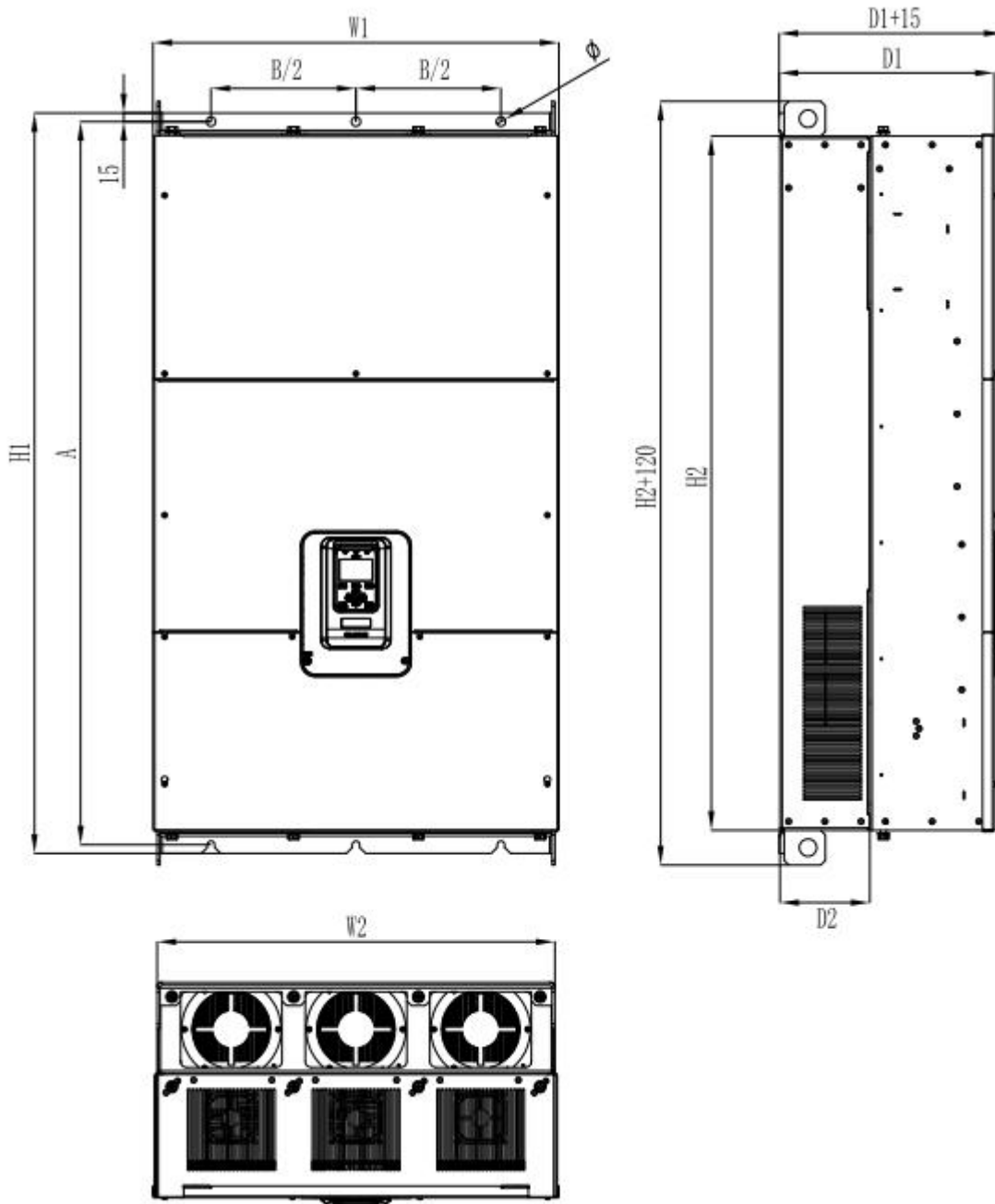

I8 model diagram

Appearance and installation dimensions

Model	Power	Appearance dimensions (Unit:mm)						install dimensions (Unit: mm)		Hole Dia. ϕ	Recomm. Install bolt (Level 8.8) M	Wgh (Kg)
		H1	H2	W1	W2	D1	D2	A	B			
I1	0.4KW	260	254	140	134	170	52.5	248	122	4- ϕ 6	4-M5	3
	0.75KW											
	1.5KW											
I2	2.2KW	260	254	140	134	170	52.5	248	122	4- ϕ 6	4-M5	3.5
	3.7KW											
	5.5 KW											
	7.5 KW											
I3	11 KW	300	294	180	174	170	52.5	288	162	4- ϕ 6	4-M5	4.5
	15 KW											
	18.5KW											
I4	22 KW	370	364	275	269	215	75	355	255	4- ϕ 7	4-M6	10.5
	30 KW											
I5	37 KW	600	565	340	326	282	110	585	225	2- ϕ 9	4-M8	35
	45 KW											
	55 KW											
I6	75 KW	760	710	400	386	327	100	742	275	2- ϕ 9	4-M8	52
	90 KW											
I7	110KW	930	850	490	476	335	155	900	350	3- ϕ 13	6-M12	108.5
	132KW											
	160KW											
I8	185KW	1140	1060	500	486	355	155	1110	350	3- ϕ 13	6-M12	146
	220KW											

2.6 Product comprehensive performance indexes

Item		Description
Input	Input voltage	3Phase 380-480V
	Rated frequency	50/60Hz
	Allowable voltage fluctuation	-15%~+5%
	Allowable frequency fluctuation	frequency fluctuation range : $f_{LN} \pm 2\%$. frequency fluctuation rate : $\leq 2\% f_{LN}/s$.
Output	Voltage	0~Input voltage
	Voltage unsymmetric	3Phase Voltage unsymmetrical: $\leq 1\%$
	Frequency	0-300Hz
Control Characters	Running command source	Operator control, terminal control and communication control
	Carrier frequency	1kHz~10kHz, adjustable based on temp. & load characters
	Frequency resolution	Digital setting: 0.01Hz; Analog setting: Max. frequency x0.1%
	Control method	Closed loop vector control (VC), Open loop vector control(SVC), V/F Control
	V/F control	Linear type, multipoint type and square type
	Torque control	With or without PG torque control
	Max. speed	300Hz, based on motor' s electrical and mechanical characteristics
	Starting torque	0Hz/180%(VC and SVC)、0.8Hz/150%(V/F)
	Speed regulation range	1:500(SVC)、1:1000(VC)
	Speed accuracy	$\pm 0.02\%$ of rated speed(VC)、 $\pm 0.2\%$ of rated speed (SVC)、 $\pm 0.5\%$ of rated speed (V/F)
	Overload capacity	Ever 5 minute, 120%of rated current for 60S、150% of rated current for60S
	Torque compensation	Automatic torque compensation function
	Acceleration& Deceleration method	Straight line, user defined multipoint curve
	Auto Voltage adjustment	It will automatically hold stably the output voltage when the grid voltage has fluctuation.
	DC brake method	The DC brake acts both in start and stop.
	Built-in Process PID	VC control system that can realize process quantity (pressure, temperature and flow, etc) with convenience.
Communciation	DP、CAN、Modbus、Etrernet、Profinet	
special functions	Logic function module、 Mathematical function modules 、	

		Timer module 、PID module 、 Multi-curve acceleration/deceleration function 、 Timer control run / stop control 、 Power Optimizatio、 Position control of grab crane、 Cranes brake on/off function、 Master / Slave synchronization control 、 speed / torque control 、 Active and reactive current control (AFE parallel operation)
Input/output terminals	Input terminals	8 digital input, 2 analog input (Voltage -10~+10V or Current 0mA/4mA~20mA)
	Output terminals	5 digital output (3 sourcing output and 2 relay output) , 2 analog output (Voltage 0~+10V or Current 0mA/4mA~20mA)
H&M Interface	Operator LCD	It can set corresponding parameters or display output frequency, output voltage and output current, etc
Protection function		Protection for overcurrent, overvoltage, undervoltage, overheat and overload, etc.
Operation location		It is prohibited to be exposed directly under the sun or dusty and corrosive environment.
Ambient environment	Altitude	Below altitude of 1, 000 meters. In areas of altitude over 1000 meters, the rated output should be reduced by 1% each additional 100 meters. In areas of altitude over 3000 meters, please consult manufacturer
	Ambient temp.	Ambient temperature -10 °C ~ +40 °C. If the temperature range is between +40 °C ~ +50 °C, increased by 1 °C, the rated output current is reduced by 3%. If the temperature is more than 50 °C, please consult manufacturer.
	Humidity	Lower than 95%RH without waterdroop condensation.
	Storage temp.	-20°C ~ +60°C
Other	Power factor	Inverter :>0.85; AFE:>0.999
	efficiency	>98%
	Optional accessories description	There are three sockets on control-card . Communication card and IO card can insert to socket J14; IO card can insert to socket J15; PG card can insert to socket J13.
	Other connector	operation keyboard outside of the inverter
	Protection class	IP20
	Cool	Fan
	Contaminate class	2
	Noise	≤80db

2.7 Main technical features

- (1) Both open loop and closed loop vector can reach zero speed with 200% torque output;
- (2) When the load does not exceed 50% of the rated motor load, the GUIDE HF630 inverters can implement auto-tuning with load, under which condition the obtained motor parameters are the same as that obtained under no-load condition;
- (3) GUIDE HF630 inverters own built-in constant power control module: when entering the constant power flux-weakening speed regulation zone, the output frequency is automatically adjusted according to the load;

2.8 Optional accessories description

Name	Type	Description
DP Bus card	GDHF-DP03	GDHF-DP03 bus card conform to Profibus field bus international standards which can be used with HF630 series inverter.
MB Communication card	GDHF-MB02	GDHF-MB02 communication card supports MODBUS-RTU slave protocol with RS485 interface and RS232 interface, providing networked with the RS485 or RS232 MODBUS-RTU interface device, used in conjunction with the HF630 series inverter.
technical card	GDHF-GY02	GDHF-GY02 technical card which can be used with HF630 series inverter.
General PG card	GDHF-PGC2	GDHF-PGC2 General PG card can be used as encoder that connected with inverter's adapter, which can be used with HF630 series inverter. (output DC voltage is 15V)
synchronized PG card	GDHF-PGD2	GDHF-PGD2 synchroniaed PG card can be used as encoder that connected with inverter's adapter, which can be used with HF630 series inverter synchronizing function. (output DC voltage is 15V)
keyboard	GDHF-KV2	GDHF-KV2 keyboard is the second generation of Guide, which is the same with HF630 series inverter built-in keyboard.

PN Card	GDHF-PN02	PROFINET is based on Industrial Ethernet Technology, and according to TCP/IP and IT standard. GDHF-PN02 card supported PROFINET slave protocol, and it is worked with HF630 series Inverter.
---------	-----------	--

3. Inverter storage and installation



Warning!

1. Unqualified personnel who do not comply with the relevant provisions of the "Warning" may cause severe personal injury or substantial property damage. Only qualified professionals certified in equipment design, installation, commissioning and operation is allowed working on this device / system.
2. Input power wire allows only permanent fastening connection and the device must be firmly grounded.
3. Even if the inverter is inoperative, the following terminals can carry dangerous voltages:
 - Power supply terminals R, S, T
 - Terminals that connected to the motor U, V, W
 - DC bus terminals P1, P, N
4. After the power switch off, wait 10 minutes for the inverter to discharge completely before to start the installation.
5. The minimum cross-sectional area of the grounding conductor must be equal to or greater than the power supply cable cross-sectional area.



Notice!

1. When handling the inverter, please hold the bottom of the body.
If only hold the cover plate, there is danger of body falling that may smash foot.
2. Install the inverter on metal board or other nonflammable material board.
Installed at flammable materials, there is danger of fire.
3. When there are more than two inverter installed in the same casing, please set cooling fan, and keep the inlet air temperature below 40°C.
Due to overheating, it may cause fire and other accidents.

3.1 Storage and installation environment

3.1.1 Storage environment

- The inverter must be placed in dry locations with no dust.

- The storage ambient temperature range is $-20\text{ }^{\circ}\text{C}$ to $+60\text{ }^{\circ}\text{C}$.
- The relative humidity is in the range of 0% to 95% and non-condensing.
- The storage environment should be free of corrosive gases and liquids.
- Better to place the inverter on a shelf and packed suitably.
- Better not to store a inverter for a long time that may cause deterioration of electrolytic capacitors, for long-term storage, ensure that it must be energized once a year with energizing time at least five hours, and the input voltage must be slowly increased by the voltage regulator to the rated voltage.

3.1.2 Installation environment

- Mounted vertically inside the cabinet with good indoor ventilation.
- Ambient temperature $-10\text{ }^{\circ}\text{C}$ ~ $+40\text{ }^{\circ}\text{C}$. If the temperature range is between $+40\text{ }^{\circ}\text{C}$ ~ $+50\text{ }^{\circ}\text{C}$, increased by $1\text{ }^{\circ}\text{C}$, the rated output current is reduced by 3%.

If the temperature is more than $50\text{ }^{\circ}\text{C}$, please consult manufacturer.

- Try to avoid high temperature and humidity; humidity should be less than 95% RH, and no rain dropping.
- Do not install the inverter on flammable materials, such as wooden materials.
- Avoid direct sunlight.
- The environment should be free of flammable, corrosive gases and liquids.
- There should be no dust, oily dust, floating fiber and metal particles.
- The installation base should be strong without vibration.
- There should be no Electro Magnetic Interference, and be away from the interference source.
- Below altitude of 1, 000 meters. In areas of altitude over 1000 meters, the rated output should be reduced by 1% each additional 100 meters. In areas of altitude over 3000 meters, please consult manufacturer.

Note: The site installation environmental conditions will affect the

life of the inverter.

3.2 Installation direction and space

3.2.1 Installation direction

In order to facilitate the inverter cooling, the inverter should be installed in a vertical direction. inverter should be installed on wall or in cabinet.

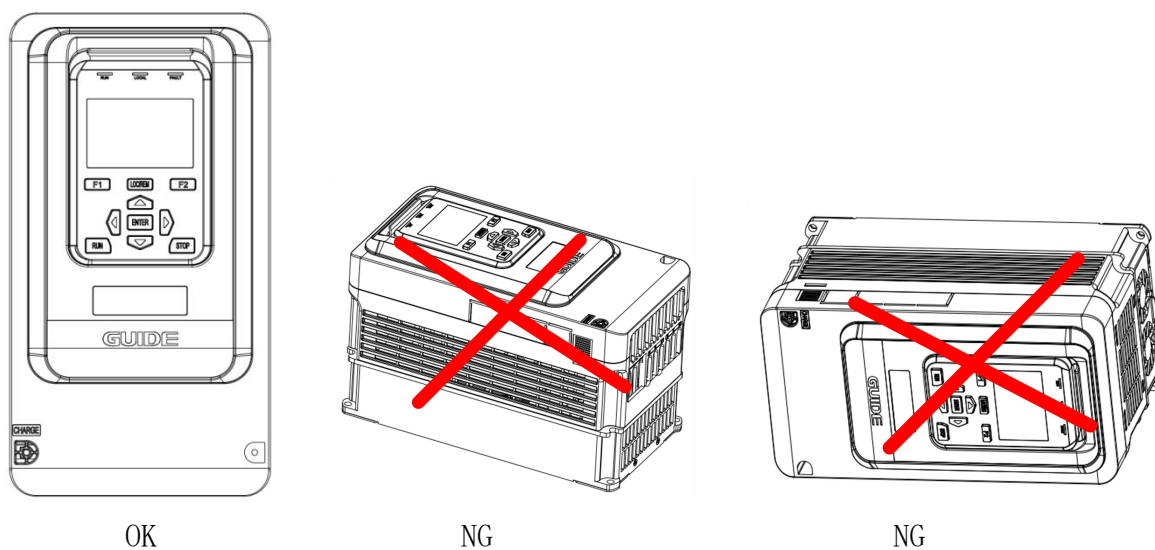

3.2.2 Installation method

There are two installation methods according to dimension of inverter.

(1) installed on wall(for all dimension of inverter)

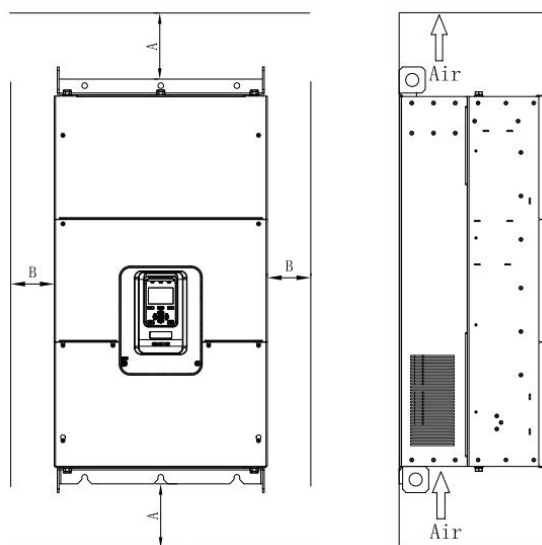

picture 3-1 installed on wall

Ensure the ventilation space. The following table shows the gap size (recommended value) of the inverter installation.

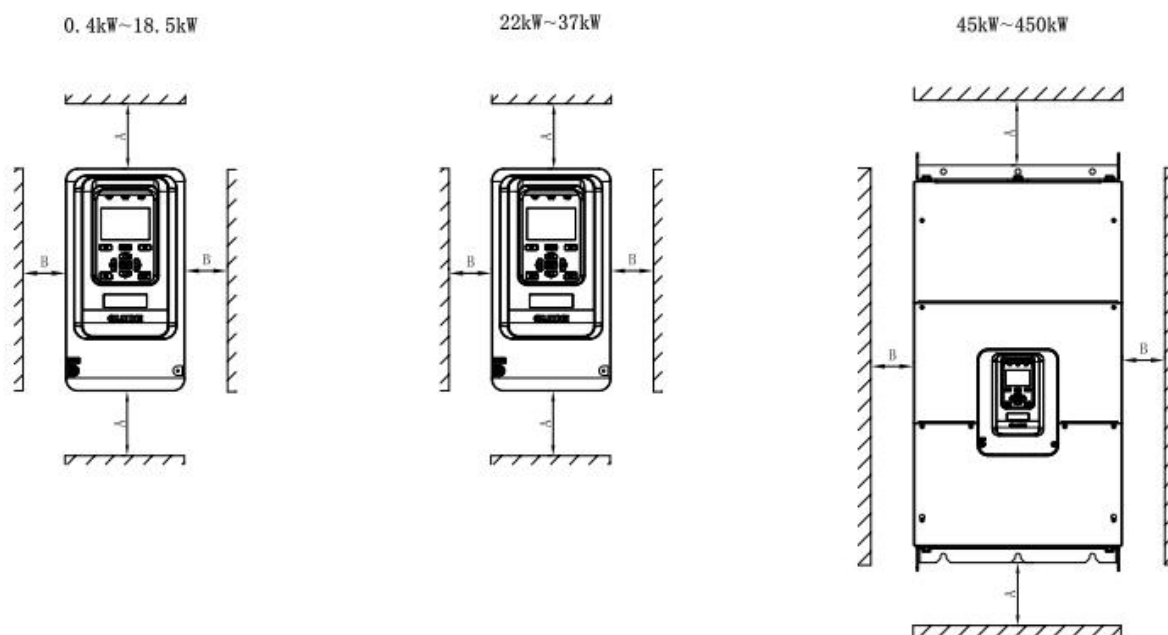

Gap size table

Inverter type	Gap size	
0.4kW~18.5kW	$A \geq 100\text{mm}$	$B \geq 40\text{mm}$
22kW~37kW	$A \geq 200\text{mm}$	$B \geq 50\text{mm}$
45kW~220kW	$A \geq 300\text{mm}$	$B \geq 50\text{mm}$

(2) Installed by inlaying

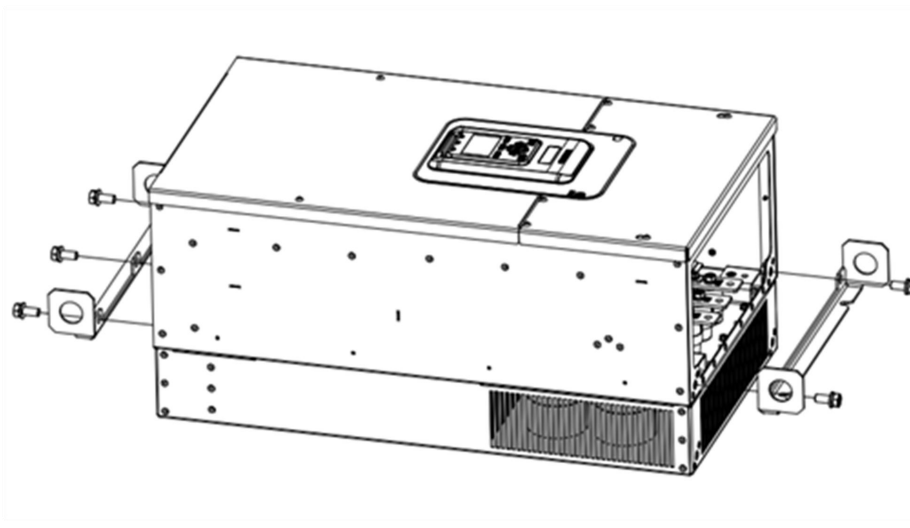

picture 3-2 outside trestle for high-power inverter

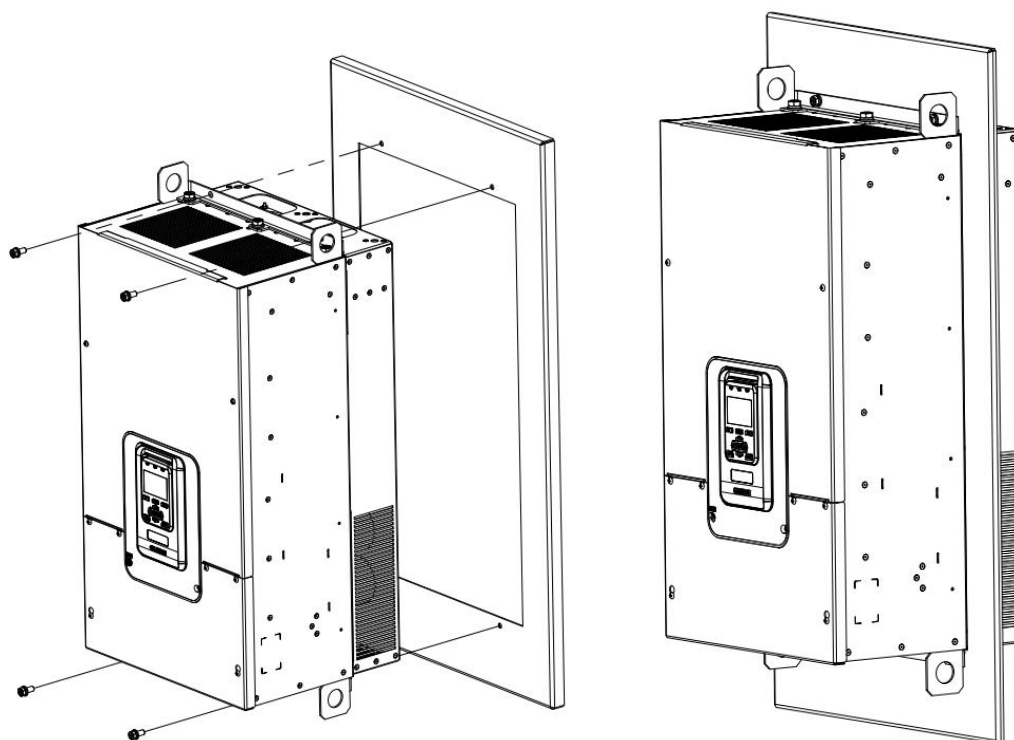

picture 3-3 inlay Installed for high-power inverter

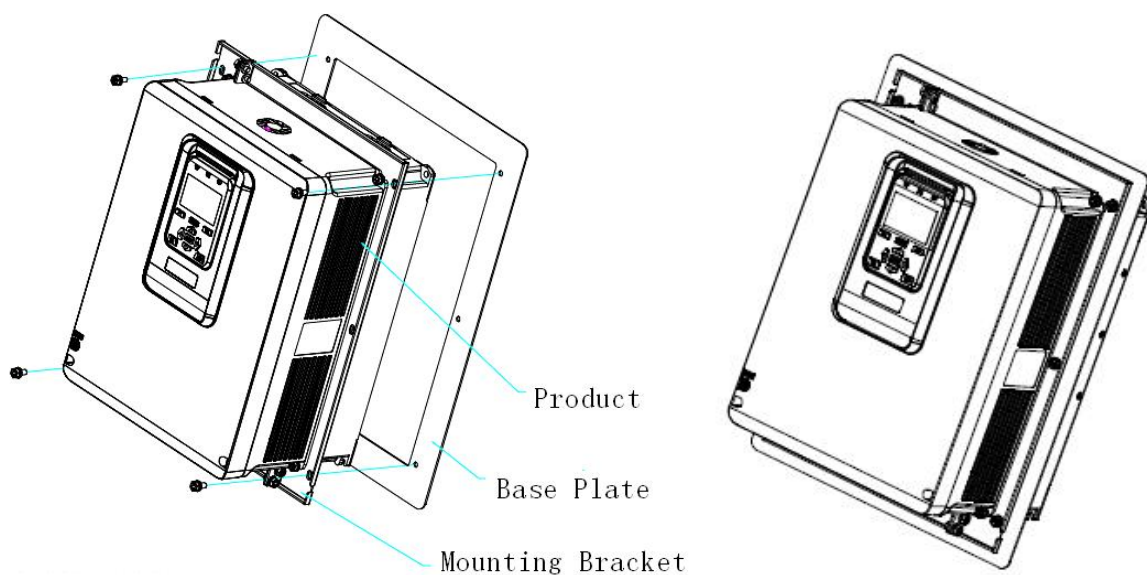

picture 3-4 inlay Installed for small-power inverter

(3) The size of inlaying board

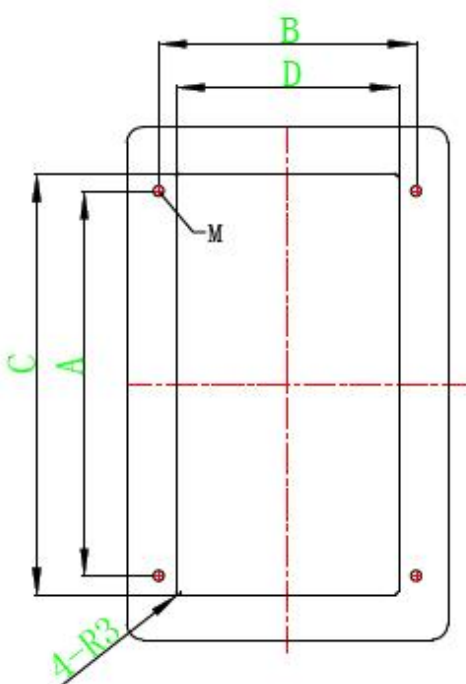

picture 3-5 The size of inlaying board for I1-I2 inverter

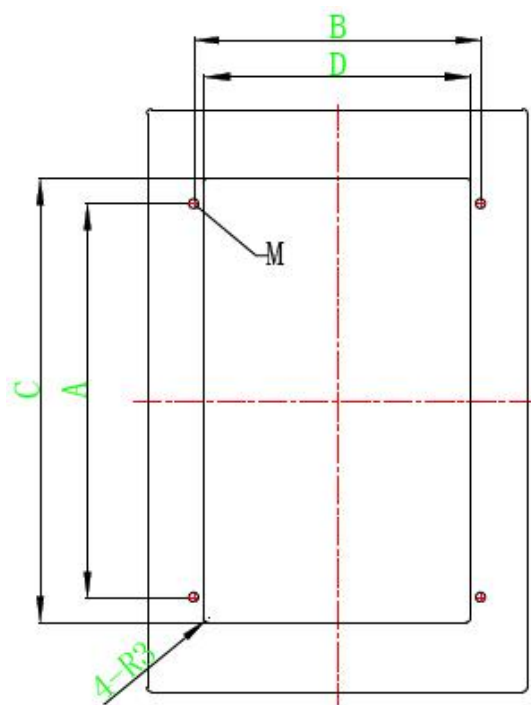

picture 3-6 The size of inlaying board for I3 inverter

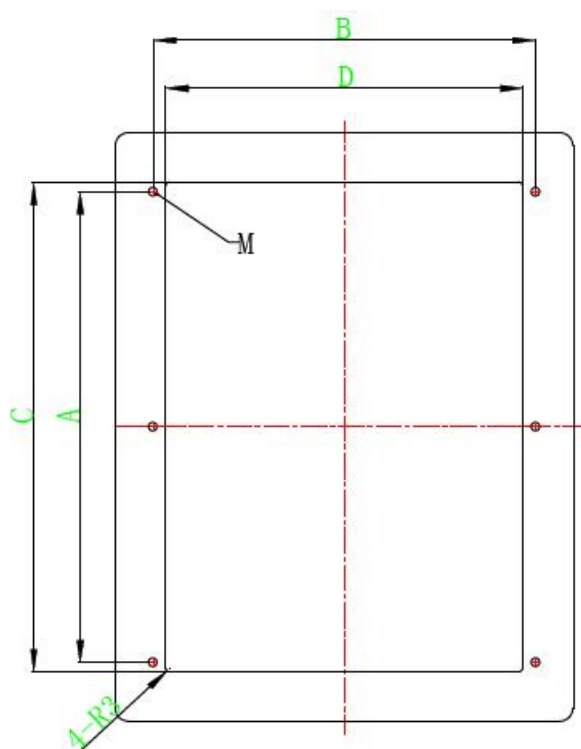

picture 3-7 The size of inlaying board for I4 inverter

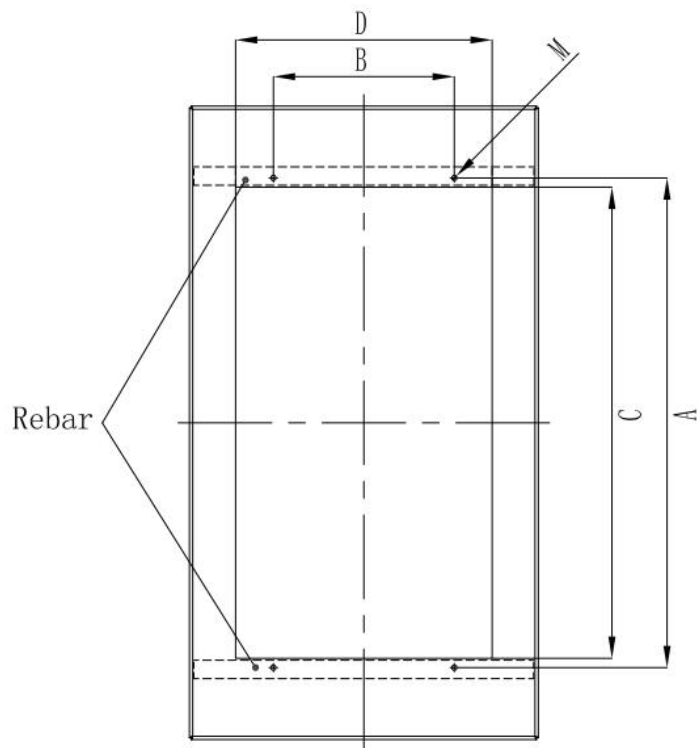

picture 3-8 The size of inlaying board for I5-I6 inverter

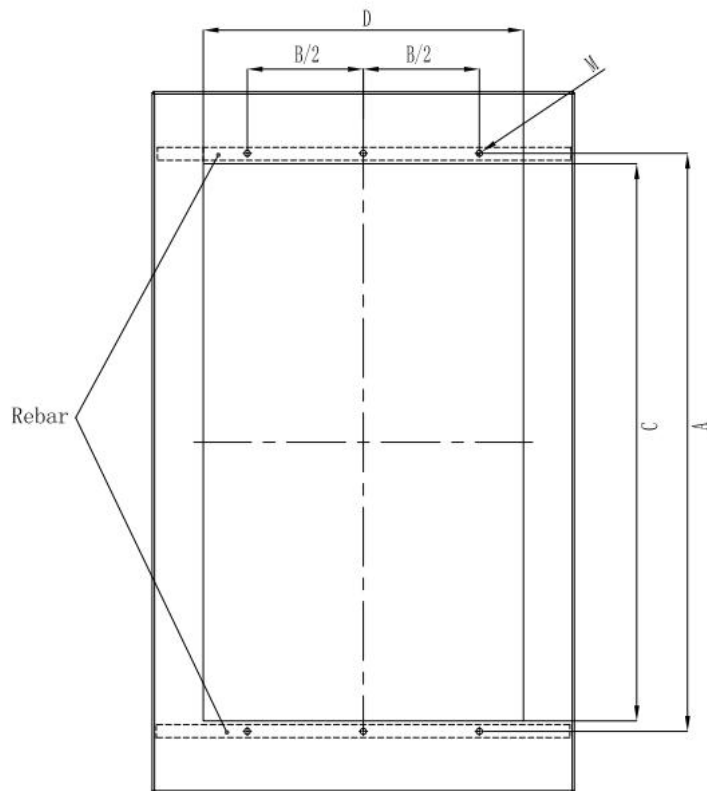

picture 3-9 The size of inlaying board for I7 inverter

The size of inlaying board table

type	install dimensions (Unit: mm)		Hole dimensions (Unit: mm)		Recomm. Install bolt
	A	B	C	D	
I1	248	122	258	136	4-M5
I2	248	122	258	136	4-M5
I3	288	162	298	178	4-M5
I4	355	255	368	273	4-M6
I5	585	275	570	330	4-M6
I6	742	275	715	390	4-M8
I7	900	350	855	480	6-M12
I8	1110	350	1065	490	6-M12

3.2.3 many inverters installed

(1) parallel installation

When several inverter of different sizes are installed in parallel, please align the upper part of inverter and install it again. The minimum gap between inverter is 100mm.

(2) vertical installation

When inverter is installed vertically, the windshield must be added, otherwise the interaction of multiple inverters will cause bad heat dissipation. vertical installation is shown below.

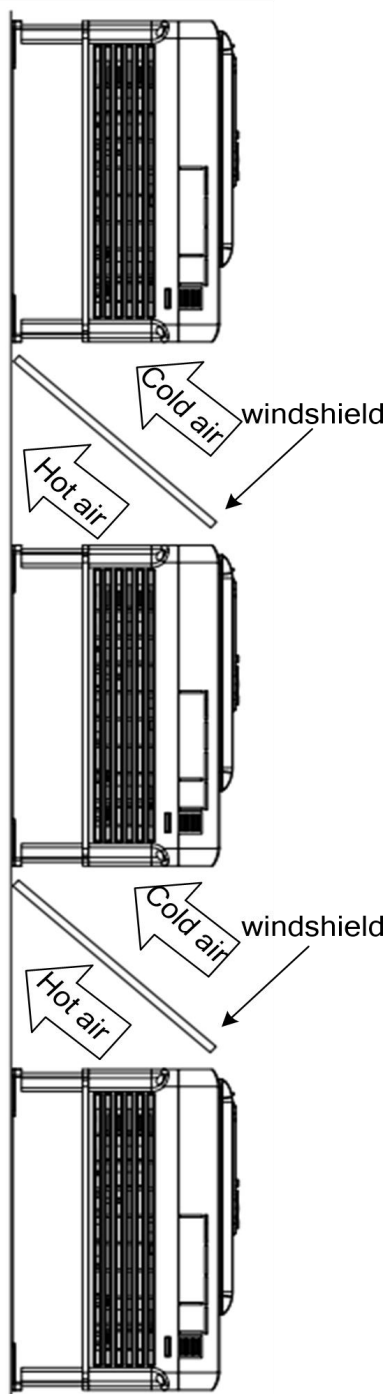

(3) Inclined installation

When many inverters are inclined to install, it is necessary to ensure the separation of the inside duct and outside duct of the inverter, so as to avoid the mutual influence. The inclined installation of multiple inverters is shown below.

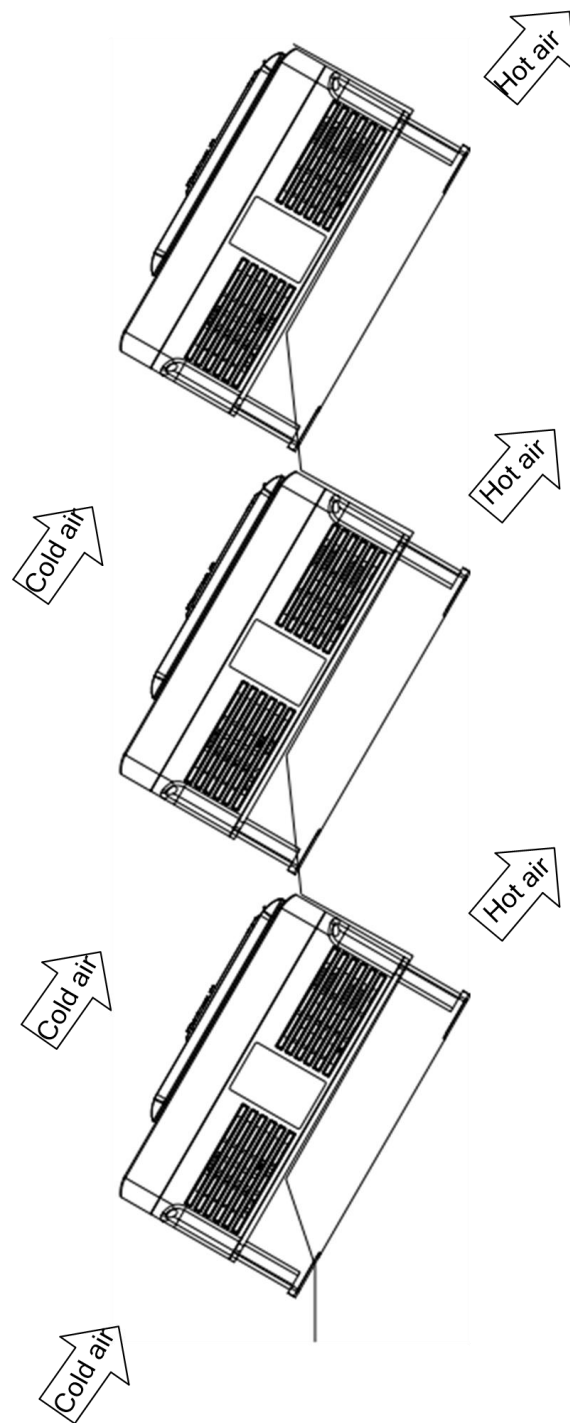

3.3 Detachment and installation of cover plate

Removing steps:

(1) According to the direction arrow 1 indicates, first screw out the positive four cover screws about 5mm.

(2) According to the direction arrow 2 indicates, then slightly move down the cover plate.

(3) According to the direction arrow 3 indicates, and then move the lower cover plate.

To install the cover plate, the procedure is opposite to the above ones.

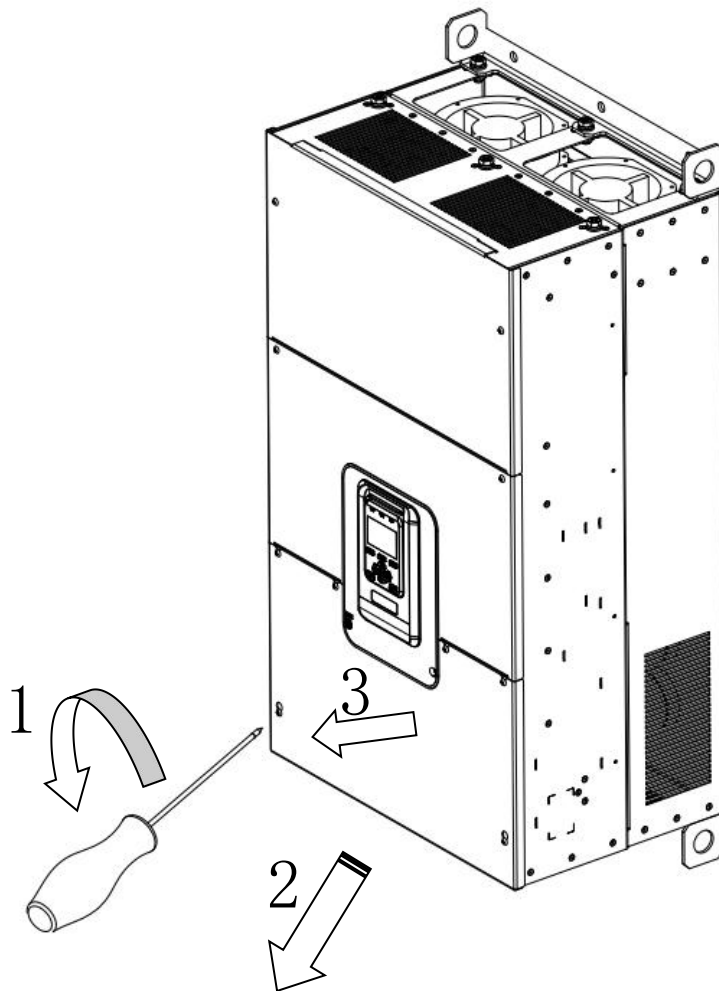
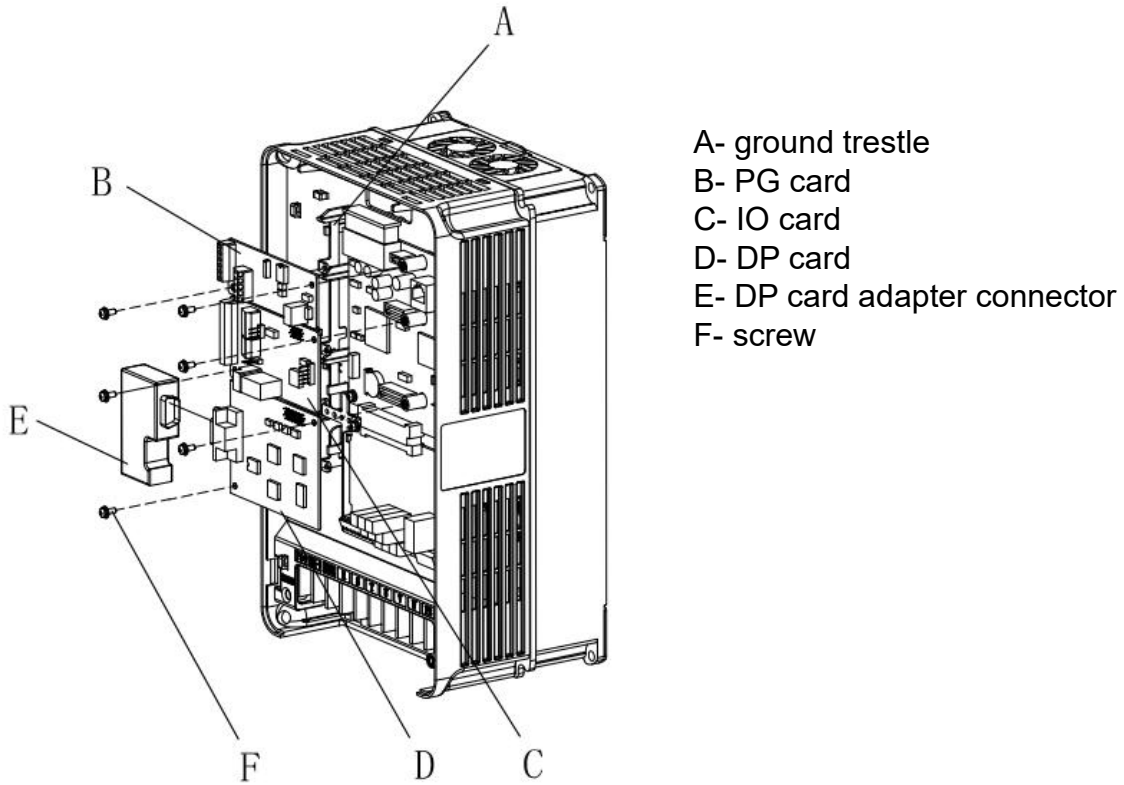

Table 3-10 Dismantle and installation of inverter cover plate

3.4 Installation of adjunct card

The installation of HF630 inverter adjunct card is as follows:



Installation of 30kW and below inverter adjunct card

Installation of DP card connector of 18.5KW and below inverter, please remove the side baffle of inverter. The diagram is shown below:

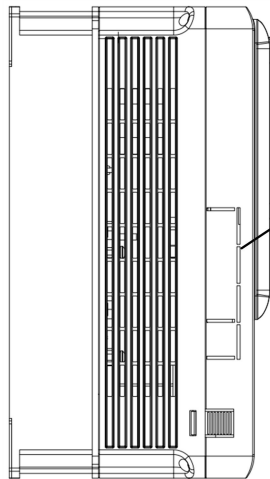

Remove this baffle for easy installation of the DP card connector

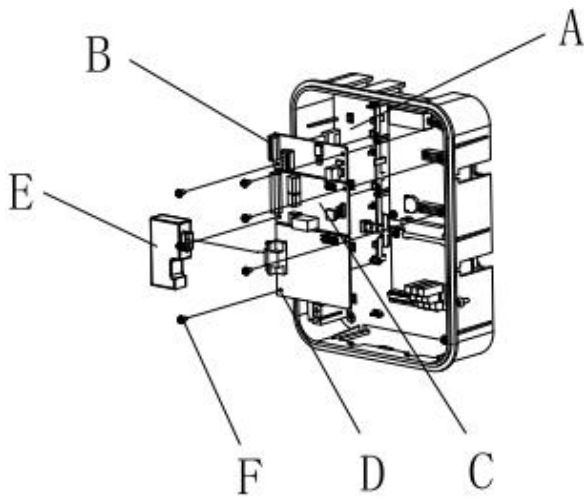

A- ground trestle
 B- PG card
 C- IO card
 D- DP card
 E- DP card adapter connector
 F- screw

Installation of 30kW above inverter adjunct card

3.5 Wiring instruction of PGC2 card

There is a total of 11 user terminals of GDHF-PGC2 general PG card:

A+	A-	B+	B-	Z+	Z-
+15V	GND	AO	GND	BO	

Terminal function description:

description terminal	function	response speed	Voltage range	Output current
+15V, GND	Encoder power supply	...	15V ± 5%	300mA
A+, A- B+, B- Z+, Z-	Encoder signal access	0-80kHz	0-15V	...
AO, GND BO	Digital output	0-50kHz	0-24V	...

Note: PE is shielding wire shielding layer terminals (ground the PE when used).

PGC1 card wiring principle diagram:

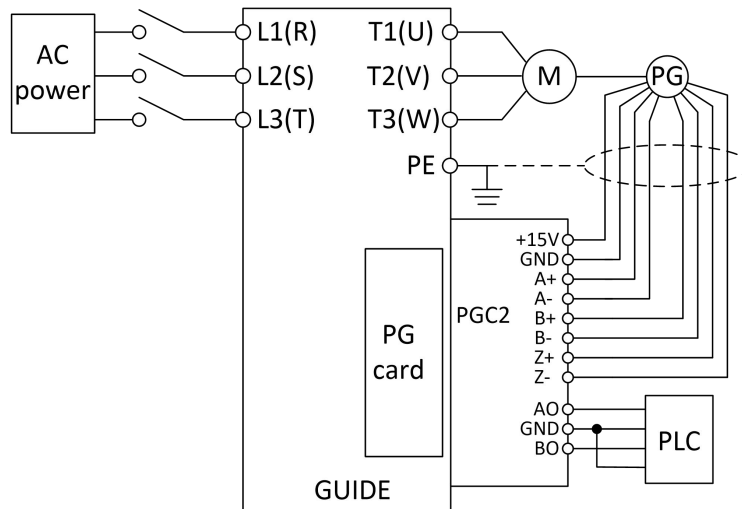

Wiring precautions:

- (1) PG card signal line and the power line should be arranged separately, avoiding parallel lines;
- (2) In order to avoid the encoder signal being interfered, please use shielded cable for the PG card signal line;
- (3) The shielded layer of encoder shielded cable should be connected to the earth (such as the inverter PE terminal), and must be earthed by single end, in order to avoid signal interference;
- (4) No matter single-ended or differential, short circuit is prohibited on PG card A- B-, Z-, GND;
- (5) Guide PGC2 card supports a wide voltage range including 15V long drive

type (RS-422) output encoder.

For field use of encoder, output mode should be firstly determined. Guide PGC2 card supports push-pull, collector open type, voltage type, long drive type (15V) encoder.

(1) Encoder output type: push-pull output

a. Differential connection mode

Connection diagram		Application example	
	Brand	encoder model	
	Gambol	HLE45-1024L-6F. AC	
	P+F	RHI90N-ONAK1R61N-1024	
	ELCO	EC120P45-H6PR-1024	

b. Single-ended connection mode

Connection diagram		Application example	
	Brand	encoder model	
	Gambol	HLE45-600L-3F. AC	
	P+F	RVI78N-10CALA31N-1024	
	ELCO	EC120P45-P6PR-1024	

(2) Encoder output mode: open-collector output

Connection diagram		Application example	
	Brand	encoder model	
	Gambol	HLE45-1024L-30C. AC	
	ELCO	EB38A6-C4PR-1024	

(3) Encoder output mode: voltage output

Connection diagram		Application example	
	Brand	encoder model	
	Gambol	HLE45-600L-3R. AC	
	ELCO	EB50A8-N4PR-1024	

(4) Encoder output mode: long drive output (support 15V voltage)

Connection diagram		Application example	
	Brand	encoder model	
	Gambol	HLE-45-600L-6LY. AC	
	P+F	RHI58N-0BAK1R6XN-1024	
	ELCO	EC120P45-L6TR-1024	

3.6 Wiring instruction of PGD2 card

There is a total of 10 user terminals of GDHF-PGD2 synchronization PG card:

+15V	GND	A1+	A1-	B1+	B1-
		A+	A-	B+	B-

Terminal function description:

description terminal	function	response speed	Voltage range	Output current
+15V, GND	Encoder power supply	...	15V ± 5%	300mA
A+, A- B+, B-	Encoder signal access	0-80kHz	0-15V	...
A1+, A1- B1+, B1-	Encoder signal access	0-50kHz	0-15V	...

Note: PE is shielding wire shielding layer terminals (ground the PE when used).

PGD2 card wiring principle diagram:

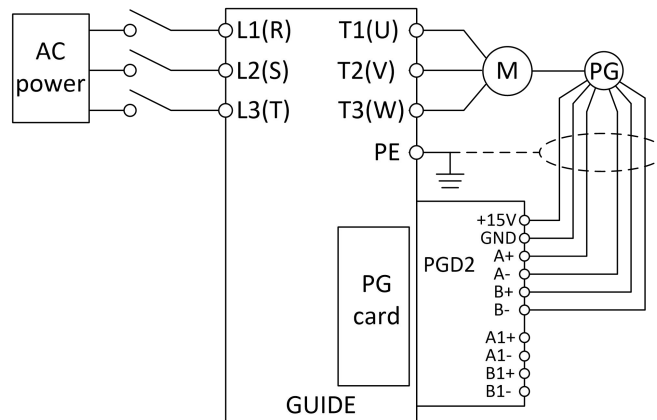

Wiring precautions:

- (1) PG card signal line and the power line should be arranged separately, avoiding parallel lines;
- (2) In order to avoid the encoder signal being interfered, please use shielded cable for the PG card signal line;
- (3) The shielded layer of encoder shielded cable should be connected to the earth (such as the inverter PE terminal), and must be earthed by single end, in order to avoid signal interference;

For field use of encoder, output mode should be firstly determined. Guide PGD2 card supports push-pull, collector open type, voltage type, long drive type (15V) encoder.

- (1) Encoder output type: push-pull output
 - a. Differential connection mode

Connection diagram		Application example	
	Brand	encoder model	
	Gambol	HLE45-1024L-6F. AC	
	P+F	RHI90N-ONAK1R61N-1024	
	ELCO	EC120P45-H6PR-1024	

b. Single-ended connection mode

Connection diagram		Application example	
	Brand	encoder model	
	Gambol	HLE45-600L-3F. AC	
	P+F	RVI78N-10CALA31N-1024	
	ELCO	EC120P45-P6PR-1024	

(2) Encoder output mode: open-collector output

Connection diagram		Application example	
	Brand	encoder model	
	Gambol	HLE45-1024L-30C. AC	
	ELCO	EB38A6-C4PR-1024	

(3) Encoder output mode: voltage output

Connection diagram		Application example	
	Brand	encoder model	
	Gambol	HLE45-600L-3R. AC	
	ELCO	EB50A8-N4PR-1024	

In synchronizing function application, the encoder with differential output signal wiring diagram is as follows:

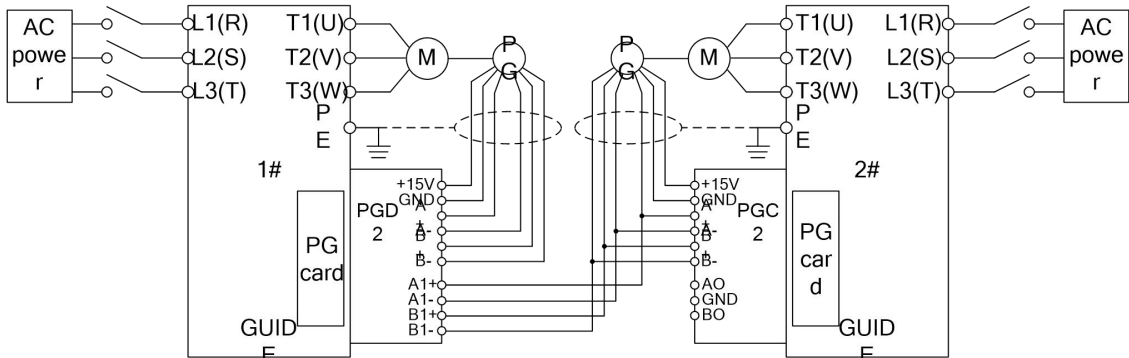

In synchronizing function application, the encoder with single-ended output signal wiring diagram is as follows:

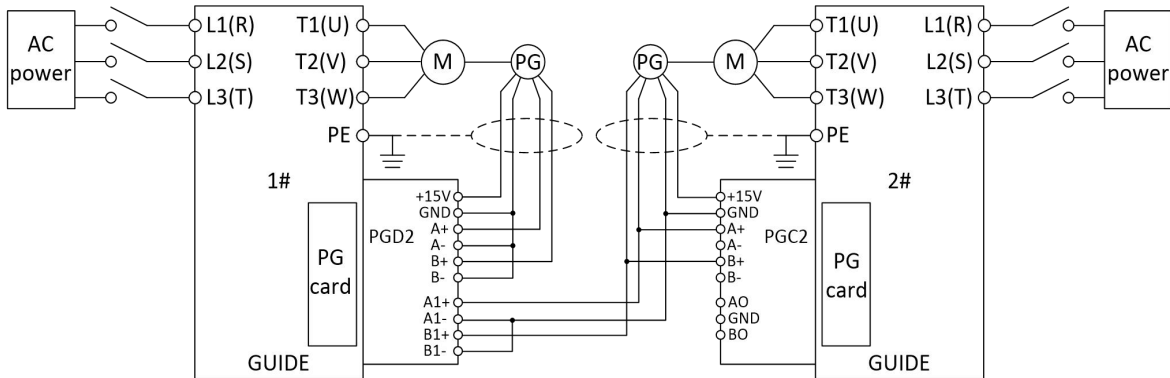

4. Inverter wiring

4.1 Notice on wiring

- (1) The wiring must be carried out by qualified technicians.
- (2) Before wiring, make sure that the power supply has been completely turned off more than 10 minutes; otherwise there is the risk of electric shock.
- (3) It is prohibited to connect the power wire to the inverter output terminals U, V, W.
- (4) The inverter and the motor must be firmly grounded.
- (5) Ensure that there is an intermediate circuit breaker between the inverter and the power supply to avoid accidents to expand in case of inverter failure.
- (6) When a magnetic contactor is installed between the inverter and the motor, the timing of the contactor action should be guaranteed, the contactor can act only when the inverter has no output.
- (7) As shown in Figure 4-1, the inverter U, V, W output terminals can not be added with capacitor absorbing or other RC absorbing device.

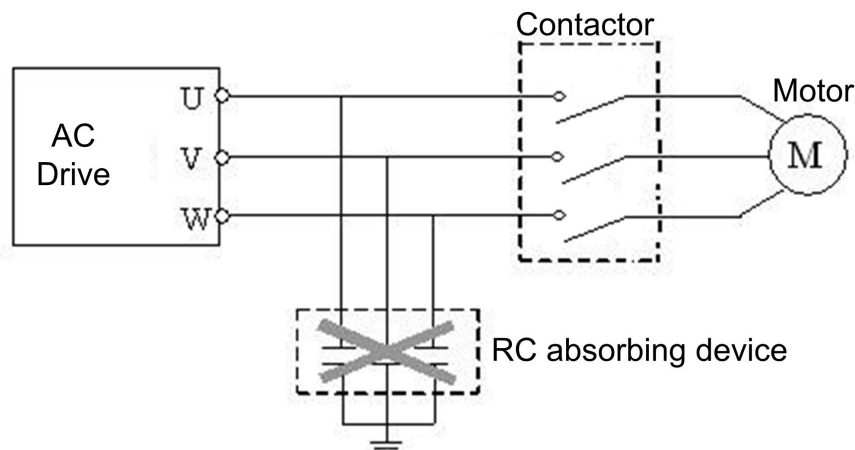

Figure 4-1 Output terminals can not be added with RC absorbing device

- (8) In order to reduce electro magnetic interference, connect surge absorber(s) to coils of magnetic contactor and relays in circuit that around the inverter.
- (9) Use multi-core shielding cable or twisted pair to connect control terminals. Control cables should be 10cm or more away from the main

circuit and high voltage cables (including power cables, motor cables, relays and contactors cables, etc.) during wiring.

- (10) Wiring of relay input and output circuits should use more than 0.75mm² shielding twisted wires or shielding cables. The inverter's ground terminals are connected to the shield ground, the wiring length is less than 50m.
- (11) The control cables should be separated from the main circuit (motive) power cables, and the distance between parallel wiring cables should be more than 10cm, cross-wiring should be vertical.
- (12) Cable length between the inverter and the motor should be less than 100m, when the length is greater than 100m, it is suggested to add output reactor, And consult with the manufacturer.
- (13) All leading wires must be tightened sufficiently to terminals to ensure good contact. Main circuit leading wires should be cable or copper busbar. When using cables, make sure the corresponding cross-section for cold-pressed or firmly welded before implementation of wiring.
- (14) All leading wires withstand voltage levels must match that of the inverter.
- (15) Shielding cable is recommended for output cables (between inverter and motor) longer than 30 m.

4.2 Wiring for main circuit terminals

- (1) I type main circuit terminals

Main circuit terminals of 0.4KW ~ 75KW is shown as below:

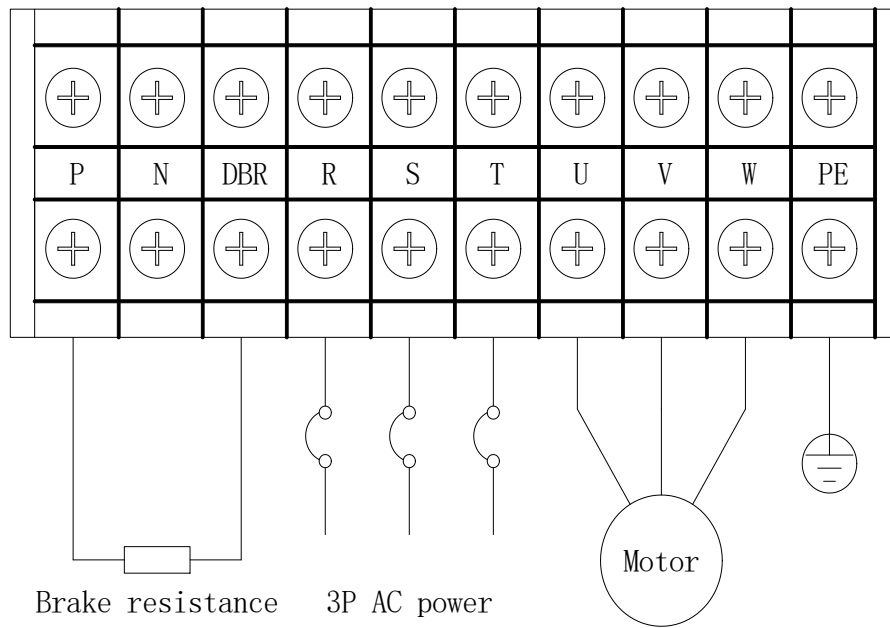

(2) II type main circuit terminals

Main terminals of 90KW ~ 110KW is shown as below:

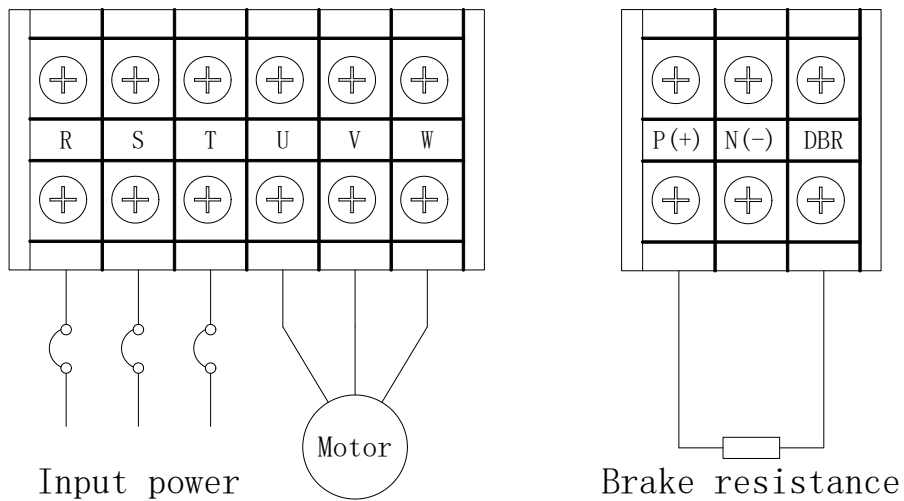

Instructions for main circuit terminal wiring tools:

Type	Power	Screw specifications	Tool	
I1	0.4KW	M4	Cross screwdriver	
	0.75KW			
	1.5KW			
I2	2.2KW			
	3.7KW			
	5.5 KW			
	7.5 KW			
I3	11 KW			M5
	15 KW			
	18.5 KW			
I4	22 KW			M6
	30 KW			
I5	37 KW	M8	Cross screwdriver , double offset ring spanner or socket wrench	
	45 KW			
	55 KW			
I6	75 KW			
	90 KW			
I7	110 KW			M10
	132 KW			
	160 KW			
I8	185 KW			
	220 KW			

Terminal symbol	Function description
P(+)	DC side voltage plus terminals
P1	45KW and above inverter internally installed reactor
N(-)	DC side voltage minus terminals
R、S、T	Connect to power grid 3P AC power
U、V、W	Connect to 3P AC motor

DBR	Brake resistance terminals for inverter of 37KW and below
PE	Inverter grounding terminals or grounding points.

4.3 Control circuit terminals

(1) Control circuit terminals diagram

Terminal No.	1	2	3	4	5	6	7	8
Terminal name	+10V	GND	AI1+	AI1-	AI2+	AI2-	A01	A02
Terminal No.	9	10	11	12	13	14	15	16
Terminal name	DI1	DI2	DI3	DI4	DI5	DI6	DI7	DI8
Terminal No.	17	18	19	20	21	22	23	24
Terminal name	PW	COM	PW	+24V	+24V	D01	+24V	D02
Terminal No.	25	26	27	28	29	30	31	
Terminal name	+24V	D03	D04A	D04C	D04B	D05A	D05C	

(2) Analog output jumper sketch map

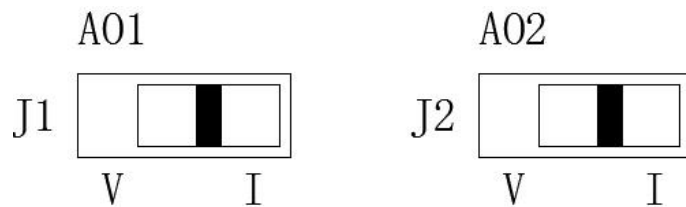

Figure a. Jumper sketch map (current analog output)

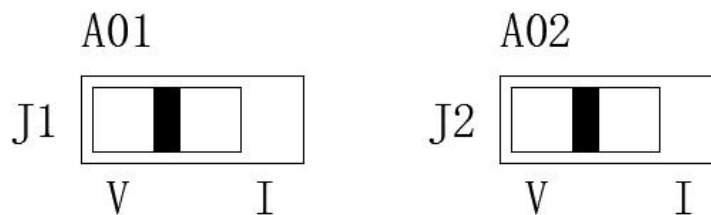

Figure b. Jumper sketch map (voltage analog output)

(3) Control circuit terminals function description

Terminal 1 (+10 V): Analog 10V power output;

Terminal 2 (GND): Analog voltage input negative;

Terminal 3 (AI1 + / AV1): Analog 1 input current positive, with input range of 0/4 ~ 20mA, can also be used as analog 1 voltage input positive,

with input range of $-10 \sim 10V$;

Terminal 4 (AI1-): Analog 1 current input negative;

Terminal 5 (AI2 + / AV2): Analog 2 current input positive with input range of $0/4 \sim 20mA$, can also be used as analog 2 voltage input with input range of $-10 \sim 10V$;

Terminal 6 (AI2-): Analog 2 current input negative;

Terminal 7 (AO1): Analog 1 channel output positive, the output current $0/4 \sim 20mA$ (J9 jumper selects I, Figure a), the output voltage $0 \sim 10V$ (J9 jumper selects V, Figure b);

Terminal 8 (AO2): Analog 2 channel output positive, the output current $0/4 \sim 20mA$ (J10 jumper selects I, Figure a), the output voltage $0 \sim 10V$ (J10 jumper selects V, Figure b);

Terminal 9 (DI1): Digital input 1;

Terminal 10 (DI2): Digital input 2;

Terminal 11 (DI3): Digital input 3;

Terminal 12 (DI4): Digital input 4;

Terminal 13 (DI5): Digital input 5;

Terminal 14 (DI6): Digital input 6;

Terminal 15 (DI7): Digital input 7;

Terminal 16 (DI8): Digital input 8;

Terminal 17 (PW): Digital common end;

Terminal 18 (COM): 24V power end;

Terminal 19 (PW): Digital common end;

Terminal 20 (+24 V): 24V power output;

Terminal 21 (+24 V): 24V power output;

Terminal 22 (DO1): Open collector output 1, DC24V 50mA or less;

Terminal 23 (+24 V): 24V power output;

Terminal 24 (DO2): Open collector output 2, DC24V 50mA or less

Terminal 25 (+24 V): 24V power output;

Terminal 26 (DO3): Open collector output 3, DC24V 50mA or less

Terminal 27 (D04A): Digital output terminal 4 normally opens, relay output;

Terminal 28 (D04C): Digital output terminal 4 common end;

Terminal 29 (D04B): Digital output terminal 4 normally closed, relay output;

Terminal 30 (D05A): Digital output terminal 5 normally opens, relay output;

Terminal 31 (D05C): Digital output terminal 5 common end.

4.4 Basic wiring plan of inverter

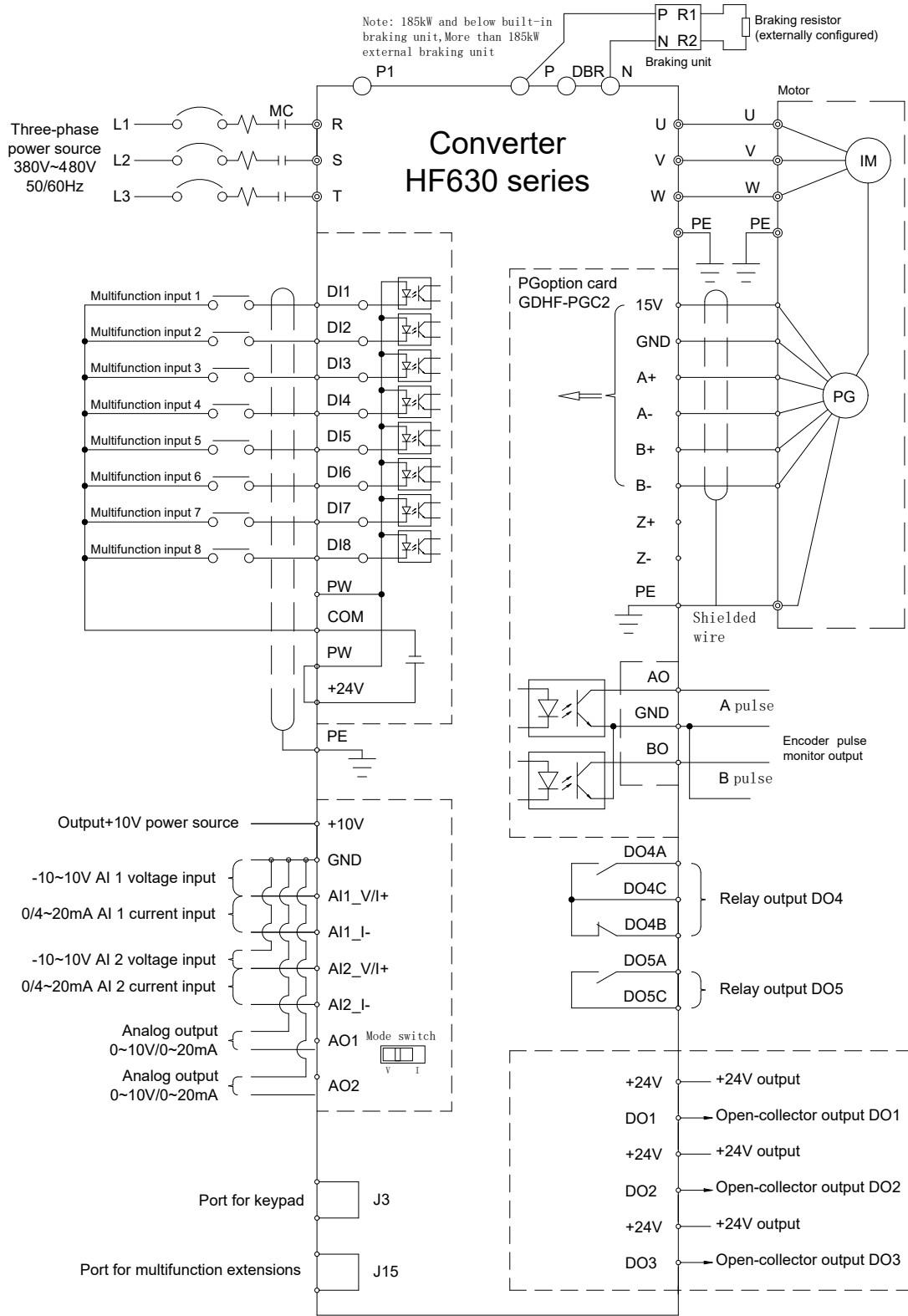

4.5 Input signal wiring plan

Common emitter mode (0V is the common end of the input signal). When the external input signal comes from the NPN transistor, please connect as shown below.

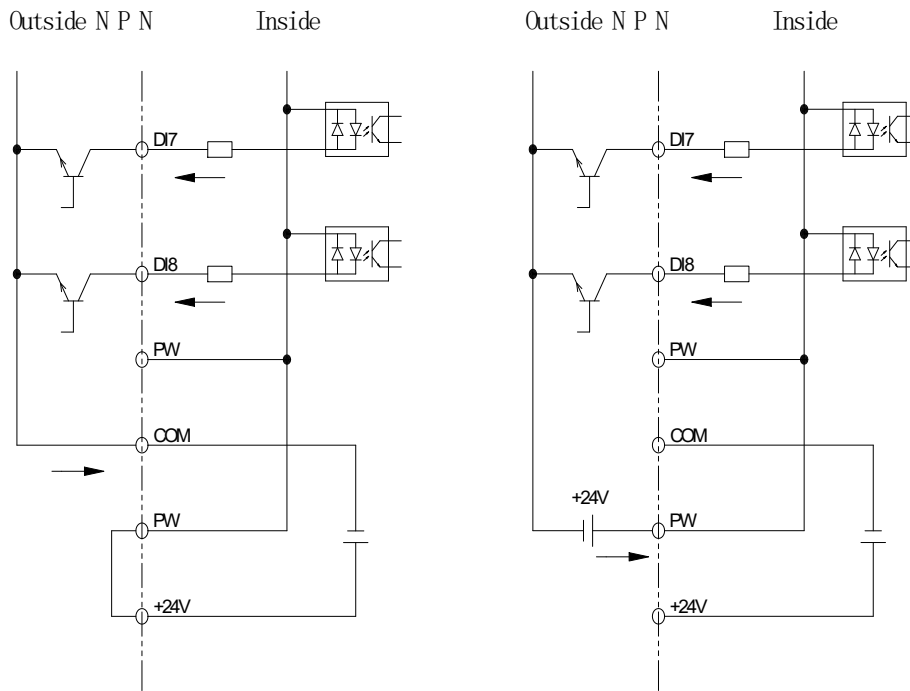

Use the power of inside

Use the power of outside

Common collector mode (+24V is the common end of the input signal). When the external input signal comes from the PNP transistor, please connect as shown below.

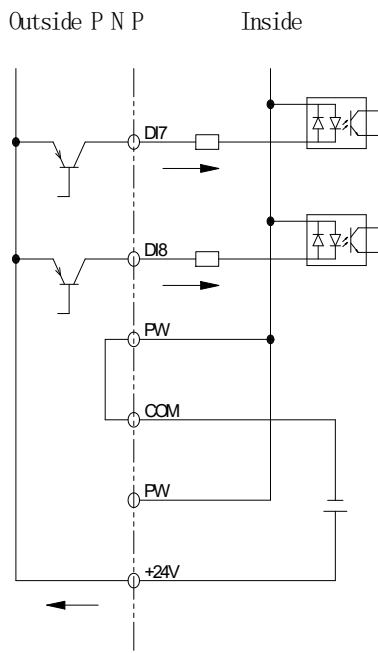

Use the power of inside

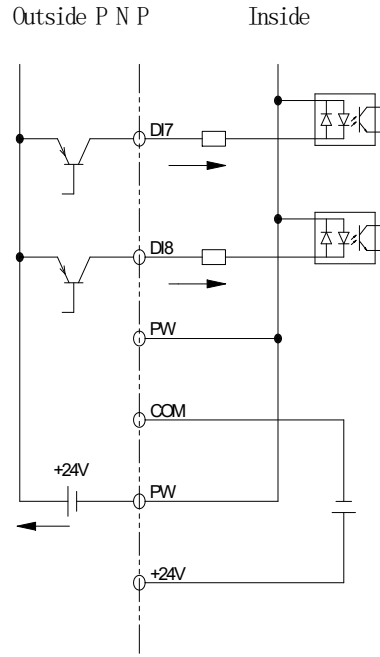

Use the power of outside

4.6 System wiring plan

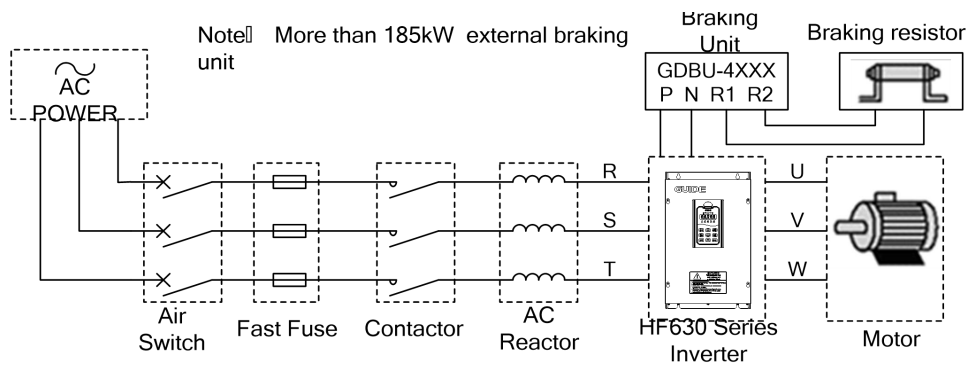

Element name	Description
Power	Please select the input power supply in accordance with the specifications in this instruction manual.
Air switch	<ol style="list-style-type: none"> 1. When the inverter is under repair or not in use for a long time, the air switch can isolate the inverter and the power; 2. When there is a input terminal short circuit or
Contactor	It is convenient to control the inverter power on/off.
Fast fuse	It carries out protection when there is short circuit in the inverter.
AC reactor	<ol style="list-style-type: none"> 1. To improve the power factor; 2. To lower the inverter harmonics to the grid.
Brake resistance	When the motor is in regenerative braking state, it is used to avoid the DC circuit voltage become too high.

4.7 Wiring Specification

Type	Breaker (A)	Input/output cables (copper core cable mm ²)	Contactor rated working current (A)
HF630-0R4-4MT	2.2	2.5	9
HF630-0R7-4MT	4	2.5	9
HF630-1R5-4MT	6	2.5	9
HF630-2R2-4MT	7	2.5	9
HF630-3R7-4MT	12.5	2.5	12
HF630-5R5-4MT	18	2.5	18

HF630-7R5-4MT	22	2.5	18
HF630-011-4MT	29	2.5	25
HF630-015-4MT	39	4	32
HF630-018-4MT	50	6	50
HF630-022-4MT	57	10	50
HF630-030-4MT	80	10	65
HF630-037-4MT	90	16	80
HF630-045-4MT	113	16	95
HF630-055-4MT	138	25	115
HF630-075-4MT	186	35	150
HF630-090-4MT	226	50	205
HF630-110-4MT	258	70	245
HF650-132-4MT	330	95	410
HF650-160-4MT	365	95	410
HF650-185-4MT	438	120	475
HF650-220-4MT	485	150	620

4.8 Input/output AC reactor selection

Type	Capacity	Input reactor 2% input voltage		Output reactor 1% output voltage	
		Current	Inductance	Current	Inductance
HF630-0R4-4MT	0.4 kW	2.2A	6.4 mH	2.2A	3.2mH
HF630-0R7-4MT	0.7 kW	4A	3.5 mH	4A	1.8 mH
HF630-1R5-4MT	1.5 kW	6A	2.4 mH	6A	1.2 mH
HF630-2R2-4MT	2.2 kW	7A	2.0 mH	7A	1.0 mH
HF630-3R7-4MT	3.7 kW	12A	1.1 mH	12A	0.6 mH
HF630-5R5-4MT	5.5kW	19A	743uH	19A	371 uH
HF630-7R5-4MT	7.5kW	22A	644 uH	22A	322 uH
HF630-011-4MT	11kW	28A	493 uH	28A	247 uH
HF630-015-4MT	15kW	38A	368 uH	38A	184 uH

HF630-018-4MT	18.5kW	49A	283 uH	49A	141 uH
HF630-022-4MT	22kW	57A	247 uH	57A	123 uH
HF630-030-4MT	30kW	76A	184 uH	76A	92 uH
HF630-037-4MT	37kW	88A	159 uH	88A	79 uH
HF630-045-4MT	45kW	113A	123 uH	113A	62 uH
HF630-055-4MT	55kW	131A	106 uH	131A	53 uH
HF630-075-4MT	75kW	178A	78 uH	178A	39 uH
HF630-090-4MT	90kW	227A	62 uH	227A	31 uH
HF630-110-4MT	110kW	259A	54 uH	259A	27 uH
HF650-132-4MT	132kW	320A	44 uH	320A	22 uH
HF650-160-4MT	160kW	398A	35 uH	398A	18 uH
HF650-185-4MT	185kW	446A	31 uH	446A	16 uH
HF650-220-4MT	220kW	528A	26 uH	528A	13 uH

4.9 Brake resistance selection

Inverter type	Inverter capacity	Brake resistor			
		recommend value(Ω)	minimum value(Ω)	Power(KW) 30%Kc	Power(KW) 50%Kc
HF630-0R4-4MT	0.4 kW	750	115	≥ 0.2	≥ 0.3
HF630-0R7-4MT	0.7 kW	750	115	≥ 0.2	≥ 0.35
HF630-1R5-4MT	1.5 kW	400	100	≥ 0.5	≥ 0.7
HF630-2R2-4MT	2.2 kW	250	78	≥ 0.8	≥ 1
HF630-3R7-4MT	3.7 kW	100	64	≥ 2.0	≥ 2.5
HF630-5R5-4MT	5.5kW	100	40	≥ 2.0	≥ 2.5
HF630-7R5-4MT	7.5kW	75	40	≥ 3.0	≥ 3.5
HF630-011-4MT	11kW	50	40	≥ 4.0	≥ 5.2
HF630-015-4MT	15kW	40	32	≥ 5	≥ 6.5

HF630-018-4MT	18.5kW	32	24	≥ 6	≥ 8.0
HF630-022-4MT	22kW	24	20	≥ 8	≥ 11
HF630-030-4MT	30kW	22	20	≥ 10	≥ 13
HF630-037-4MT	37kW	21	20	≥ 12	≥ 16
HF630-045-4MT	45kW	13	8	≥ 15	≥ 20
HF630-055-4MT	55kW	10	8	≥ 20	≥ 26
HF630-075-4MT	75kW	7.5	6	≥ 26	≥ 35
HF630-090-4MT	90kW	6.8	3.5	≥ 29	≥ 38
HF630-110-4MT	110kW	5.1	3.5	≥ 38	≥ 50
HF650-132-4MT	132kW	4.2	3.5	≥ 46	≥ 60
HF650-160-4MT	160kW	3.6	2.5	≥ 54	≥ 71

Note: 1、Inverter of 110KW and below have built-in braking units, the corresponding 100% braking torque;

2、Kc: braking rate, the rate of braking process for whole motor working process;

3、Choice of Kc: a、elevator of below 20 floor Kc=10%~20%

b、Trolley、Luffing、Gantry Mechanism Kc=30%

c、Hoisting Mechanism Kc=40%~50%

4、According to the practical application, the brake resistor power may be appropriately enlarged.

4.10 Installation instructions conform to EMC requirements

(1) EMC common knowledge

EMC (electromagnetic compatibility) is an abbreviation which refers to the ability of the equipment or system that can work properly in its electromagnetic environment without cause unstandable electromagnetic disturbance to anything in that environment. EMC includes two aspects: electromagnetic interference and electromagnetic immunity.

Electromagnetic interference can be divided into two categories according to the transmission route: Conducted interference and radiated interference.

Conducted interference is the interference that transmits along the conductor, all conductors, such as wires, conduction, transmission wires, inductors and capacitors, etc, all of them are the transmission channel of conducted

interference.

Radiated interference is the interference that transmits in the form of electromagnetic wave, whose energy is inversely proportional to the square of the transmission distance.

EMI (electromagnetic interference) must have three conditions or essentials: the interference source, transmission channel and sensitive receivers, all three are indispensable. EMC problems can be mainly solved from these three aspects. For the user, the equipment itself as an interference source or receiver is unavoidable, so to solve the EMC problems is mainly from the transmission channel.

Different electrical and electronic equipment, due to their different EMC standards or levels, their EMC abilities are also various.

(2) Inverter EMC characteristics

Same as other electrical and electronic devices, the inverter is a source of electromagnetic interference and at the same time also an electromagnetic receiver in a control system. Working principle of the inverter determines that it would produce a certain degree of electromagnetic interference noise. In order to ensure its reliable operation, a certain resistance to electromagnetic interference in an electromagnetic environment should be considered during its design state. When the inverter system is working, its EMC characteristics mainly presents in the following aspects:

- a. Generally the input current is non-sinusoidal that contains a lot of high-order harmonic waves which forms the external electromagnetic interference that will lower the power factor of grid and increase line losses.
- b. The output voltage is high frequency PWM wave, it causes the motor elevated temperature, thus reduces motor life; it also increases the leakage current, so cause line leakage protection device malfunction and generates strong electromagnetic interference, which influences the reliability of other electrical equipment in the same system.
- c. As an electromagnetic receiver, its powerful interference will trigger malfunction or even damage to the inverter which finally affect the normal use of the user.
- d. In the system wiring, the inverter's own interference on its ambient

environment supplements its own anti-interference characteristics. The procedure of reducing its own interference is also the procedure of increasing its anti-interference characteristics at the same time.

(3) EMC installation guidance

To ensure the electrical equipment in the same system work reliably with consideration of the inverter EMC characteristics, this chapter introduces EMC installation methods with details from the aspects of noise suppression, field wiring, grounding, leakage current and power filters for on-site installation reference. Only when these five aspects are achieved, EMC will achieve good results.

a. Noise suppression

All inverter control terminals are connected with shielding cables, which grounded the shielding layer to the nearest point at the inverter entrance. The cable clips constitute a 360-degree looping grounding. It is prohibited to twist the shielding layer as braid before grounded with the inverter; this will greatly reduce the shielding effect or even lost shielding effect.

Cables between inverter and motor (motor line) adopt shielded cables or independent cable trunk, motor lines' shielded layer or one side of the metal casing of cable trunk are grounded with the inverter to the nearest point, while the other side connected to the motor housing. Installation of a noise filter can greatly suppress electromagnetic interference.

b. On-site wiring

Electric power wiring: in different control systems, the power inlet cable is powered independently from the power transformer, generally it adopts four-core cables, where three of which is live wire, and one is ground wire.

Equipment category: generally there are different electrical devices in a same control cabinet, such as inverter, filter, PLC and instrumentation, etc. Their different ability of electromagnetic noise emission and electromagnetic noise withstand require the classification of these devices. The devices can be classified into strong noise devices and sensitive noise devices; the same class devices can be installed in the same area. The distance between different types of devices should be more than 20cm.

c. Grounding

During operation the inverter must be safely and reliably grounded, the impedance of the grounding conductor must be lower than $0.1\ \Omega$. Grounding is not only to guarantee the equipment and personal safety, but also the simplest way to solve EMC problems most effectively with lowest cost, which should be given priority. Grounding has three categories: special grounding pole, common grounding pole and grounded electrode cascade. Special pole grounding should be used in different control systems, common pole grounding should be used for different devices in a same control system, and grounded electrode cascade should be used for different devices that in the same power supply line.

d. Leakage current

Leakage current includes leakage current between lines and earth leakage current. The cover leakage current must be lower than 3.5mA , and the control terminals leakage current must be lower than 0.25mA . Its size is determined by the size of distributed capacitor during system wiring and the inverter's carrier frequency. Earth leakage current is the leakage current that flowing through the common grounded electrode, which flows into not only the inverter system but also into other equipment. The leakage current may cause malfunction of leakage circuit breakers, relays, or other devices. Leakage current between lines is the leakage current that flowing through the distributed capacitor of the inverter input and output side. The size of the leakage current is determined by the inverter carrier frequency, motor cable length, and cable cross-sectional area. The higher the carrier frequency, the longer the motor cable, the larger cable cross-sectional area, the greater the leakage current is.

Solutions:

Reduce the carrier frequency can effectively reduce the leakage current. When the motor wire is comparatively long (50m or more), AC reactors should be installed in the inverter output side, when the motor wire is even longer, one reactor should be installed at every certain distance.

e. Noise filter

The noise filter can play a good role in the electromagnetic decoupling, even in the case of working conditions are met, it is recommended to install one by the user.

In fact, there are two kinds of noise filters:

1. Noise filter installed at the input side of the inverter: It is used to isolate the inverter from the other equipment.
2. Noise filter or isolation transformer installed at the input side of the other equipment: it is used to isolate the other equipment from the inverter

5. Operation instructions

5.1 Operation panel instruction

HF630 series inverter's operation keyboard (also known as operator) is shown as below. It contains F1 key, F2 key, RUN key, STOP key, UP / DOWN key, LOCAL / REMOTE key, arrow keys, LEFT/ RESET key and RIGHT/ENTER key, the user can use these keys to set the parameters of the inverter, monitor the running status, control the motor running and stop and so on.

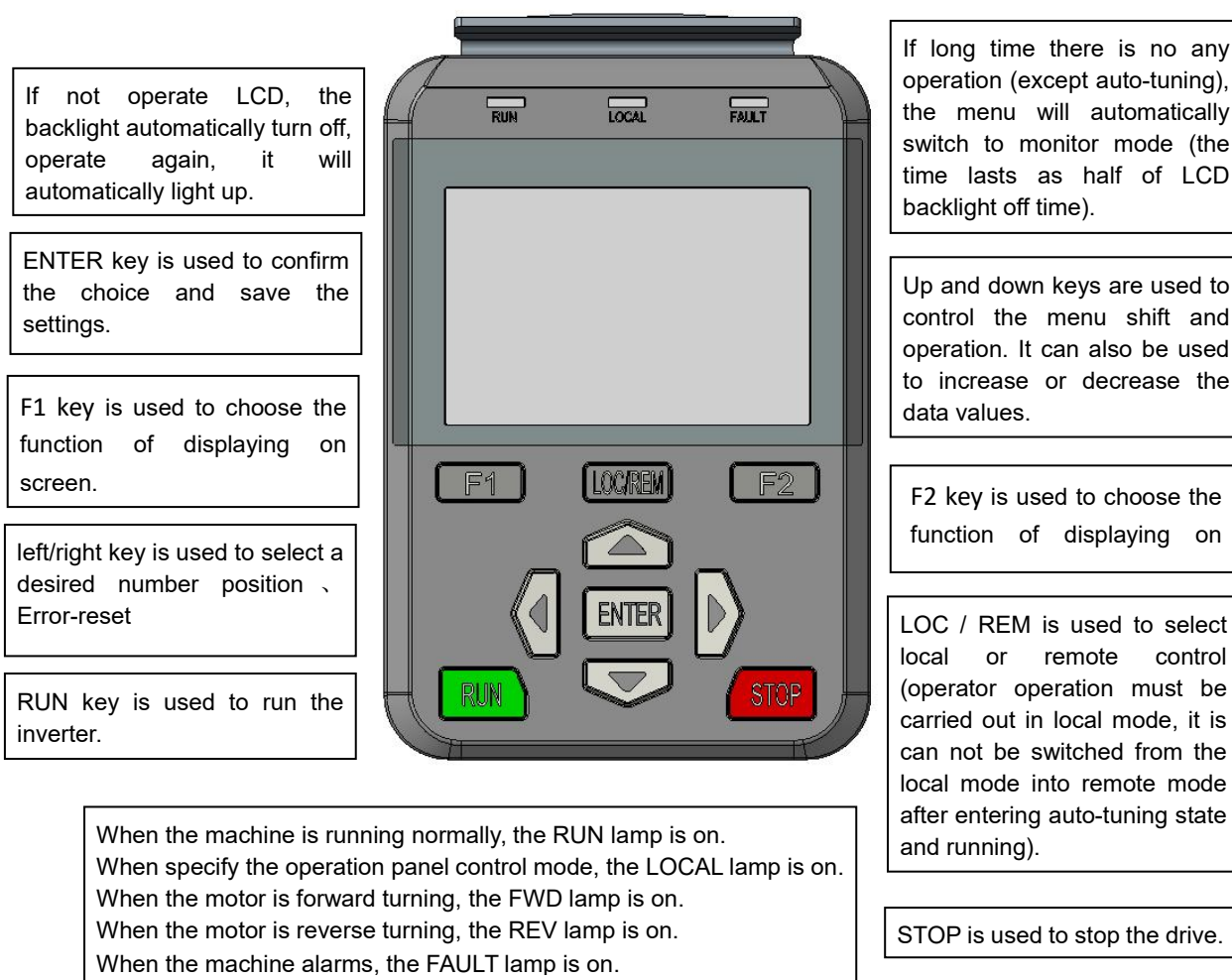

5.2 Access Permissions

The operation panel has two access restriction levels:L1 and L2.When the operation panel leaves the factory,the L1 password and L2 password are not set,the function setting menu and the parameter setting menu are not restricted. If the parameter initialization function is used, the L1 password and L2 password will be restored to the unset state.In the main menu, you can set or modify the L1 and L2 password.When the L1 password is set,the L1 access restriction enabled.When the L2 password is set,the L2 access restriction enabled;

The access restriction levels is showed below table:

Unset L1 and L2 password	Access is not restricted
Set L1 or L2 password	The function setting menu is restricted; The parameter setting menu is restricted;
Entering the correct L1 password	The function setting menu is not restricted; The parameter setting menu is not restricted; The P16 parameter setting menu is not restricted;
Entering the correct L2 password	The function setting menu is not restricted; The parameter setting menu is not restricted; The all parameter setting menu is not restricted;

5.3 Key operation

The key data value is composed of the main menu and the lower menu. If moved from the upper menu to the lower menu, press ▼key. If moved from lower menu back to the upper menu, press ▲key. You can also increase or decrease the values by the up and down keys. Press ENTER key to confirm a determined data value. Use ◀▶key when select a desired number position during setting parameters: When the cursor is moved to the far left, it will automatically jump back to the far right. When using the keyboard to run the inverter, press RUN and STOP keys to start and stop the motor (please first finish setting parameters and shift into local mode), and press LOCAL / REMOTE key to switch between local and remote modes.

5.4 Main menu configuration diagram



The main interface contains status bar, monitoring interface, menu and three functions.

The status bar shows the direction of motor, the speed of motor, the output current, Warning|Error.

	Description
Direction of motor	FWD: forward direction REV: reverse direction
Speed of motor	Output frequency, Unit:Hz
Output current	The output current of inverter, Unit: A
warning error	Without warning and error: N N With warning: W With error: E With warning or error, the letter will blink
Speed	Output speed ,Unit: RPM
TCC_DI8-1	Digit input From left to right is DI8 to DI1.
DO	Digit output From left to right is DO8 to DO1.

The monitoring interface: one page shows three monitoring parameter, and choose the monitoring parameter by pressing up-down key.

menu :displaying the function of F1 key and F2 key,include "option", "menu", "esc", "enter".

On the main interface, pressing ENTER key, you can quickly enter the given speed interface, and setting the given speed quickly.

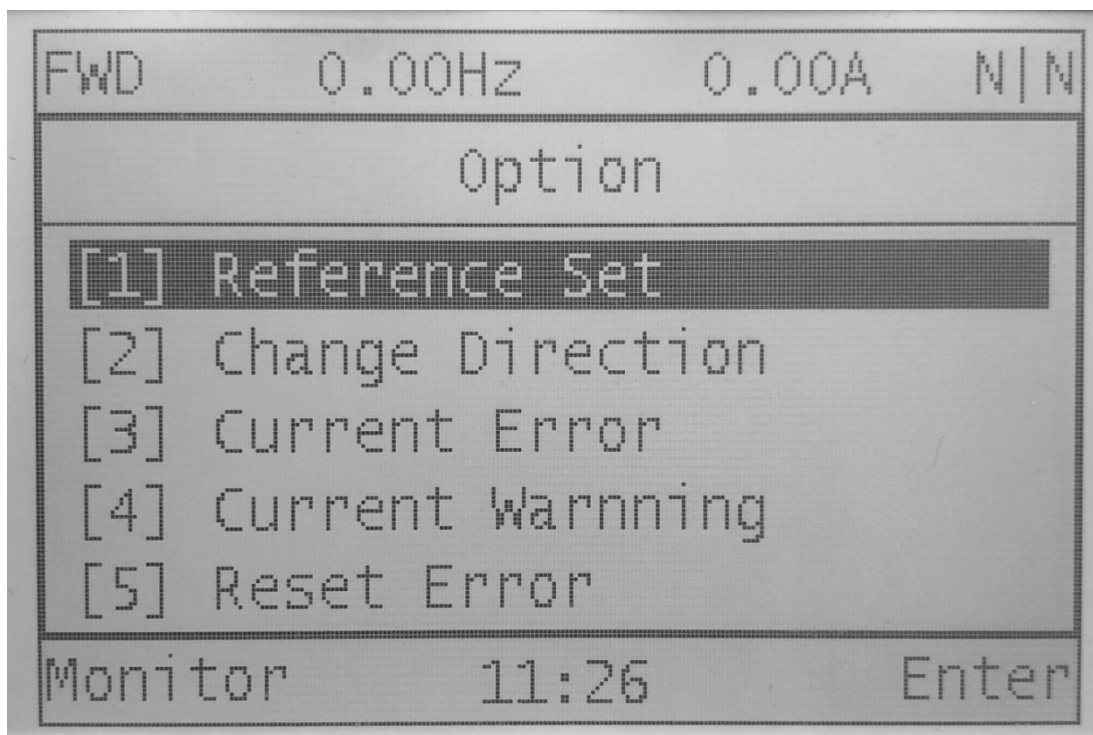

Pressing the option to enter the picture shown above. The submenu of option is shown below table.

Option		
Number of submenu	Submenu	Description
1	Reference Set	The given speed, torque, torque limit and so on
2	Change Direction	Change the direction of motor when in local mode
3	Current Error	Display the current error and description of the current error
4	Current Warning	Display the current warning and description of the current warning
5	Reset Error	Resetting the current error, setting the errorcode to zero
6	Monitor Setting	Setting the parameter of monitor interface

7	Firmware Version	Displaying the software version of control board and operation
8	Menu Language	choosing the language of menu

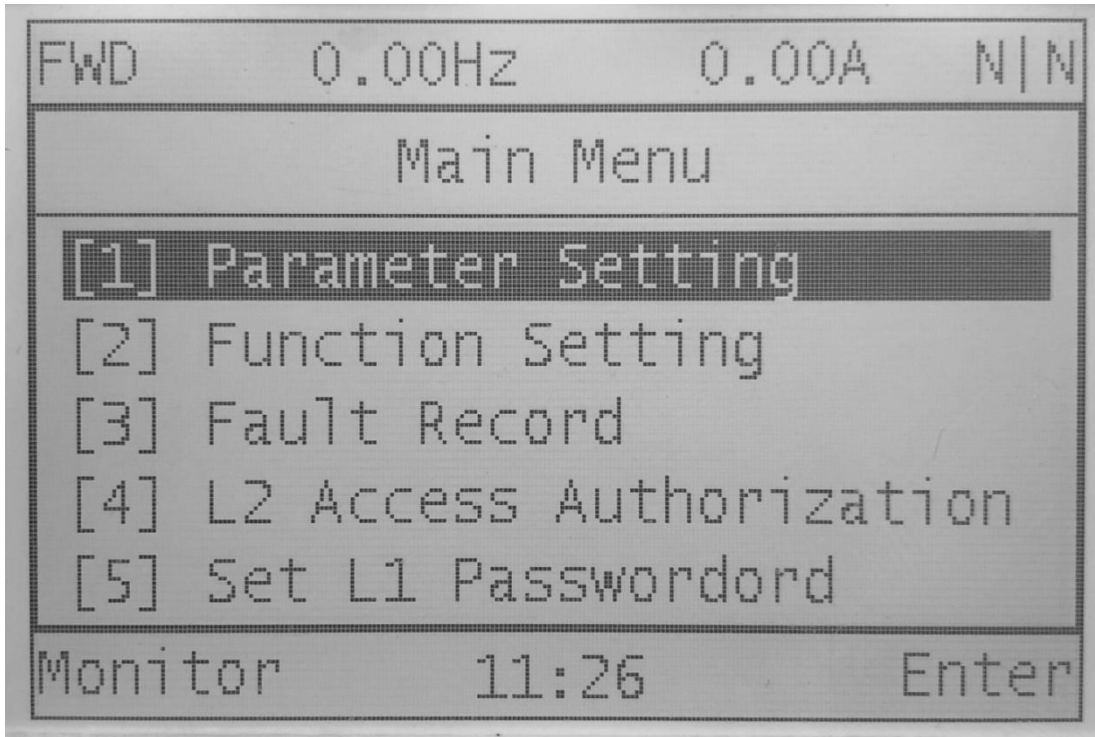

Pressing the menu to enter the picture shown above. The submenu of menu is shown below table.

Main menu		
Number of submenu	Submenu	Description
1	Parameter Setting	Setting the parameter of inverter. If the L1 or L2 password has been set, the parameter setting menu is restricted. According to the screen prompt, after entering the correct password, you can enter the menu.

2	Function Setting	Be enable the function. If the L1 or L2 password has be set, the function setting menu is restricted. According to the screen prompt, after entering the correct password, you can enter the menu.
3	Fault Record	Displaying the error record, and the description of error.
4	L2 Access Authorization	Entering the correct L2 password, the all parameters setting are not restricted, the all functions setting are not restricted.
5	Set L1 Password	Set or modify L1 password
6	Set L2 Password	Set or modify L2 password
7	Display Setting	Setting the date, time, light of operation

5.5 《option》 Menu configuration description

(1) Reference Set

Mode category	Category	Unit	description
Reference Set	Speed set	[Hz]	
		[%]	100% is the rated speed of motor
	Torque set	[%]	100% is the rated torque of motor
	Torque limit set	[%]	100% is the rated torque of motor
	A01 set	[%]	100% is the voltage 10V or current 20mA
	A02 set	[%]	100% is the voltage 10V or current 20mA

(2) Change Direction

Changing the direction of motor.

(3) Current Error

Display the current error and description of the current error.

(4) Current Warning

Display the current warning and description of the current warning.

(5) Reset Error

Resetting the current error, setting the error code to zero.

(6) Monitor Setting

Setting the parameter of monitor interface.

(7) Firmware Version

Displaying the software version of control board and operation.

(8) Menu Language

Choosing the language of menu, Chinese or English.

5.6 《menu》 Menu configuration description

(1) Parameter Setting

Setting the parameter of inverter.

If the L1 or L2 password has been set, the parameter setting menu is restricted.

According to the screen prompt, after entering the correct password, you can enter

the menu.

(2) Function Setting

If the L1 or L2 password has been set, the function setting menu is restricted.

According to the screen prompt, after entering the correct password, you can enter the menu.

Function Setting		
Mode type	Category	Function description
1	MotoTuning I	Motor static auto-tuning
2	MotoTuning II	Motor dynamic auto-tuning
3	MotoTuning III	Mechanical moment of inertia auto-tuning
4	DC-Link Tuning	It is effective only in AFE control mode.
5	Shortcut Paras Setting	Fast setting on common use parameters
6	Parameter Initialization	Parameters are initialized as original ones.
7	Delete Fault Records	Fault clearance mark
8	System Restart	Inverter system reset, which equals to re-energization.
9	Backup Parameter	Back-up all present parameters.

10	Recover Parameter	Back to the backup parameters.
11	Compare Parameter	Compare the existing and backup parameters and list out the modified parameters (In case the backup parameters are initialized factory setting values, only the modified parameter values will be listed out).

Parameter backup can be used to back up all the existing parameters of the inverter (including auto-tuning parameters), this feature is used to restore the backup values to the same type of inverter. *Note: Do not switch off the power or disconnect operator during operation!*

Parameter restore can be used to restore the backup parameters, and it is not limited to the same backup inverter, as long as the version is matched. If failures occur, please check whether the version is consistent with correct backup.

Note: Please operate this function after machine stops and don't switch off the power or disconnect operator during operation! It will cause the inverter reset!

Parameter comparison: if the parameters have been successfully backed up this feature can be used to view the modified parameters by pressing the ▼, ▲ keys to display all parameters, press "Enter" to enter for modifying parameters.

Note: The first step of this function will check all the parameters and compare with the backup values, please do not switch off the power or disconnect the communication!

(3) Fault Record

Displaying the error record, and the description of error.

(4) L2 Access Authorization

Entering the correct L2 password, the all parameters setting are not restricted, the all functions setting are not restricted.

(5) Set L1 Password

Set or modify L1 password. L1 level access is restricted.

(6) Set L2 Password

Set or modify L2 password. L2 level access is restricted.

(7) Display Setting

Display setting is used to change the menu language, monitor channel settings, set the LCD contrast settings of the inverter.

6. Inverter test run

6.1 Inverter test run sequence

Please perform test run based on the following flow.

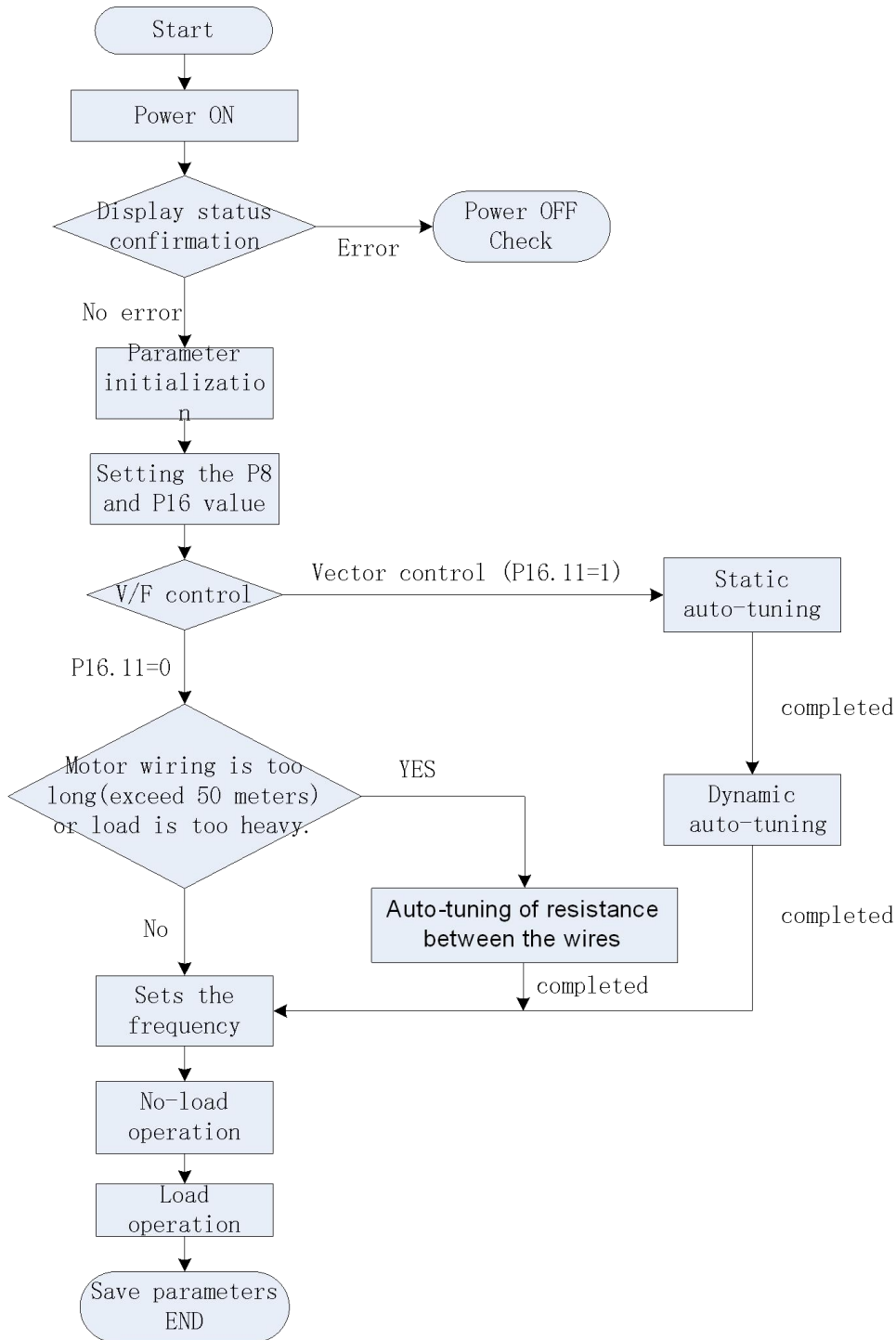

Test run flow chart

Note:

Before perform auto-tuning by operator, make sure to select local from “local / remote” key.

The initial value of the control mode is V / F control (P16.11 = 0). To get better control performance, it is recommended V / F control to perform static auto-tuning.

Vector control is divided into closed loop vector control (P16.11 = 2) and the open-loop vector control (P16.11 = 1). After finishing static and dynamic auto-tuning in open-loop vector control mode, if the control mode has shifted into closed loop vector control, then it is no need to redo auto-tuning, in which state it can be directly operated after checking the encoder connection and settings.

6.2 Inverter test run operation

6.2.1 Energization

Before turning on the power, please confirm the following items:

- (1) Whether the power supply voltage is correct?
3P AC380-480V 50/60Hz
- (2) Whether the motor output terminals (U, V, W) are acutally connected with the motor?
- (3) Whether the inverter control terminals are acutally connected with wires of other control devices?
- (4) Whether the wires are connected during using the PG encoder card?
- (5) Whether the motor is in no-load state (without connecting to mechanics)?

6.2.2 Display status confirmation

When the power is on, the normal display of the keyboard is shown as below:

FWD	0.00HZ	0.00A	N N
Motor speed[Hz] :	0.00Hz		
Frequency[Hz]:	10.00Hz		
Bus voltage :	560.60V		
Option	11:45	Menu	

When a failure occurs, the display is different from above. Below is an example when an undervoltage fault occurs:

FWD	0.00Hz	0.00A	N E
E105 Under Voltage			
Quit	11:45	RST	Er

6.2.3 Parameter initialization

Parameter values are restored to their default values after parameter initialization, the specific instructions, see Chapter 5.4 function settings.

6.2.4 Parameter setting

Parameter setting is used to inveter tet run.

Function code	Name	Description	Setting values
P8.0	RUN_SRC	[0] Terminal (DI) [1] Local Operator [2] Profibus DP [3] MODBUS [4] FREE BLOCK	1
P8.3	STOP mode	[0] Ramp STOP [1] Free Running STOP	1
P8.10	Speed_Input Source	[0] I/O TERMINAL [1] AI 1 [2] AI 2 [3] LOCAL OPERATOR	3

		[4] Profibus DP [5] MODBUS [6] FREE BLOCK	
P8.16	Accel 1 @time	Sets the time to accelerate from 0 to the P8.15.	3
P8.35	Decel 1 @time	Sets the time to decelerate from P8.34 to the 0.	3
P16.0	Supply Voltage	380V	
P16.2	Nominal Power	Refer to motor nameplate	
P16.3	Nominal Voltage	Refer to motor nameplate	
P16.4	Nominal Current	Refer to motor nameplate	
P16.5	Nominal Frequency	Refer to motor nameplate	
P16.6	Nominal Speed	Refer to motor nameplate	
P16.7	Number of Poles	Refer to rated revolution setting, quote the integer of the following calculation result: (120XP16.5/P16.6)	
P16.9	Reference Speed	Set based on rated revolution (120XP16.5/P16.7)	
P16.11	Control Mode Selection	[0] V/F [1] S/L Vector Control [2] CL Vector Control Set based on requirement	
P16.14	V/F Curve Pattern	[0] Linear Curve V/F [1] Multi-point Curve V/F [2] Square Curve V/F	0
P16.24	Max. Frequency	Sets the maximum frequency (valid only when running in V/F control mode).	50Hz
P7.0	Current Limit for motor 1	0~300[%]	180%
P7.4	Over Current Trip for motor 1	0~300[%]	235%
P7.19	Over Speed Trip [M1]	100.0~720.0[%]	120%

6.2.5 Motor parameter auto-tuning

It is necessary to perform auto-tuning mode when the motor cable is too long and in the vector control. Please follow the steps below to perform auto-tuning to automatically identify motor parameters.

(1) Select the control mode

Setting P16.11 value, it is vector control if select [1] or [2], which demands static and dynamic auto-tuning. It is V / F control if select [0], which demands only static auto-tuning.

(2) Static auto-tuning

Static auto-tuning in the V / F control mode can also be called as auto-tuning of resistance between the lines, in which the inverter recognizes only the stator resistance values; under static auto-tuning in the vector mode the inverter recognizes the stator and rotor resistance and inductance parameters.

Select static auto-tuning in “Function setting” and press “ENTER” to perform auto-tuning. It displays “Static auto-tuning is in progress” and “Auto-tuning finished” respectively during and after the procedure.

(3) Dynamic auto-tuning

Under dynamic auto-tuning in vector mode, the dynamic auto-tuning optimized parameters identify the parameter values. Before a dynamic auto-tuning starts, static auto-tuning in vector mode must be completed.

Select dynamic auto-tuning in “Function setting” and press “ENTER” to perform auto-tuning. It displays “Dynamic auto-tuning is in progress” and “Auto-tuning finished” respectively during and after the procedure.

(4) Optimization auto-tuning

After the completion of the dynamic auto-tuning in vector mode, and with motor shafted, it is possible to perform optimization auto-tuning. The motor load can not exceed 50% of the rated load during optimization auto-tuning, which only optimizes the mechanical inertia. After the completion of the dynamic auto-tuning, the mechanical inertia uses the default values , then the vector control can operate normally. If for better control performance, then it is suggested to carry out optimization auto-tuning.

6.2.6 Notice before auto-tuning mode

Inverter HF630 series offer parameter auto-tuning function. Correct settings of motor nameplate parameters guarantees accurate parameters auto-tuning. In order to ensure the control performance, please select motors according to the inverter application standards. If the gap between motor power and inverter application standards is too large, the inverter control performance will be

significantly decreased.

Please confirm the following four items before the motor auto-tuning begins:

Check items	Notice
Whether the motor shaft is connected to other mechanical equipment?	Motor will rotate 7.5% of rated speed in dynamic auto-tuning. If the motor is connected to other machinery and equipment, make sure that the load does not exceed 50% of rated load. In the no-load condition, the dynamic auto-tuning can get more accurate results, if the load exceeds 50% of rated load, the dynamic auto-tuning may not be successful.
Whether the motor capacity and the inverter capacity is very different?	When the motor power is much smaller than the inverter power, it may not complete the auto-tuning normally. (the motor power should not be smaller than 1/5 that of the corresponding inverter.)
Whether the input motor parameters are correct?	Whether parameters of group P16 are consistent with the motor nameplate parameters, such as rated power, voltage, current, speed, number of poles, and synchronous speed. A mistake input could lead to failure of the auto-tuning or motor abnormal run.
Whether there are encoders installed on motors?	There should be encoders if it adopts closed-loop vector control. If it adopts V/F control or open-loop vector control, it won't be any influence if with or without encoders.

6.2.7 No-load operation test run

The instructions for motor no-load test run are described as below.

It is necessary to confirm safety around motor and mechanical equipment before run the test, to ensure whether the emergency stop circuits and mechanical safety devices are able to operate correctly. Confirm whether the motor rotation is normal (whether there is abnormal sound and vibration) and check whether the motor acceleration and deceleration is normal.

- (1) Turn on the power. The initial screen displays;
- (2) Press the “LOC / REM” key to select LOCAL, the LOCAL indication light is on;
- (3) Press the “ENTER” key to set the parameter set[1]: given frequency. Press

the "RUN" key of the operator to run the inverter, the "RUN" indication light is on, and the motor turns forward. (It is suggested the given frequency is 5Hz)

- (4) Check that the motor rotation is in the correct direction and the inverter is without fault;
- (5) If there is no fault in step 4, then increase the frequency command value. Please confirm its responsiveness while changing in each time with 50Hz increments. During each increase of a setting value, please confirm the output current through the operator to ensure that current does not exceed the rated motor current.
- (6) After the confirmation is completed, press the "STOP" key to stop the run.

6.2.8 Test run with load connected

The method of motor test run with load connected will be described below.

Following attentions should be paid when connecting to mechanical system:

- (1) Ensure the safety around electrical equipment and machinery;
- (2) Ensure that the motor stops completely;
- (3) Connect the motor to the mechanical system;
- (4) Confirm whether the mounted screws are tight, and the motor shaft and the mechanical systems are securely fixed;
- (5) Confirm whether the emergency stop circuit and mechanical side safety device can act correctly;
- (6) To prevent malfunction, please be ready at any time to press the "STOP" key.

Please confirm the following items during running:

- (1) Whether the mechanical action is in the correct direction (whether the direction of motor rotation is correct);
- (2) Whether the acceleration and deceleration of the motor is normal.

After connecting the motor to the mechanical system, perform test run with load by using the same steps as with no-load operation.

- (1) Confirm whether the output current is too large;
- (2) Change the frequency command and rotation direction to confirm whether there is abnormal noise and vibration.

6.2.9 Parameter save

Select the “parameter backup” in “Function Setting”, and copy the inverter parameter values to the memory zone of the operator. In case of replacement of the main control board due to inverter failure, just copy the data that recorded in the operator to a new control board, then the operation can be restored. (The software version must be consistent with the previous one in the control board when restoring parameters; otherwise it is unable to successfully restore parameters).

7. Inverter parameter setting instruction

7.1 Initializing parameter control P0

Par. NO	Parameter Name	Description	Range	Default	Ref. Chapter
P0.0	Ini-OPTION	[0]DEFAULT SET [1]LATEST SAVE	0~1	0	
P0.1	Initialize POWER	The power of inverter	0~25	14	
P0.3	Initialize FREQ	[0] 50Hz [1] 60Hz	0~1	0	
P0.4	Password	The password for initializing parameter			

7.2 Parallel inverter and panel observation configuration P2

Par. NO	Parameter Name	Description	Range	Default	Ref. Chapter
P2.0	Parallel Inverter Mode	[0] STAND ALONE: used as a single inverter; [1] MASTER: used as the master inverter of parallel. [2] SLAVE: used as the slave inverter of parallel.	0~2	0	See 8.1
P2.1	Motor switch setting	Selects motor switch source [0]Digital input: switched by terminal control; [1]Profibus DP: switched by communication control.	0~1	0	
P2.2	LANGUAGE	[0] CHINESE [1] ENGLISH	0~1	0	
P2.3	Number of Parallel Slave	Sets the number of parallel slave.	0~5	1	
P2.33	LCD Back Light Time	Set the time of LCD back light	1~100min	10	

7.3 Digital input set of terminals P3

Par. NO	Parameter Name	Description	Range	Default	Ref. Chapter
P3.0	DI1	Multifunctional input terminal	0~32	1	
P3.1	DI2	Multifunctional input terminal	0~32	2	
P3.2	DI3	Multifunctional input terminal	0~32	5	
P3.3	DI4	Multifunctional input terminal	0~32	6	
P3.4	DI5	Multifunctional input terminal	0~32	7	
P3.5	DI6	Multifunctional input terminal	0~32	8	
P3.6	DI7	Multifunctional input terminal	0~32	0	
P3.7	DI8	Multifunctional input terminal	0~32	0	
P3.12	Power-on auto run control	[0]prohibit; [1]enable	0~1	0	

Functions of DI terminals:

Value	Function	Description
0	DISABLED	Set 0 for reserved terminals to avoid malfunction.
1	RUN	The terminal is used to control forward or reverse RUN of the AC inverter.
2	RUN @REVERSE	
3	INVERTER ENABLE (High level valid)	The terminal is valid when being connected with COM.
4	INVERTER ENABLE @NC (Low level valid)	The terminal is valid when being disconnected from COM.
5	FAULT RESET	The terminal is used for fault reset function, the same as the function of </RST key on the operator. Remote fault reset is implemented by this function.
6	M_STEP1 (Bit 0)	Multiple steps instruct input terminal (see 8.2)
7	M_STEP2 (Bit 1)	
8	M_STEP3 (Bit 2)	
9	M_STEP4 (Bit 3)	
10	Hook mode	The function is available when the terminal becomes ON. (see8.10)
11	DIRECTION SWITCH	The terminal is used to change the moving direction when the terminal becomes ON.
12	REMOTE_EMERGENCY	It is valid when input terminal is high level.

	(High level valid)	
13	LOCAL_EMERGENCY @NC (Low level valid)	It is valid when input terminal is low level.
14	REMOTE_EMERGENCY (High level valid)	It is valid when input terminal is high level.
15	REMOTE_EMERGENCY @NC (Low level valid)	It is valid when input terminal is low level.
16	PARLLEL_MODE SLAVE_RDY	If the slave is ready for RUN, the terminal becomes ON.
17	MOTOR_SEL [bit0]	Motor selection bit1 and motor selection bit2 combine to motor selection signals, of which 00 indicates the target motor 1, 01 indicates the target motor 2, 10 indicates the target motor 3 and 11 indicates the target motor 4.
18	MOTOR_SEL [bit1]	
19	AFE DIODE ONLY	When this terminal becomes ON ,the IGBT cannot work when in AFE control mode.
20	LINE_SW_STATUS	Perform main contactor pull confirmation when in AFE control mode.
21	FUNC 21	Reserved
22	BRAKE_SW_STATUS	(See 8.2)
23	ANIT Grab Open	(see 8.10)
24	FREE_RUN STOP	The function is available when the terminal becomes ON.
25	FUNC 25	Reserved
26	TRQ_DYN_CTRL	When this terminal becomes ON, it runs in the torque control mode, otherwise it runs in the speed control mode.
27	FUNC 27	Reserved
28	TORQUE_ZERO	When this terminal becomes ON, the torque setting is zero.
29~64	FUNC 29~ FUNC 64	Reserved

7.4 Digital Output set of terminals P4

Par. NO	Parameter Name	Description	Range	Default	Ref. Chapter
P4.0	DO1	Multifunctional output terminal	0~64	0	
P4.1	DO2	Multifunctional output terminal	0~64	0	

P4.2	D03	Multifunctional output terminal	0~64	0	
P4.3	D04	Multifunctional output terminal	0~64	0	
P4.4	D05	Multifunctional output terminal	0~64	0	
P4.16	DO_FREE_BLOCK1	The setting of free function block	0~500	0	
P4.17	DO_FREE_BLOCK2	The setting of free function block	0~500	0	
P4.18	DO_FREE_BLOCK3	The setting of free function block	0~500	0	
P4.19	DO_FREE_BLOCK4	The setting of free function block	0~500	0	

Multi-function switch output terminal functions as follows:

Value	Function	Description
0	DISABLED	The terminal has no function.
1	RUN	When the AC inverter is running, the terminal becomes ON. (see 8.3)
2	FAULT	When the AC inverter stops due to a fault, the terminal becomes ON.
3	MOTOR BRAKE	When the motor brake release conditions are met, the terminal becomes ON. (see 8.3)
4	RUN @REQUEST	When the run command has been entered, the terminal becomes ON.
5	INVERTER READY	If the AC inverter is ready for RUN, the terminal becomes ON.
6	M_STEP0	[6]~[9]When the multi-speed command has been entered, the terminal becomes ON.
7	M_STEP1	
8	M_STEP2	
9	M_STEP3	
10	FUNC 10	Reserved
11	DIRECTION	When the direction command has been entered, the terminal becomes ON.
12	WARNING	If a fault occurs on the AC inverter, the terminal becomes ON.
13	WARNING @OT	If the motor overheat fault occurs on the AC inverter, the terminal becomes ON.
14	WARNING @OL	If the motor overload fault occurs on the AC inverter, the terminal becomes ON.

15	WARNING @OS	If the motor overspeed fault occurs on the AC inverter, the terminal becomes ON.
16	FUNC_16	Reserved
17	MOTION CTRL 0	When motor 1 control mode has been selected, the terminal becomes ON.
18	MOTION CTRL 1	When motor 2 control mode has been selected, the terminal becomes ON.
19	MOTION CTRL 2	When motor 3 control mode has been selected, the terminal becomes ON.
20	MOTION CTRL 3	When motor 4 control mode has been selected, the terminal becomes ON.
21	FUNC_21	Reserved
22	LOW SPEED	When the inverter output frequency is less than the speed limit, the terminal becomes ON.
23	HIGH SPEED	When the inverter output frequency is less than the speed limit, the terminal becomes ON.
24~31	FUNC_24~FUNC_31	Reserved
32	SOFT_CHARGING	For AFE control mode.
33~48	FUNC_33~FUNC_48	Reserved
49	PROFIBUS FUNCTION 1	The status of this terminal is determined by the profibus function 1.
50	PROFIBUS FUNCTION 2	The status of this terminal is determined by the profibus function 2.
51	PROFIBUS FUNCTION 3	The status of this terminal is determined by the profibus function 3.
52	PROFIBUS FUNCTION 4	The status of this terminal is determined by the profibus function 4.
53	PROFIBUS FUNCTION 5	The status of this terminal is determined by the profibus function 5.
54~56	FUNC_54~FUNC_56	Reserved
57	LOCAL FUNCTION 1	
58	LOCAL FUNCTION 2	
59	LOCAL FUNCTION 3	
60	LOCAL FUNCTION 4	
61	FREE BLOCK 1	The status of this terminal is determined by the free function block 1.
62	FREE BLOCK 2	The status of this terminal is determined by the free function block 2.
63	FREE BLOCK 3	The status of this terminal is determined by the free function block 3.

64	FREE BLOCK 4	The status of this terminal is determined by the free function block 4.
----	--------------	---

7.5 Analog input set of terminals P5

Par. NO	Parameter Name	Description	Range	Default	Ref. Chapte
P5.0	AI1 @TYPE	[0] AI Disabled [1]0~+10V [2]-10~+10V [3]0~20mA	0~3	1	
P5.1	AI1@Filtering Time	Sets the filter time constant for AI1. The value becomes more stable the longer the time programmed, but it becomes less responsive to rapidly changing analog signals.	0.0~1000.0 [ms]	25.0 [ms]	
P5.2	AI1@OFFSET_V	The voltage offset of AI1.	-10.00~10.00 [V]	0.000 [V]	See 8.4
P5.3	AI1 @OFFSET_I	The current offset of AI1.	-20.00~20.00 [mA]	0.000 [mA]	See 8.4
P5.4	AI1@MIN_V	The minimum voltage of AI1.	-10.00~10.00 [V]	0.000 [V]	See 8.4
P5.5	AI1@MIN_I	The minimum current of AI1.	0.00~20.00 [mA]	0.000 [mA]	See 8.4
P5.6	AI1@MIN	The minimum setting value of AI1.	-300.0~300.0 [%]	0.0 [%]	See 8.4
P5.7	AI1@MAX_V	The maximum voltage of AI1.	-10.00~10.00 [V]	10.000 [V]	See 8.4
P5.8	AI1@MAX_I	The maximum current of AI1.	0.00~20.00 [mA]	20.000 [mA]	See 8.4
P5.9	AI1@MAX	The maximum setting value of AI1.	-300.0~300.0 [%]	100.0 [%]	See 8.4
P5.18	AI2@TYPE	[0] AI Disabled [1]0~+10V [2]-10~+10V [3]0~20mA	0~3	3	

P5.19	AI2@Filtering Time	Sets the filter time constant for AI2. The value becomes more stable the longer the time programmed, but it becomes less responsive to rapidly changing analog signals.	0.0~1000.0 [ms]	25.0 [ms]	
P5.20	AI2@OFFSET_V	The voltage offset of AI2.	-10.00~10.00 [V]	0.000 [V]	
P5.21	AI2 @OFFSET_I	The current offset of AI2.	-20.00~20.00 [mA]	0.000 [mA]	
P5.22	AI2@MIN_V	The minimum voltage of AI2.	-10.00~10.00 [V]	0.000 [V]	
P5.23	AI2@MIN_I	The minimum current of AI2.	0.00~20.00 [mA]	0.000 [mA]	
P5.24	AI2@MIN	The minimum setting value of AI2.	-300.0~300.0 [%]	0.0 [%]	
P5.25	AI2@MAX_V	The maximum voltage of AI2.	-10.00~10.00 [V]	10.000 [V]	
P5.26	AI2@MAX_I	The maximum current of AI2.	0.00~20.00 [mA]	20.000 [mA]	
P5.27	AI2@MAX	The maximum setting value of AI2.	-300.0~300.0 [%]	100.0 [%]	

7.6 Analog output set of terminals P6

Par. NO	Parameter Name	Description	Range	Default	Ref. Chapter
P6.0	A01 @Output	See Table 7.1	0~14	2	
P6.1	A01 @FREE_BLOCK	The analog output of free function block.	0~1000	0	See 8.5
P6.2	A01 @Minimum	The minimum output value of A01.	-300.0~ 300.0 [%]	0.0 [%]	See 8.5
P6.3	A01 @Maximum	The maximum output value of A01.	-300.0~ 300.0 [%]	100.0 [%]	See 8.5

P6.4	A01 @Min_Out [mA, V]	The minimum output voltage/current signal of A01.	0.0~100.0 [%]	0.0 [%]	See 8.5
P6.5	A01 @Max_Out [mA, V]	The maximum output voltage/current signal of A01.	0.0~100.0 [%]	100.0 [%]	See 8.5
P6.6	A01 @Offset Adj.	The adjust offset of A01.	-100.00~ 100.00 [%]	0.00 [%]	
P6.7	A01 @Fixed Output	Sets the fixed output of A01. (When P6.0 set to [13], this value is valid.)	0.0~100.0 [%]	0.0 [%]	
P6.8	A01 Filter Time	Sets the filter time constant for A01. The value becomes more stable the longer the time programmed, but it becomes less responsive to rapidly changing analog signals.	0.0~1000.0 [ms]	10.0 [ms]	
P6.14	A02 @Output	See table 7.1	0~14	4	
P6.15	A02 @FREE_BLOCK	The analog output of free function block.	0~1000	0	
P6.16	A02 @Minimum	The minimum output value of A02.	-300.0~ 300.0 [%]	0.0 [%]	
P6.17	A02 @Maximum	The maximum output value of A02.	-300.0~ 300.0 [%]	100.0 [%]	
P6.18	A02 @Min_Out [mA, V]	The minimum output voltage/current signal of A02.	0.0~100.0 [%]	0.0 [%]	
P6.19	A02 @Max_Out [mA, V]	The maximum output voltage/current signal of A02.	0.0~100.0 [%]	100.0 [%]	
P6.20	A02 @Offset Adj.	The adjust offset of A02.	-100.00~ 100.00 [%]	0.00 [%]	
P6.21	A02 @Fixed Output	Sets the fixed output of A02. (When P6.14 set to [13], this value is valid.)	0.0~100.0 [%]	0.0 [%]	
P6.22	A02 Filter Time	Sets the filter time constant for A02. The value becomes more stable the longer the time programmed, but it becomes less responsive to rapidly changing	0.0~1000.0 [ms]	10.0 [ms]	

		analog signals.			
--	--	-----------------	--	--	--

Table 7.1: Description of A0

Value	Function	Description
0	Frequency	Inverter output frequency (unsigned)
1	Frequency 2	Inverter output frequency (signed)
2	Motor Speed	Motor speed (unsigned)
3	Motor Speed 2	Motor speed (signed)
4	Output Current	Output Current
5	Motor Torque	Motor Torque (unsigned)
6	Motor Torque 2	Motor Torque (signed)
7	Motor Load	Motor Load
8	DC-link Voltage	DC-link Voltage (%)
9	Output Power	Output Power
10	Output Voltage	Output Voltage
11	Temperature	The temperature of the inverter (The output value is a percentage relative to the maximum temperature 150°C)
12	PROFIBUS Set	Determined by Profibus
13	Fixed Output	Determined by P6.7 or P6.21.
14	Local Set	Determined by the monitoring software.

7.7 Protection setting P7

Par.NO	Parameter Name	Description	Range	Default	Ref. Chapter
P7.0	Current Limit	Sets the current limit for motor 1.	0.0~300.0 [%]	180.0 [%]	See 8.6
P7.1	Current Limit [M2]	Sets the current limit for motor 2.	0.0~300.0 [%]	180.0 [%]	See 8.6
P7.2	Current Limit [M3]	Sets the current limit for motor 3.	0.0~300.0 [%]	180.0 [%]	See 8.6
P7.3	Current Limit [M4]	Sets the current limit for motor 4.	0.0~300.0 [%]	180.0 [%]	See 8.6
P7.4	Over Current Trip	Sets the over current trip for motor 1.	0.0~300.0 [%]	235.0 [%]	See 8.6
P7.5	Over Current Trip	Sets the over current trip	0.0~300.0	235.0	See 8.6

	[M2]	for motor 2.	[%]	[%]	
P7.6	Over Current Trip [M3]	Sets the over current trip for motor 3.	0.0~300.0 [%]	235.0 [%]	See 8.6
P7.7	Over Current Trip [M4]	Sets the over current trip for motor 4.	0.0~300.0 [%]	235.0 [%]	See 8.6
P7.8	Zero-Sequence Current Trip	Sets the zero-sequence current trip for motor 1.	0.0~100.0 [%]	20.0 [%]	See 8.6
P7.9	Zero-Sequence Current Trip [M2]	Sets the zero-sequence current trip for motor 2.	0.0~100.0 [%]	20.0 [%]	See 8.6
P7.10	Zero-Sequence Current Trip [M3]	Sets the zero-sequence current trip for motor 3.	0.0~100.0 [%]	20.0 [%]	See 8.6
P7.11	Zero-Sequence Current Trip [M4]	Sets the zero-sequence current trip for motor 4.	0.0~100.0 [%]	20.0 [%]	See 8.6
P7.12	Over Link-Voltage Trip	Sets the over link-voltage trip.	600~820 [V]	800 [V]	See 8.6
P7.13	Under Link-Voltage Trip	Sets the under link-voltage trip.	300~500 [V]	350 [V]	See 8.6
P7.14	Over-Temperature Trip	Sets the over-temperature Trip.	60.0~100.0 [°C]	87.5 [°C]	See 8.6
P7.15	Over-Temperature Warning	Sets the over-temperature warning.	50.0~100.0 [°C]	80.0 [°C]	See 8.6
P7.19	Over Speed Trip [M1]	Sets the over speed trip for motor 1.	100.0~720.0 [%]	120.0 [%]	See 8.6
P7.20	Over Speed Trip [M2]	Sets the over speed trip for motor 2.	100.0~720.0 [%]	120.0 [%]	See 8.6
P7.21	Over Speed Trip [M3]	Sets the over speed trip for motor 3.	100.0~720.0 [%]	120.0 [%]	See 8.6
P7.22	Over Speed Trip [M4]	Sets the over speed trip for motor 4.	100.0~720.0 [%]	120.0 [%]	See 8.6
P7.23	SLVC Fail Time[M1]	Sets SLVC fail time for motor 1	0.00~3.00 [s]	0.50 [s]	See 8.6
P7.24	SLVC Fail Time[M2]	Sets SLVC fail time for motor 2	0.00~3.00 [s]	0.50 [s]	See 8.6
P7.25	SLVC Fail Time[M3]	Sets SLVC fail time for motor 3	0.00~3.00 [s]	0.50 [s]	See 8.6
P7.26	SLVC Fail Time [M4]	Sets SLVC fail time for motor 4	0.00~3.00 [s]	0.50 [s]	See 8.6
P7.27	Motor Stall Protection Time[M1]	Sets motor stall protection timefor motor 1	0.00~3.00 [s]	2.00 [s]	
P7.28	Motor Stall Protection Time[M2]	Sets motor stall protection timefor motor2	0.00~3.00 [s]	2.00 [s]	
P7.29	Motor Stall Protection Time[M3]	Sets motor stall protection timefor motor3	0.00~3.00 [s]	2.00 [s]	

P7.30	Motor Stall Protection Time[M4]	Sets motor stall protection timefor motor4	0.00~3.00 [s]	2.00 [s]	
P7.31	Speed Abnormal Range	Sets abnormal speed protection Ratio	0.0~100.0 [%]	25.0 [%]	
P7.32	Speed Abnormal Inspection Time	Sets abnormal speed protection inspection time	0.00~5.00 [s]	1 [s]	
P7.33	Auto-Tuning Fail Time	Sets Auto-Tuning fail inspection time	0.0~1000.0 [s]	360.0 [s]	
P7.47	Continuous Current	Sets allowed long time operational current value	0.0~300.0 [%]	100.0 [%]	See 8.6
P7.48	Over-loaded Current 1	Sets the over-loaded current 1	0.0~300.0 [%]	150.0 [%]	See 8.6
P7.49	OL 1 Time	Sets allowed time of over-loaded current 1	0.00~60.00 [s]	60.00 [s]	See 8.6
P7.50	Over-loaded Current 2	Sets the over-loaded current 2	0.0~300.0 [%]	200.0 [%]	See 8.6
P7.51	OL 2 Time	Sets allowed time of over-loaded current 2	0.00~5.00 [s]	5.00 [s]	See 8.6
P7.55	Lack of Input Phase Protection	[0] Disabled [1] Enabled	0~1	0	
P7.56	Lack of Input Phase @Voltage Dip		0.0~200.0 [%]	120.0 [%]	
P7.57	Lack of Input Phase @Detection Time		0.0~12.0 [s]	5 [s]	
P7.59	Lack of Output Phase Protection	[0] Disabled [1] Enabled	0~1	1	
P7.60	Lack of Output Phase @Detection Time		0.10~3.00 [s]	0.30 [s]	
P7.64	Dynamic Braking Unit	[0] Disabled [1] Enabled	0~1	0	See 8.6
P7.65	DB_START Voltage	Sets the DB_start voltage.	-25~100 [V]	0 [V]	See 8.6
P7.66	DB Full_Action Voltage	Sets the DB full_action voltage.	-25~100 [V]	0 [V]	See 8.6
P7.69	OV SUPRESSION	[0] Disabled [1] Enabled	0~1	0	See 8.6
P7.70	OV SUPRESSION @LIMIT	Sets the over suppression limit.	-25~100 [V]	0 [V]	See 8.6
P7.71	OV SUPRESSION 1	[0] Disabled [1] Enabled	0~1	0	See 8.6
P7.73	UV SUPRESSION	[0] Disabled [1] Enabled	0~1	0	

P7.74	UV SUPRESSION @LIMIT		300~500 [V]	460 [V]	
P7.75	UV SUPRESSION @Action Gain		0.0~1000.0 [%]	100.0 [%]	
P7.76	Motion Recovery Time after UV		0.00~300.00 [s]	1.00 [s]	
P7.77	UV SUPRESSION @Min_Speed		0.0~200.0 [%]	15.0 [%]	
P7.94	Pwr_Motion Option	[0]Run control [1]Busbar voltage control	0~1	1	
P7.95	Percharge Fail Time	Sets percharge fail time in AFE control mode	0.0~3000.0 [s]	15.0 [s]	
P7.96	Pwr_SW Off-Delay	Sets the delay time of Pwr_SW Off.	0.00~300.00 [s]	0.00 [s]	

7.8 Motion Control 1 P8

Par. NO	Parameter Name	Description	Range	Default	Ref. Chapter
P8.0	RUN_SRC	[0] Terminal (DI) [1] Local Operator [2] PROFIBUS [3] MODBUS [4] FREE BLOCK	0~4	0	
P8.1	RUN_SRC @FREE_BLOCK	To issue the Run command via the FREE_BLOCK.			
P8.2	DIR_SRC @FREE_BLOCK	To issue the Direction command via the FREE_BLOCK.			
P8.3	STOP mode	[0] Ramp STOP [1] Free Running STOP	0~1	0	See 8.7
P8.6	START delay	Sets the start delay time.	0.00~300.00 [s]	0.00 [s]	See 8.7
P8.7	STOP_HOLD Time	Sets the stop hold time.	0.00~300.00 [s]	0.00 [s]	See 8.7
P8.10	Speed_Input Source	[0] TERMINAL [1] AI 1 [2] AI 2 [3] LOCAL OPERATOR [4] Profibus DP [5] MODBUS	0~6	0	

		[6] FREE BLOCK			
P8.11	Speed_Src @FREE_BLOCK	To issue the speed given free function block source			
P8.13	Accel_Time Control Source	[0]Prohibited [1]PROFIBUS [2]MODBUS [3]Local setting	0~3	0	See 8.7
P8.14	Accel_Time multiplier		0.1~10.0	1.0	See 8.7
P8.15	Accel 1 @switching	Sets the 1 st accel switch frequency.	0.0~300.0 [%]	100.0 [%]	See 8.7
P8.16	Accel 1 @time	Sets the time to accelerate from 0 to the P8.15.	0.0~300.0 [s]	3.00 [s]	See 8.7
P8.17	Accel 2 @switching	Sets the 2 nd accel switch frequency.	0.0~300.0 [%]	200.0 [%]	See 8.7
P8.18	Accel 2 @time	Sets the time to accelerate from P8.15 to the P8.17.	0.0~300.0 [s]	4.00 [s]	See 8.7
P8.19	Accel 3 @switching	Sets the 3 rd accel switch frequency.	0.0~300.0 [%]	240.0 [%]	See 8.7
P8.20	Accel 3 @time	Sets the time to accelerate from P8.17 to the P8.19.	0.0~300.0 [s]	7.00 [s]	See 8.7
P8.21	Accel 4 @switching	Sets the 4 th accel switch frequency.	0.0~300.0 [%]	300.0 [%]	See 8.7
P8.22	Accel 4 @time	Sets the time to accelerate from P8.19 to the P8.21.	0.0~300.0 [s]	10.00 [s]	See 8.7
P8.23	Accel 5 @switching	Sets the 5 th accel switch frequency.	0.0~300.0 [%]	300.0 [%]	See 8.7
P8.24	Accel 5 @time	Sets the time to accelerate from P8.21 to the P8.23.	0.0~300.0 [s]	10.00 [s]	See 8.7
P8.25	Accel 6 @switching	Sets the 6 th accel switch frequency.	0.0~300.0 [%]	300.0 [%]	See 8.7
P8.26	Accel 6 @time	Sets the time to accelerate from P8.23 to the P8.25.	0.0~300.0 [s]	10.00 [s]	See 8.7
P8.27	Accel 7 @switching	Sets the 7 th accel switch frequency.	0.0~300.0 [%]	300.0 [%]	See 8.7
P8.28	Accel 7 @time	Sets the time to accelerate from P8.25 to the P8.27.	0.0~300.0 [s]	10.00 [s]	See 8.7
P8.29	Accel 8 @switching	Sets the 8 th accel switch frequency.	0.0~300.0	300.0	See 8.7

			[%]	[%]	
P8.30	Accel 8 @time	Sets the time to accelerate from P8.27 to the P8.29.	0.0~300.0 [s]	10.00 [s]	See 8.7
P8.32	Decel_Time Control Time	[0]Prohibited [1]PROFIBUS [2]MODBUS [3]Local setting	0~3	0	See 8.7
P8.33	Decel_Time_Div multiplier		0.1~10.0	1.0	See 8.7
P8.34	Decel 1 @switching	Sets the 1 st decel switch frequency.	0.0~300.0 [%]	100.0 [%]	See 8.7
P8.35	Decel 1 @time	Sets the time to decelerate from P8.34 to the 0.	0.0~300.0 [s]	3.00 [s]	See 8.7
P8.36	Decel 2 @switching	Sets the 2 nd decel switch frequency.	0.0~300.0 [%]	200.0 [%]	See 8.7
P8.37	Decel 2 @time	Sets the time to decelerate from P8.36 to the P8.34.	0.0~300.0 [s]	4.00 [s]	See 8.7
P8.38	Decel 3 @switching	Sets the 3 rd decel switch frequency.	0.0~300.0 [%]	240.0 [%]	See 8.7
P8.39	Decel 3 @time	Sets the time to decelerate from P8.38 to the P8.36.	0.0~300.0 [s]	7.00 [s]	See 8.7
P8.40	Decel 4 @switching	Sets the 4 th decel switch frequency.	0.0~300.0 [%]	300.0 [%]	See 8.7
P8.41	Decel 4 @time	Sets the time to decelerate from P8.40 to the P8.38.	0.0~300.0 [s]	10.00 [s]	See 8.7
P8.42	Decel 5 @switching	Sets the 5 th decel switch frequency.	0.0~300.0 [%]	300.0 [%]	See 8.7
P8.43	Decel 5 @time	Sets the time to decelerate from P8.42 to the P8.40.	0.0~300.0 [s]	10.00 [s]	See 8.7
P8.44	Decel 6 @switching	Sets the 6 th decel switch frequency.	0.0~300.0 [%]	300.0 [%]	See 8.7
P8.45	Decel 6 @time	Sets the time to decelerate from P8.44 to the P8.42.	0.0~300.0 [s]	10.00 [s]	See 8.7
P8.46	Decel 7 @switching	Sets the 7 th decel switch frequency.	0.0~300.0 [%]	300.0 [%]	See 8.7
P8.47	Decel 7 @time	Sets the time to decelerate from P8.46 to the P8.44.	0.0~300.0 [s]	10.00 [s]	See 8.7
P8.48	Decel 8	Sets the 8 th decel switch	0.0~300.0	300.0	See 8.7

	@switching	frequency.	[%]	[%]	
P8.49	Decel 8 @time	Sets the time to decelerate from P8.48 to the P8.46.	0.0~300.0 [s]	10.00 [s]	See 8.7
P8.54	Free Running START_SPEED		0.0~300.0 [%]	0.0 [%]	
P8.55	Counter_Decel	[0] Disabled [1] Enabled	0~1	0	
P8.56	Counter_Decel time		0.00~300.00 [s]	3.00 [s]	
P8.57	E-STOP MODE	[0] Ramp STOP [1] Free Running STOP	0~1	1	
P8.58	E-STOP time		0.00~300.00 [s]	1.50 [s]	

7.9 Motion Control 2 P9

Par. NO	Parameter Name	Description	Range	Default	Ref. Chapter
P9.0	RUN_SRC	[0] Terminal (DI) [1] Local Operator [2] Profibus DP [3] MODBUS [4] FREE BLOCK	0~4	0	
P9.1	RUN_SRC @FREE_BLOCK	To issue the Run command via the FREE_BLOCK.			
P9.2	DIR_SRC @FREE_BLOCK	To issue the Direction command via the FREE_BLOCK.			
P9.3	STOP mode	[0] Ramp STOP [1] Free Running STOP	0~1	0	See 8.7
P9.6	START delay	Sets the start delay time.	0.00~300.00 [s]	0.00 [s]	See 8.7
P9.7	STOP_HOLD Time	Sets the stop hold time.	0.00~300.00 [s]	0.00 [s]	See 8.7
P9.10	Ramp_Input Source	[0] TERMINAL [1] AI 1 [2] AI 2 [3] LOCAL OPERATOR [4] Profibus DP [5] MODBUS [6] FREE BLOCK	0~6	0	

P9.11	Ramp_Src @FREE_BLOCK	To issue the Ramp input source via the FREE_BLOCK.			
P9.13	Accel_Time Control Source	[0]DISABLE [1]PROFIBUS [2]MODBUS [3]Local setting	0~3	0	See 8.7
P9.14	Accel_Time multiplier		0.1~10.0	1.0	See 8.7
P9.15	Accel 1 @switching	Sets the 1 st accel switch frequency.	0.0~300.0 [%]	100.0 [%]	See 8.7
P9.16	Accel 1 @time	Sets the time to accelerate from 0 to the P9.15.	0.0~300.0 [s]	3.00 [s]	See 8.7
P9.17	Accel 2 @switching	Sets the 2 nd accel switch frequency.	0.0~300.0 [%]	200.0 [%]	See 8.7
P9.18	Accel 2 @time	Sets the time to accelerate from P9.15 to the P9.17.	0.0~300.0 [s]	4.00 [s]	See 8.7
P9.19	Accel 3 @switching	Sets the 3 rd accel switch frequency.	0.0~300.0 [%]	240.0 [%]	See 8.7
P9.20	Accel 3 @time	Sets the time to accelerate from P9.17 to the P9.19.	0.0~300.0 [s]	7.00 [s]	See 8.7
P9.21	Accel 4 @switching	Sets the 4 th accel switch frequency.	0.0~300.0 [%]	300.0 [%]	See 8.7
P9.22	Accel 4 @time	Sets the time to accelerate from P9.19 to the P9.21.	0.0~300.0 [s]	10.00 [s]	See 8.7
P9.23	Accel 5 @switching	Sets the 5 th accel switch frequency.	0.0~300.0 [%]	300.0 [%]	See 8.7
P9.24	Accel 5 @time	Sets the time to accelerate from P9.21 to the P9.23.	0.0~300.0 [s]	10.00 [s]	See 8.7
P9.25	Accel 6 @switching	Sets the 6 th accel switch frequency.	0.0~300.0 [%]	300.0 [%]	See 8.7
P9.26	Accel 6 @time	Sets the time to accelerate from P9.23 to the P9.25.	0.0~300.0 [s]	10.00 [s]	See 8.7
P9.27	Accel 7 @switching	Sets the 7 th accel switch frequency.	0.0~300.0 [%]	300.0 [%]	See 8.7
P9.28	Accel 7 @time	Sets the time to accelerate from P9.25 to the P9.27.	0.0~300.0 [s]	10.00 [s]	See 8.7
P9.29	Accel 8 @switching	Sets the 8 th accel switch frequency.	0.0~300.0 [%]	300.0 [%]	See 8.7

P9.30	Accel 8 @time	Sets the time to accelerate from P9.27 to the P9.29.	0.0~300.0 [s]	10.00 [s]	See 8.7
P9.32	Decel_Time Control Source	[0]DISABLE [1]PROFIBUS [2]MODBUS [3]Local setting	0~3	0	See 8.7
P9.33	Decel_Time_Div multiplier		0.1~10.0	1.0	See 8.7
P9.34	Decel 1 @switching	Sets the 1 st decel switch frequency.	0.0~300.0 [%]	100.0 [%]	See 8.7
P9.35	Decel 1 @time	Sets the time to decelerate from P9.34 to the 0.	0.0~300.0 [s]	3.00 [s]	See 8.7
P9.36	Decel 2 @switching	Sets the 2 nd decel switch frequency.	0.0~300.0 [%]	200.0 [%]	See 8.7
P9.37	Decel 2 @time	Sets the time to decelerate from P9.36 to the P9.34.	0.0~300.0 [s]	4.00 [s]	See 8.7
P9.38	Decel 3 @switching	Sets the 3 rd decel switch frequency.	0.0~300.0 [%]	240.0 [%]	See 8.7
P9.39	Decel 3 @time	Sets the time to decelerate from P9.38 to the P9.36.	0.0~300.0 [s]	7.00 [s]	See 8.7
P9.40	Decel 4 @switching	Sets the 4 th decel switch frequency.	0.0~300.0 [%]	300.0 [%]	See 8.7
P9.41	Decel 4 @time	Sets the time to decelerate from P9.40 to the P9.38.	0.0~300.0 [s]	10.00 [s]	See 8.7
P9.42	Decel 5 @switching	Sets the 5 th decel switch frequency.	0.0~300.0 [%]	300.0 [%]	See 8.7
P9.43	Decel 5 @time	Sets the time to decelerate from P9.42 to the P9.40.	0.0~300.0 [s]	10.00 [s]	See 8.7
P9.44	Decel 6 @switching	Sets the 6 th decel switch frequency.	0.0~300.0 [%]	300.0 [%]	See 8.7
P9.45	Decel 6 @time	Sets the time to decelerate from P9.44 to the P9.42.	0.0~300.0 [s]	10.00 [s]	See 8.7
P9.46	Decel 7 @switching	Sets the 7 th decel switch frequency.	0.0~300.0 [%]	300.0 [%]	See 8.7
P9.47	Decel 7 @time	Sets the time to decelerate from P9.46 to the P9.44.	0.0~300.0 [s]	10.00 [s]	See 8.7
P9.48	Decel 8 @switching	Sets the 8 th decel switch frequency.	0.0~300.0 [%]	300.0 [%]	See 8.7

P9.49	Decel 8 @time	Sets the time to decelerate from P9.48 to the P9.46.	0.0~300.0 [s]	10.00 [s]	See 8.7
P9.54	Free Running START_SPEED		0.0~300.0 [%]	0.0 [%]	
P9.55	Counter_Decel	[0] Disabled [1] Enabled	0~1	0	
P9.56	Counter_Decel time		0.00~300.00 [s]	3.00 [s]	
P9.57	E-STOP MODE	[0] Ramp STOP [1] Free Running STOP	0~1	1	
P9.58	E-STOP time		0.00~300.00 [s]	1.50 [s]	

7.10 Motion Control 3 P10

Par. NO	Parameter Name	Description	Range	Default	Ref. Chapter
P10.0	RUN_SRC	[0] Terminal (DI) [1] Local Operator [2] Profibus DP [3] MODBUS [4] FREE BLOCK	0~4	0	
P10.1	RUN_SRC @FREE_BLOCK	To issue the Run command via the FREE_BLOCK.			
P10.2	DIR_SRC @FREE_BLOCK	To issue the Direction command via the FREE_BLOCK.			
P10.3	STOP mode	[0] Ramp STOP [1] Free Running STOP	0~1	0	See 8.7
P10.6	START delay	Sets the start delay time.	0.00~300.00 [s]	0.00 [s]	See 8.7
P10.7	STOP_HOLD Time	Sets the stop hold time.	0.00~300.00 [s]	0.00 [s]	See 8.7
P10.10	Speed_Input Source	[0] TERMINAL [1] AI 1 [2] AI 2 [3] LOCAL OPERATOR [4] Profibus DP [5] MODBUS [6] FREE BLOCK	0~6	0	
P10.11	Speed_Src @FREE_BLOCK	To issue the speed given free function block source			

P10.13	Accel_Time Control Source	[0]DISABLE [1]PROFIBUS [2]MODBUS [3]Local setting	0~3	0	See 8.7
P10.14	Accel_Time multiplier		0.1~10.0	1.0	See 8.7
P10.15	Accel 1 @switching	Sets the 1 st accel switch frequency.	0.0~300.0 [%]	100.0 [%]	See 8.7
P10.16	Accel 1 @time	Sets the time to accelerate from 0 to the P10.15.	0.0~300.0 [s]	3.00 [s]	See 8.7
P10.17	Accel 2 @switching	Sets the 2 nd accel switch frequency.	0.0~300.0 [%]	200.0 [%]	See 8.7
P10.18	Accel 2 @time	Sets the time to accelerate from P10.15 to the P10.17.	0.0~300.0 [s]	4.00 [s]	See 8.7
P10.19	Accel 3 @switching	Sets the 3 rd accel switch frequency.	0.0~300.0 [%]	240.0 [%]	See 8.7
P10.20	Accel 3 @time	Sets the time to accelerate from P10.17 to the P10.19.	0.0~300.0 [s]	7.00 [s]	See 8.7
P10.21	Accel 4 @switching	Sets the 4 th accel switch frequency.	0.0~300.0 [%]	300.0 [%]	See 8.7
P10.22	Accel 4 @time	Sets the time to accelerate from P10.19 to the P10.21.	0.0~300.0 [s]	10.00 [s]	See 8.7
P10.23	Accel 5 @switching	Sets the 5 th accel switch frequency.	0.0~300.0 [%]	300.0 [%]	See 8.7
P10.24	Accel 5 @time	Sets the time to accelerate from P10.21 to the P10.23.	0.0~300.0 [s]	10.00 [s]	See 8.7
P10.25	Accel 6 @switching	Sets the 6 th accel switch frequency.	0.0~300.0 [%]	300.0 [%]	See 8.7
P10.26	Accel 6 @time	Sets the time to accelerate from P10.23 to the P10.25.	0.0~300.0 [s]	10.00 [s]	See 8.7
P10.27	Accel 7 @switching	Sets the 7 th accel switch frequency.	0.0~300.0 [%]	300.0 [%]	See 8.7
P10.28	Accel 7 @time	Sets the time to accelerate from P10.25 to the P10.27.	0.0~300.0 [s]	10.00 [s]	See 8.7
P10.29	Accel 8 @switching	Sets the 8 th accel switch frequency.	0.0~300.0 [%]	300.0 [%]	See 8.7
P10.30	Accel 8 @time	Sets the time to accelerate from P10.27 to the P10.29.	0.0~300.0 [s]	10.00 [s]	See 8.7

P10.32	Decel_Time Control Source	[0]DISABLE [1]PROFIBUS [2]MODBUS [3]Local setting	0~3	0	See 8.7
P10.33	Decel_Time_Div multiplier		0.1~10.0	1.0	See 8.7
P10.34	Decel 1 @switching	Sets the 1 st decel switch frequency.	0.0~300.0 [%]	100.0 [%]	See 8.7
P10.35	Decel 1 @time	Sets the time to decelerate from P10.34 to the 0.	0.0~300.0 [s]	3.00 [s]	See 8.7
P10.36	Decel 2 @switching	Sets the 2 nd decel switch frequency.	0.0~300.0 [%]	200.0 [%]	See 8.7
P10.37	Decel 2 @time	Sets the time to decelerate from P10.36 to the P10.34.	0.0~300.0 [s]	4.00 [s]	See 8.7
P10.38	Decel 3 @switching	Sets the 3 rd decel switch frequency.	0.0~300.0 [%]	240.0 [%]	See 8.7
P10.39	Decel 3 @time	Sets the time to decelerate from P10.38 to the P10.36.	0.0~300.0 [s]	7.00 [s]	See 8.7
P10.40	Decel 4 @switching	Sets the 4 th decel switch frequency.	0.0~300.0 [%]	300.0 [%]	See 8.7
P10.41	Decel 4 @time	Sets the time to decelerate from P10.40 to the P10.38.	0.0~300.0 [s]	10.00 [s]	See 8.7
P10.42	Decel 5 @switching	Sets the 5 th decel switch frequency.	0.0~300.0 [%]	300.0 [%]	See 8.7
P10.43	Decel 5 @time	Sets the time to decelerate from P10.42 to the P10.40.	0.0~300.0 [s]	10.00 [s]	See 8.7
P10.44	Decel 6 @switching	Sets the 6 th decel switch frequency.	0.0~300.0 [%]	300.0 [%]	See 8.7
P10.45	Decel 6 @time	Sets the time to decelerate from P10.44 to the P10.42.	0.0~300.0 [s]	10.00 [s]	See 8.7
P10.46	Decel 7 @switching	Sets the 7 th decel switch frequency.	0.0~300.0 [%]	300.0 [%]	See 8.7
P10.47	Decel 7 @time	Sets the time to decelerate from P10.46 to the P10.44.	0.0~300.0 [s]	10.00 [s]	See 8.7
P10.48	Decel 8 @switching	Sets the 8 th decel switch frequency.	0.0~300.0 [%]	300.0 [%]	See 8.7
P10.49	Decel 8 @time	Sets the time to decelerate from P10.48 to the P10.46.	0.0~300.0 [s]	10.00 [s]	See 8.7

P10.54	Free Running START_SPEED		0.0~300.0 [%]	0.0 [%]	
P10.55	Counter_Decel	[0] Disabled [1] Enabled	0~1	0	
P10.56	Counter_Decel time		0.00~300.00 [s]	3.00 [s]	
P10.57	E-STOP MODE	[0] Ramp STOP [1] Free Running STOP	0~1	1	
P10.58	E-STOP time		0.00~300.00 [s]	1.50 [s]	

7.11 Motion Control 4 P11

Par. NO	Parameter Name	Description	Range	Default	Ref. Chapter
P11.0	RUN_SRC	[0] Terminal (DI) [1] Local Operator [2] Profibus DP [3] MODBUS [4] FREE BLOCK	0~4	0	
P11.1	RUN_SRC @FREE_BLOCK	To issue the Run command via the FREE_BLOCK.			
P11.2	DIR_SRC @FREE_BLOCK	To issue the Direction command via the FREE_BLOCK.			
P11.3	STOP mode	[0] Ramp STOP [1] Free Running STOP	0~1	0	See 8.7
P11.6	START delay	Sets the start delay time.	0.00~300.00 [s]	0.00 [s]	See 8.7
P11.7	STOP_HOLD Time	Sets the stop hold time.	0.00~300.00 [s]	0.00 [s]	See 8.7
P11.10	Speed_Input Source	[0] TERMINAL [1] AI 1 [2] AI 2 [3] LOCAL OPERATOR [4] Profibus DP [5] MODBUS [6] FREE BLOCK	0~6	0	
P11.11	Speed_Src @FREE_BLOCK	To issue the speed given free function block source			
P11.13	Accel_Time	[0]DISABLE [1]PROFIBUS	0~3	0	See 8.7

	Control Source	[2]MODBUS [3]Local setting			
P11.14	Accel_Time multiplier		0.1~10.0	1.0	See 8.7
P11.15	Accel 1 @switching	Sets the 1 st accel switch frequency.	0.0~300.0 [%]	100.0 [%]	See 8.7
P11.16	Accel 1 @time	Sets the time to accelerate from 0 to the P11.15.	0.0~300.0 [s]	3.00 [s]	See 8.7
P11.17	Accel 2 @switching	Sets the 2 nd accel switch frequency.	0.0~300.0 [%]	200.0 [%]	See 8.7
P11.18	Accel 2 @time	Sets the time to accelerate from P11.15 to the P11.17.	0.0~300.0 [s]	4.00 [s]	See 8.7
P11.19	Accel 3 @switching	Sets the 3 rd accel switch frequency.	0.0~300.0 [%]	240.0 [%]	See 8.7
P11.20	Accel 3 @time	Sets the time to accelerate from P11.17 to the P11.19.	0.0~300.0 [s]	7.00 [s]	See 8.7
P11.21	Accel 4 @switching	Sets the 4 th accel switch frequency.	0.0~300.0 [%]	300.0 [%]	See 8.7
P11.22	Accel 4 @time	Sets the time to accelerate from P11.19 to the P11.21.	0.0~300.0 [s]	10.00 [s]	See 8.7
P11.23	Accel 5 @switching	Sets the 5 th accel switch frequency.	0.0~300.0 [%]	300.0 [%]	See 8.7
P11.24	Accel 5 @time	Sets the time to accelerate from P11.21 to the P11.23.	0.0~300.0 [s]	10.00 [s]	See 8.7
P11.25	Accel 6 @switching	Sets the 6 th accel switch frequency.	0.0~300.0 [%]	300.0 [%]	See 8.7
P11.26	Accel 6 @time	Sets the time to accelerate from P11.23 to the P11.25.	0.0~300.0 [s]	10.00 [s]	See 8.7
P11.27	Accel 7 @switching	Sets the 7 th accel switch frequency.	0.0~300.0 [%]	300.0 [%]	See 8.7
P11.28	Accel 7 @time	Sets the time to accelerate from P11.25 to the P11.27.	0.0~300.0 [s]	10.00 [s]	See 8.7
P11.29	Accel 8 @switching	Sets the 8 th accel switch frequency.	0.0~300.0 [%]	300.0 [%]	See 8.7
P11.30	Accel 8 @time	Sets the time to accelerate from P11.27 to the P11.29.	0.0~300.0 [s]	10.00 [s]	See 8.7
P11.32	Decel_Time Control Source	[0]DISABLE [1]PROFIBUS	0~3	0	See 8.7

		[2]MODBUS [3]Local setting			
P11.33	Decel_Time_Div multiplier		0.1~10.0	1.0	See 8.7
P11.34	Decel 1 @switching	Sets the 1 st decel switch frequency.	0.0~300.0 [%]	100.0 [%]	See 8.7
P11.35	Decel 1 @time	Sets the time to decelerate from P11.34 to the 0.	0.0~300.0 [s]	3.00 [s]	See 8.7
P11.36	Decel 2 @switching	Sets the 2 nd decel switch frequency.	0.0~300.0 [%]	200.0 [%]	See 8.7
P11.37	Decel 2 @time	Sets the time to decelerate from P11.36 to the P11.34.	0.0~300.0 [s]	4.00 [s]	See 8.7
P11.38	Decel 3 @switching	Sets the 3 rd decel switch frequency.	0.0~300.0 [%]	240.0 [%]	See 8.7
P11.39	Decel 3 @time	Sets the time to decelerate from P11.38 to the P11.36.	0.0~300.0 [s]	7.00 [s]	See 8.7
P11.40	Decel 4 @switching	Sets the 4 th decel switch frequency.	0.0~300.0 [%]	300.0 [%]	See 8.7
P11.41	Decel 4 @time	Sets the time to decelerate from P11.40 to the P11.38.	0.0~300.0 [s]	10.00 [s]	See 8.7
P11.42	Decel 5 @switching	Sets the 5 th decel switch frequency.	0.0~300.0 [%]	300.0 [%]	See 8.7
P11.43	Decel 5 @time	Sets the time to decelerate from P11.42 to the P11.40.	0.0~300.0 [s]	10.00 [s]	See 8.7
P11.44	Decel 6 @switching	Sets the 6 th decel switch frequency.	0.0~300.0 [%]	300.0 [%]	See 8.7
P11.45	Decel 6 @time	Sets the time to decelerate from P11.44 to the P11.42.	0.0~300.0 [s]	10.00 [s]	See 8.7
P11.46	Decel 7 @switching	Sets the 7 th decel switch frequency.	0.0~300.0 [%]	300.0 [%]	See 8.7
P11.47	Decel 7 @time	Sets the time to decelerate from P11.46 to the P11.44.	0.0~300.0 [s]	10.00 [s]	See 8.7
P11.48	Decel 8 @switching	Sets the 8 th decel switch frequency.	0.0~300.0 [%]	300.0 [%]	See 8.7
P11.49	Decel 8 @time	Sets the time to decelerate from P11.48 to the P11.46.	0.0~300.0 [s]	10.00 [s]	See 8.7
P11.54	Free Running START_SPEED		0.0~300.0 [%]	0.0 [%]	

P11.55	Counter_Decel	[0] Disabled [1] Enabled	0~1	0	
P11.56	Counter_Decel time		0.00~300.00 [s]	3.00 [s]	
P11.57	E-STOP MODE	[0] Ramp STOP [1] Free Running STOP	0~1	1	
P11.58	E-STOP time		0.00~300.00 [s]	1.50 [s]	

7.12 Motor 1 Step Speed Brake Set P12

Par. NO	Parameter Name	Description	Range	Default	Ref. Chapter
P12.0	Multi-step MODE	[0] Direct Step Input [1] Bit Decoding	0~1	1	See 8.8
P12.1	Multi-step Unit	[0] [%] [1] [Hz] [2] [rpm]	0~2	1	
P12.2	MSTEP @step 1		0.0~3000.0	10.0	
P12.3	MSTEP @step 2		0.0~3000.0	20.0	
P12.4	MSTEP @step 3		0.0~3000.0	35.0	
P12.5	MSTEP @step 4		0.0~3000.0	50.0	
P12.6	MSTEP @step 5		0.0~3000.0	50.0	
P12.7	MSTEP @step 6		0.0~3000.0	50.0	
P12.8	MSTEP @step 7		0.0~3000.0	50.0	
P12.9	MSTEP @step 8		0.0~3000.0	50.0	
P12.10	MSTEP @step 9		0.0~3000.0	50.0	
P12.11	MSTEP @step 10		0.0~3000.0	50.0	
P12.12	MSTEP @step 11		0.0~3000.0	50.0	
P12.13	MSTEP @step 12		0.0~3000.0	50.0	
P12.14	MSTEP @step 13		0.0~3000.0	50.0	
P12.15	MSTEP @step 14		0.0~3000.0	50.0	
P12.16	MSTEP @step 15		0.0~3000.0	50.0	
P12.17	MSTEP @step 16		0.0~3000.0	50.0	
P12.22	Brake Release @speed	Sets the brake release speed when in forward.	0.0~20.0 [%]	2.0 [%]	See 8.8

P12.23	Brake Release @Rev_Speed	Sets the brake release speed when in reverse.	0.0~20.0 [%]	0.0 [%]	See 8.8
P12.24	Brake Release @Torque	Sets the brake release torque when in forward..	0.0~200.0 [%]	30.0 [%]	See 8.8
P12.25	Brake Release @Rev_Torque	Sets the brake release torque when in reverse.	0.0~200.0 [%]	20.0 [%]	See 8.8
P12.26	Brake Release_Ctrl @Delay_time		0.00~2.00 [s]	0.00 [s]	See 8.8
P12.27	Brake Release_Ctrl @RevSpd Delay_time		0.00~2.00 [s]	0.00 [s]	See 8.8
P12.28	Brake Release @Delay_time	Sets the delay time of brake release when in forward.	0.00~2.00 [s]	0.07 [s]	See 8.8
P12.29	Brake Release @RevSpd Delay_time	Sets the delay time of brake release when in reverse.	0.00~2.00 [s]	0.07 [s]	See 8.8
P12.32	Brake Closure @speed	Sets the brake closure speed when in forward.	0.0~20.0 [%]	0.0 [%]	See 8.8
P12.33	Brake Closure @Rev_Speed	Sets the brake closure speed when in reverse.	0.0~20.0 [%]	0.0 [%]	See 8.8
P12.34	Brake Closure @Delay_time	Sets the delay time of brake closure when in forward.	0.00~2.00 [s]	0.00 [s]	See 8.8
P12.35	Brake Closure @Rev_Delay_time	Sets the delay time of brake closure when in reverse.	0.00~2.00 [s]	0.00 [s]	See 8.8
P12.36	Brake Closure @time	Sets the brake closure time when in forward.	0.00~2.00 [s]	0.50 [s]	See 8.8
P12.37	Brake Closure @Rev_time	Sets the brake closure time when in reverse.	0.00~2.00 [s]	0.50 [s]	See 8.8

7.13 Motor 2 Step Speed Brake Set P13

Par. NO	Parameter Name	Description	Range	Default	Ref. Chapter
P13.0	Multi-step MODE	[0] Direct Step Input [1] Bit Decoding	0~1	1	See 8.8

P13.1	Multi-step Unit	[0] [%] [1] [Hz] [2] [rpm]	0~2	1	
P13.2	MSTEP @step 1		0.0~3000.0	10.0	
P13.3	MSTEP @step 2		0.0~3000.0	20.0	
P13.4	MSTEP @step 3		0.0~3000.0	35.0	
P13.5	MSTEP @step 4		0.0~3000.0	50.0	
P13.6	MSTEP @step 5		0.0~3000.0	50.0	
P13.7	MSTEP @step 6		0.0~3000.0	50.0	
P13.8	MSTEP @step 7		0.0~3000.0	50.0	
P13.9	MSTEP @step 8		0.0~3000.0	50.0	
P13.10	MSTEP @step 9		0.0~3000.0	50.0	
P13.11	MSTEP @step 10		0.0~3000.0	50.0	
P13.12	MSTEP @step 11		0.0~3000.0	50.0	
P13.13	MSTEP @step 12		0.0~3000.0	50.0	
P13.14	MSTEP @step 13		0.0~3000.0	50.0	
P13.15	MSTEP @step 14		0.0~3000.0	50.0	
P13.16	MSTEP @step 15		0.0~3000.0	50.0	
P13.17	MSTEP @step 16		0.0~3000.0	50.0	
P13.22	Brake Release @speed	Sets the brake release speed when in forward.	0.0~20.0 [%]	2.0 [%]	See 8.8
P13.23	Brake Release @Rev_Speed	Sets the brake release speed when in reverse.	0.0~20.0 [%]	0.0 [%]	See 8.8
P13.24	Brake Release @Torque	Sets the brake release torque when in forward..	0.0~200.0 [%]	30.0 [%]	See 8.8
P13.25	Brake Release @Rev_Torque	Sets the brake release torque when in reverse.	0.0~200.0 [%]	20.0 [%]	See 8.8
P13.26	Brake Release_Ctrl @Delay_time		0.00~2.00 [s]	0.00 [s]	See 8.8
P13.27	Brake Release_Ctrl @RevSpd Delay_time		0.00~2.00 [s]	0.00 [s]	See 8.8
P13.28	Brake Release @Delay_time	Sets the delay time of brake release when in forward.	0.00~2.00 [s]	0.07 [s]	See 8.8

P13.29	Brake Release @RevSpd Delay_time	Sets the delay time of brake release when in reverse.	0.00~2.00 [s]	0.07 [s]	See 8.8
P13.32	Brake Closure @speed	Sets the brake closure speed when in forward.	0.0~20.0 [%]	0.0 [%]	See 8.8
P13.33	Brake Closure @Rev_Speed	Sets the brake closure speed when in reverse.	0.0~20.0 [%]	0.0 [%]	See 8.8
P13.34	Brake Closure @Delay_time	Sets the delay time of brake closure when in forward.	0.00~2.00 [s]	0.00 [s]	See 8.8
P13.35	Brake Closure @Rev_Delay_time	Sets the delay time of brake closure when in reverse.	0.00~2.00 [s]	0.00 [s]	See 8.8
P13.36	Brake Closure @time	Sets the brake closure time when in forward.	0.00~2.00 [s]	0.50 [s]	See 8.8
P13.37	Brake Closure @Rev_time	Sets the brake closure time when in reverse.	0.00~2.00 [s]	0.50 [s]	See 8.8

7.14 Motor 3 Step Speed Brake Set P14

Par. NO	Parameter Name	Description	Range	Default	Ref. Chapter
P14.0	Multi-step MODE	[0] Direct Step Input [1] Bit Decoding	0~1	1	See 8.8
P14.1	Multi-step Unit	[0] [%] [1] [Hz] [2] [rpm]	0~2	1	
P14.2	MSTEP @step 1		0.0~3000.0	10.0	
P14.3	MSTEP @step 2		0.0~3000.0	20.0	
P14.4	MSTEP @step 3		0.0~3000.0	35.0	
P14.5	MSTEP @step 4		0.0~3000.0	50.0	
P14.6	MSTEP @step 5		0.0~3000.0	50.0	
P14.7	MSTEP @step 6		0.0~3000.0	50.0	
P14.8	MSTEP @step 7		0.0~3000.0	50.0	
P14.9	MSTEP @step 8		0.0~3000.0	50.0	
P14.10	MSTEP @step 9		0.0~3000.0	50.0	
P14.11	MSTEP @step 10		0.0~3000.0	50.0	
P14.12	MSTEP @step 11		0.0~3000.0	50.0	
P14.13	MSTEP @step 12		0.0~3000.0	50.0	

P14.14	MSTEP @step 13		0.0~3000.0	50.0	
P14.15	MSTEP @step 14		0.0~3000.0	50.0	
P14.16	MSTEP @step 15		0.0~3000.0	50.0	
P14.17	MSTEP @step 16		0.0~3000.0	50.0	
P14.22	Brake Release @speed	Sets the brake release speed when in forward.	0.0~20.0 [%]	2.0 [%]	See 8.8
P14.23	Brake Release @Rev_Speed	Sets the brake release speed when in reverse.	0.0~20.0 [%]	0.0 [%]	See 8.8
P14.24	Brake Release @Torque	Sets the brake release torque when in forward..	0.0~200.0 [%]	30.0 [%]	See 8.8
P14.25	Brake Release @Rev_Torque	Sets the brake release torque when in reverse.	0.0~200.0 [%]	20.0 [%]	See 8.8
P14.26	Brake Release_Ctrl @Delay_time		0.00~2.00 [s]	0.00 [s]	See 8.8
P14.27	Brake Release_Ctrl @RevSpd Delay_time		0.00~2.00 [s]	0.00 [s]	See 8.8
P14.28	Brake Release @Delay_time	Sets the delay time of brake release when in forward.	0.00~2.00 [s]	0.07 [s]	See 8.8
P14.29	Brake Release @RevSpd Delay_time	Sets the delay time of brake release when in reverse.	0.00~2.00 [s]	0.07 [s]	See 8.8
P14.32	Brake Closure @speed	Sets the brake closure speed when in forward.	0.0~20.0 [%]	0.0 [%]	See 8.8
P14.33	Brake Closure @Rev_Speed	Sets the brake closure speed when in reverse.	0.0~20.0 [%]	0.0 [%]	See 8.8
P14.34	Brake Closure @Delay_time	Sets the delay time of brake closure when in forward.	0.00~2.00 [s]	0.00 [s]	See 8.8
P14.35	Brake Closure @Rev_Delay_time	Sets the delay time of brake closure when in reverse.	0.00~2.00 [s]	0.00 [s]	See 8.8
P14.36	Brake Closure @time	Sets the brake closure time when in forward.	0.00~2.00 [s]	0.50 [s]	See 8.8
P14.37	Brake Closure @Rev_time	Sets the brake closure time when in reverse.	0.00~2.00 [s]	0.50 [s]	See 8.8

7.15 Motor 4 Step Speed Brake Set P15

Par. NO	Parameter Name	Description	Range	Default	Ref. Chapter
P15.0	Multi-step MODE	[0] Direct Step Input [1] Bit Decoding	0~1	1	See 8.8
P15.1	Multi-step Unit	[0] [%] [1] [Hz] [2] [rpm]	0~2	1	
P15.2	MSTEP @step 1		0.0~3000.0	10.0	
P15.3	MSTEP @step 2		0.0~3000.0	20.0	
P15.4	MSTEP @step 3		0.0~3000.0	35.0	
P15.5	MSTEP @step 4		0.0~3000.0	50.0	
P15.6	MSTEP @step 5		0.0~3000.0	50.0	
P15.7	MSTEP @step 6		0.0~3000.0	50.0	
P15.8	MSTEP @step 7		0.0~3000.0	50.0	
P15.9	MSTEP @step 8		0.0~3000.0	50.0	
P15.10	MSTEP @step 9		0.0~3000.0	50.0	
P15.11	MSTEP @step 10		0.0~3000.0	50.0	
P15.12	MSTEP @step 11		0.0~3000.0	50.0	
P15.13	MSTEP @step 12		0.0~3000.0	50.0	
P15.14	MSTEP @step 13		0.0~3000.0	50.0	
P15.15	MSTEP @step 14		0.0~3000.0	50.0	
P15.16	MSTEP @step 15		0.0~3000.0	50.0	
P15.17	MSTEP @step 16		0.0~3000.0	50.0	
P15.22	Brake Release @speed	Sets the brake release speed when in forward.	0.0~20.0 [%]	2.0 [%]	See 8.8
P15.23	Brake Release @Rev_Speed	Sets the brake release speed when in reverse.	0.0~20.0 [%]	0.0 [%]	See 8.8
P15.24	Brake Release @Torque	Sets the brake release torque when in forward..	0.0~200.0 [%]	30.0 [%]	See 8.8
P15.25	Brake Release @Rev_Torque	Sets the brake release torque when in reverse.	0.0~200.0 [%]	20.0 [%]	See 8.8
P15.26	Brake Release_Ctrl @Delay_time		0.00~2.00 [s]	0.00 [s]	See 8.8

P15.27	Brake Release_Ctrl @RevSpd Delay_time		0.00~2.00 [s]	0.00 [s]	See 8.8
P15.28	Brake Release @Delay_time	Sets the delay time of brake release when in forward.	0.00~2.00 [s]	0.07 [s]	See 8.8
P15.29	Brake Release @RevSpd Delay_time	Sets the delay time of brake release when in reverse.	0.00~2.00 [s]	0.07 [s]	See 8.8
P15.32	Brake Closure @speed	Sets the brake closure speed when in forward.	0.0~20.0 [%]	0.0 [%]	See 8.8
P15.33	Brake Closure @Rev_Speed	Sets the brake closure speed when in reverse.	0.0~20.0 [%]	0.0 [%]	See 8.8
P15.34	Brake Closure @Delay_time	Sets the delay time of brake closure when in forward.	0.00~2.00 [s]	0.00 [s]	See 8.8
P15.35	Brake Closure @Rev_Delay_time	Sets the delay time of brake closure when in reverse.	0.00~2.00 [s]	0.00 [s]	See 8.8
P15.36	Brake Closure @time	Sets the brake closure time when in forward.	0.00~2.00 [s]	0.50 [s]	See 8.8
P15.37	Brake Closure @Rev_time	Sets the brake closure time when in reverse.	0.00~2.00 [s]	0.50 [s]	See 8.8

7.16 Motor 1 Parameter V/F Set P16

Par. NO	Parameter Name	Description	Range	Default	Ref. Chapter
P16.0	Supply Voltage	Sets the supply voltage.	320~480 [V]	380 [V]	
P16.2	Nominal Power	Sets parameter based on motor nameplate	0.0~4000.0 [kW]	Model dependent [kW]	
P16.3	Nominal Voltage	Sets parameter based on motor nameplate	320~480 [V]	380 [V]	
P16.4	Nominal Current	Sets parameter based on motor nameplate	0.0~6500.0 [A]	Model dependent [A]	
P16.5	Nominal Frequency	Sets parameter based on motor nameplate	0.0~300.0 [Hz]	50.0 [Hz]	
P16.6	Nominal Speed	Sets parameter based on motor nameplate	0~6000 [rpm]	1465 [rpm]	

P16.7	Number of Poles	Sets parameter based on motor nameplate	2~12 [pole]	4 [pole]	See 8.9
P16.9	Synchronous Speed	Sets parameter based on motor nameplate	0~7200 [rpm]	1500 [rpm]	See 8.9
P16.11	Basic Control Function	[0] V/F [1] S/L Vector Control [2] CL Vector Control [3] Line Converter Control (AFE) [4] Line Active Power Filter	0~4	0	
P16.12	PWM @Carrier Frequency	Sets the carrier frequency.	1.00~10.00 [kHz]	3.00 [kHz]	See 8.9
P16.14	V/F Curve Pattern	[0] Linear Curve V/F [1] Multi-point Curve V/F [2] Square Curve V/F	0~3	0	See 8.9
P16.15	Torque Compensation	[0] Disabled [1] Enabled	0~1	0	See 8.9
P16.16	Torque Compensation Time	Sets torque compensation time	2~500 [ms]	500 [ms]	
P16.17	V/F Control Mode	[0] V/F Frequency Control [1] Slip Compensated Speed Control	0~1	0	
P16.18	Slip Compensation Time	Sets the slip compensation time.	10~1000 [ms]	200 [ms]	
P16.19	Stator Resistance Auto-Tuning Option	[0] Online [1] Offline	0~1	0	
P16.22	Delay Time @START	Sets the delay time at start.	0.00~100.00 [s]	0.00 [s]	See 8.9
P16.23	Min. Frequency	Sets the minimum frequency (valid only when running in V/F control mode).	0.00~300.00 [Hz]	0.00 [Hz]	
P16.24	Max. Frequency	Sets the maximum frequency (valid only when running in V/F control mode).	0.00~300.00 [Hz]	50.00 [Hz]	
P16.25	Max. Modulation Ratio	Sets the maximum modulation ratio.	0.0~120.0 [%]	100.0 [%]	
P16.26	V/F DC offset	Sets the V/F DC offset at start.	0.00~10.00 [%]	0.75 [%]	See 8.9

P16.27	Nominal Frequency Voltage	Sets the output voltage at nominal frequency.	0.0~200.0 [%]	100.0 [%]	See 8.9
P16.30	Square Curve Voltage Compensation @START	Sets the square curve voltage compensation at start.	0.0~100.0 [%]	0.0 [%]	See 8.9
P16.33	Number of V/F points	Sets the number of V/F points	0~6	2	See 8.9
P16.34	V/F point @F1		0.0~300.0 [Hz]	5.0 [Hz]	
P16.35	V/F point @V1		0.0~125.0 [%]	11.5 [%]	
P16.36	V/F point @F2		0.0~300.0 [Hz]	50.0 [Hz]	
P16.37	V/F point @V2		0.0~125.0 [%]	100.0 [%]	
P16.38	V/F point @F3		0.0~300.0 [Hz]	50.0 [Hz]	
P16.39	V/F point @V3		0.0~125.0 [%]	100.0 [%]	
P16.40	V/F point @F4		0.0~300.0 [Hz]	50.0 [Hz]	
P16.41	V/F point @V4		0.0~125.0 [%]	100.0 [%]	
P16.42	V/F point @F5		0.0~300.0 [Hz]	50.0 [Hz]	
P16.43	V/F point @V5		0.0~125.0 [%]	100.0 [%]	
P16.44	V/F point @F6		0.0~300.0 [Hz]	50.0 [Hz]	
P16.45	V/F point @V6		0.0~125.0 [%]	100.0 [%]	
P16.46	V/F Curve @FREE_BLOCK		0~300	0	
P16.47	Voltage_ADJ @FREE_BLOCK		0~300	0	
P16.48	Frequency_Adj_SRC	[0]DISABLE [1] PID BLOCK 1 [2] PID BLOCK 2 [3] FREE BLOCK	0~3	0	
P16.49	Frequency_ADJ @FREE_BLOCK	0~300	0~300	0	
P16.50	START_DC_Braking @time	Sets the time of START_DC_Braking.	0.00~300.00 [s]	0.00 [s]	See 8.9
P16.51	START_DC_Braking	Sets the current of	0.0~150.0	70.0	See 8.9

	@current	START_DC_Braking.	[%]	[%]	
P16.52	START_DC_Braking @frequency	Sets the frequency of START_DC_Braking.	0.00~5.00 [Hz]	0.00 [Hz]	See 8.9
P16.54	STOP_DC_Braking @time	Sets the time of STOP_DC_Braking.	0.00~300.00 [s]	0.00 [s]	See 8.9
P16.55	STOP_DC_Braking @current	Sets the current of STOP_DC_Braking.	0.0~150.0 [%]	75.0 [%]	See 8.9
P16.56	STOP_DC_Braking @frequency	Sets the frequency of STOP_DC_Braking.	0.00~5.00 [Hz]	0.00 [Hz]	See 8.9
P16.59	Kp_OC_Protection	Sets over currentprotection Ratio	0.0~1000.0 [%]	100.0 [%]	
P16.60	Ki_OC_Protection	Sets over current protection integral	0.0~1000.0 [%]	100.0 [%]	
P16.61	Kp_OV_Limiter	Sets over voltage protection Ratio	0.0~1000.0 [%]	100.0 [%]	
P16.62	Ki_OV_Limiter	Sets over voltage protection integral	0.0~1000.0 [%]	100.0 [%]	
P16.64	V/F Stabilization @Gain	Sets the gain of V/F stabilization.	0.0~1000.0 [%]	100.0 [%]	See 8.9
P16.66	V/F Stabilization @Limit	Sets the limit of V/F stabilization.	0.0~1000.0 [%]	100.0 [%]	
P16.67	Start DC Brake Ratio	Sets start DC brake Ratio	0.0~1000.0 [%]	100.0 [%]	
P16.68	Start DC Brake Integral	Sets start DC brake integral	0.0~1000.0 [%]	100.0 [%]	
P16.69	Stop DC Brake Ratio	Sets stop DC brake Ratio	0.0~1000.0 [%]	100.0 [%]	
P16.70	Stop DC Brake Integral	Sets stop DC brake integral	0.0~1000.0 [%]	100.0 [%]	

7.17 Motor 2 Parameter V/F Set P17

Par. NO	Parameter Name	Description	Range	Default	Ref. Chapter
P17.0	Supply Voltage	Sets based on actual supply voltage	320~480 [V]	380 [V]	
P17.2	Nominal Power	Sets parameter based on motor nameplate	0.0~4000.0 [kW]	Model dependent [kW]	
P17.3	Nominal Voltage	Sets parameter based on	320~480	380	

		motor nameplate	[V]	[V]	
P17.4	Nominal Current	Sets parameter based on motor nameplate	0.0~6500.0 [A]	Model dependent [A]	
P17.5	Nominal Frequency	Sets parameter based on motor nameplate	0.0~300.0 [Hz]	50.0 [Hz]	
P17.6	Nominal Speed	Sets parameter based on motor nameplate	0~6000 [rpm]	1465 [rpm]	
P17.7	Number of Poles	Sets parameter based on motor nameplate	2~12 [pole]	4 [pole]	See 8.9
P17.9	Motor Synchronous Speed	Sets parameter based on motor nameplate	0~7200 [rpm]	1500 [rpm]	See 8.9
P17.11	Basic Control Function	[0] V/F [1] S/L Vector Control [2] CL Vector Control [3] Line Converter Control (AFE) [4] Line Active Power Filter	0~4	0	
P17.12	PWM @Carrier Frequency	Sets the carrier frequency.	1.00~10.00 [kHz]	3.00 [kHz]	See 8.9
P17.14	V/FCurve Pattern	[0] Linear Curve V/F [1] Multi-point Curve V/F [2] Square Curve V/F	0~3	0	See 8.9
P17.15	Torque Compensation	[0] Disabled [1] Enabled	0~1	0	See 8.9
P17.16	Torque Compensation Time	Sets torque compensation time	2~500 [ms]	500 [ms]	
P17.17	V/F Control Mode	[0] V/F Frequency Control [1] Slip Compensated Speed Control	0~1	0	
P17.18	Slip Compensation Time	Sets the slip compensation time.	10~1000 [ms]	200 [ms]	
P17.19	Stator Resistance Auto-Tuning Option	[0]Online [1]Offline	0~1	0	
P17.22	Delay Time @START	Sets the delay time at start.	0.00~100.00 [s]	0.00 [s]	See 8.9
P17.23	Min. Frequency	Sets the minimum frequency (valid only when running in V/F control mode).	0.00~300.00 [Hz]	0.00 [Hz]	

P17.24	Max. Frequency	Sets the maximum frequency (valid only when running in V/F control mode).	0.00~300.00 [Hz]	50.00 [Hz]	
P17.25	Max. Modulation Ratio	Sets the maximum modulation ratio.	0.0~120.0 [%]	100.0 [%]	
P17.26	V/F DC offset	Sets the V/F DC offset at start.	0.00~10.00 [%]	0.75 [%]	See 8.9
P17.27	Nominal Frequency Voltage	Sets the output voltage at nominal frequency.	0.0~200.0 [%]	100.0 [%]	See 8.9
P17.30	Square Curve Voltage Compensation @START	Sets the square curve voltage compensation at start.	0.0~100.0 [%]	0.0 [%]	See 8.9
P17.33	Number of V/F points	Sets the number of V/F points	0~6	2	See 8.9
P17.34	V/F point @F1		0.0~300.0 [Hz]	5.0 [Hz]	
P17.35	V/F point @V1		0.0~125.0 [%]	11.5 [%]	
P17.36	V/F point @F2		0.0~300.0 [Hz]	50.0 [Hz]	
P17.37	V/F point @V2		0.0~125.0 [%]	100.0 [%]	
P17.38	V/F point @F3		0.0~300.0 [Hz]	50.0 [Hz]	
P17.39	V/F point @V3		0.0~125.0 [%]	100.0 [%]	
P17.40	V/F point @F4		0.0~300.0 [Hz]	50.0 [Hz]	
P17.41	V/F point @V4		0.0~125.0 [%]	100.0 [%]	
P17.42	V/F point @F5		0.0~300.0 [Hz]	50.0 [Hz]	
P17.43	V/F point @V5		0.0~125.0 [%]	100.0 [%]	
P17.44	V/F point @F6		0.0~300.0 [Hz]	50.0 [Hz]	
P17.45	V/F point @V6		0.0~125.0 [%]	100.0 [%]	
P17.46	V/F Curve @FREE_BLOCK		0~300	0	
P17.47	Voltage_ADJ @FREE_BLOCK		0~300	0	
P17.48	Frequency_Adj_SRC	[0]DISABLE	0~3	0	

		[1] PID BLOCK 1 [2] PID BLOCK 2 [3] FREE BLOCK			
P17.49	Frequency_ADJ @FREE_BLOCK		0~300	0	
P17.50	START_DC_Braking @time	Sets the time of START_DC_Braking.	0.00~300.00 [s]	0.00 [s]	See 8.9
P17.51	START_DC_Braking @current	Sets the current of START_DC_Braking.	0.0~150.0 [%]	70.0 [%]	See 8.9
P17.52	START_DC_Braking @frequency	Sets the frequency of START_DC_Braking.	0.00~5.00 [Hz]	0.00 [Hz]	See 8.9
P17.54	STOP_DC_Braking @time	Sets the time of STOP_DC_Braking.	0.00~300.00 [s]	0.00 [s]	See 8.9
P17.55	STOP_DC_Braking @current	Sets the current of STOP_DC_Braking.	0.0~150.0 [%]	75.0 [%]	See 8.9
P17.56	STOP_DC_Braking @frequency	Sets the frequency of STOP_DC_Braking.	0.00~5.00 [Hz]	0.00 [Hz]	See 8.9
P17.59	Kp_OC_Protection	Sets OC_Protection ratio	0.0~1000.0 [%]	100.0 [%]	
P17.60	Ki_OC_Protection	Sets OC_Protection integral	0.0~1000.0 [%]	100.0 [%]	
P17.61	Kp_OV_Limiter	Sets OV_limiter ratio	0.0~1000.0 [%]	100.0 [%]	
P17.62	Ki_OV_Limiter	Sets OV_limiter integral	0.0~1000.0 [%]	100.0 [%]	
P17.64	V/F Stabilization @Gain	Sets the gain of V/F stabilization.	0.0~1000.0 [%]	100.0 [%]	See 8.9
P17.66	K_CL_Ctrl	Sets the ratio of current limit loop in V/F control mode.	0.0~1000.0 [%]	100.0 [%]	
P17.67	Start DC Brake Ratio	Sets start DC brake Ratio	0.0~1000.0 [%]	100.0 [%]	
P17.68	Start DC Brake Integral	Sets start DC brake integral	0.0~1000.0 [%]	100.0 [%]	
P17.69	Stop DC Brake Ratio	Sets stop DC brake Ratio	0.0~1000.0 [%]	100.0 [%]	
P17.70	Stop DC Brake Integral	Sets stop DC brake integral	0.0~1000.0 [%]	100.0 [%]	

7.18 Motor 3 Parameter V/F Set P18

Par. NO	Parameter Name	Description	Range	Default	Ref. Chapter
P18.0	Supply Voltage	Sets based on actual supply voltage	320~480 [V]	380 [V]	
P18.2	Nominal Power	Sets parameter based on motor nameplate	0.0~4000.0 [kW]	Model dependent [kW]	
P18.3	Nominal Voltage	Sets parameter based on motor nameplate	320~480 [V]	380 [V]	
P18.4	Nominal Current	Sets parameter based on motor nameplate	0.0~6500.0 [A]	Model dependent [A]	
P18.5	Nominal Frequency	Sets parameter based on motor nameplate	0.0~300.0 [Hz]	50.0 [Hz]	
P18.6	Nominal Speed	Sets parameter based on motor nameplate	0~6000 [rpm]	1465 [rpm]	
P18.7	Number of Poles	Sets parameter based on motor nameplate	2~12 [pole]	4 [pole]	See 8.9
P18.9	Motor Synchronous Speed	Sets parameter based on motor nameplate	0~7200 [rpm]	1500 [rpm]	See 8.9
P18.11	Basic Control Function	[0] V/F [1] S/L Vector Control [2] CL Vector Control [3] Line Converter Control (AFE) [4] Line Active Power Filter	0~4	0	
P18.12	PWM @Carrier Frequency	Sets the carrier frequency.	1.00~10.00 [kHz]	3.00 [kHz]	See 8.9
P18.14	V/F Curve Pattern	[0] Linear Curve V/F [1] Multi-point Curve V/F [2] Square Curve V/F	0~3	0	See 8.9
P18.15	Torque Compensation	[0] Disabled [1] Enabled	0~1	0	See 8.9
P18.16	Torque Compensation Time	Sets torque compensation time	2~500 [ms]	500 [ms]	
P18.17	V/F Control Mode	[0] V/F Frequency Control [1] Slip Compensated	0~1	0	

		Speed Control			
P18.18	Slip Compensation Time	Sets the slip compensation time.	10~1000 [ms]	200 [ms]	
P18.19	Stator Resistance Auto-Tuning Option	[0]Online [1]Offline	0~1	0	
P18.22	Delay Time @START	Sets the delay time at start.	0.00~100.00 [s]	0.00 [s]	See 8.9
P18.23	Min. Frequency	Sets the minimum frequency (valid only when running in V/F control mode).	0.00~300.00 [Hz]	0.00 [Hz]	
P18.24	Max. Frequency	Sets the maximum frequency (valid only when running in V/F control mode).	0.00~300.00 [Hz]	50.00 [Hz]	
P18.25	Max. Modulation Ratio	Sets the maximum modulation ratio.	0.0~120.0 [%]	100.0 [%]	
P18.26	V/F DC offset	Sets the V/F DC offset at start.	0.00~10.00 [%]	0.75 [%]	See 8.9
P18.27	Nominal Frequency Voltage	Sets the output voltage at nominal frequency.	0.0~200.0 [%]	100.0 [%]	See 8.9
P18.30	Square Curve Voltage Compensation @START	Sets the square curve voltage compensation at start.	0.0~100.0 [%]	0.0 [%]	See 8.9
P18.33	Number of V/F points	Sets the number of V/F points	0~6	2	See 8.9
P18.34	V/F point @F1		0.0~300.0 [Hz]	5.0 [Hz]	
P18.35	V/F point @V1		0.0~125.0 [%]	11.5 [%]	
P18.36	V/F point @F2		0.0~300.0 [Hz]	50.0 [Hz]	
P18.37	V/F point @V2		0.0~125.0 [%]	100.0 [%]	
P18.38	V/F point @F3		0.0~300.0 [Hz]	50.0 [Hz]	
P18.39	V/F point @V3		0.0~125.0 [%]	100.0 [%]	
P18.40	V/F point @F4		0.0~300.0 [Hz]	50.0 [Hz]	
P18.41	V/F point @V4		0.0~125.0 [%]	100.0 [%]	
P18.42	V/F point @F5		0.0~300.0	50.0	

			[Hz]	[Hz]	
P18.43	V/F point @V5		0.0~125.0 [%]	100.0 [%]	
P18.44	V/F point @F6		0.0~300.0 [Hz]	50.0 [Hz]	
P18.45	V/F point @V6		0.0~125.0 [%]	100.0 [%]	
P18.46	V/F Curve @FREE_BLOCK		0~300	0	
P18.47	Voltage_ADJ @FREE_BLOCK		0~300	0	
P18.48	Frequency_Adj_SRC	[0]DISABLE [1] PID BLOCK 1 [2] PID BLOCK 2 [3] FREE BLOCK	0~3	0	
P18.49	Frequency_ADJ @FREE_BLOCK		0~300	0	
P18.50	START_DC_Braking @time	Sets the time of START_DC_Braking.	0.00~300.00 [s]	0.00 [s]	See 8.9
P18.51	START_DC_Braking @current	Sets the current of START_DC_Braking.	0.0~150.0 [%]	70.0 [%]	See 8.9
P18.52	START_DC_Braking @frequency	Sets the frequency of START_DC_Braking.	0.00~5.00 [Hz]	0.00 [Hz]	See 8.9
P18.54	STOP_DC_Braking @time	Sets the time of STOP_DC_Braking.	0.00~300.00 [s]	0.00 [s]	See 8.9
P18.55	STOP_DC_Braking @current	Sets the current of STOP_DC_Braking.	0.0~150.0 [%]	75.0 [%]	See 8.9
P18.56	STOP_DC_Braking @frequency	Sets the frequency of STOP_DC_Braking.	0.00~5.00 [Hz]	0.00 [Hz]	See 8.9
P18.59	OC_Protection Ratio Gain	Sets OC_Protection ratio	0.0~1000.0 [%]	100.0 [%]	
P18.60	OC_Protection Integral Gain	Sets OC_Protection integral	0.0~1000.0 [%]	100.0 [%]	
P18.61	OV_Limit Ratio	Sets OV_Limit ratio	0.0~1000.0 [%]	100.0 [%]	
P18.62	OV_Limit Integral	Sets OV_Limit integral	0.0~1000.0 [%]	100.0 [%]	
P18.64	V/F Stabilization @Gain	Sets the gain of V/F stabilization.	0.0~1000.0 [%]	100.0 [%]	See 8.9
P18.66	Current Limit Ratio Gain	Sets the ratio of current limit loop in V/F control mode.	0.0~1000.0 [%]	100.0 [%]	

P18.67	Start DC Brake Ratio	Sets start DC brake Ratio	0.0~1000.0 [%]	100.0 [%]	
P18.68	Start DC Brake Integral	Sets start DC brake integral	0.0~1000.0 [%]	100.0 [%]	
P18.69	Stop DC Brake Ratio	Sets stop DC brake Ratio	0.0~1000.0 [%]	100.0 [%]	
P18.70	Stop DC Brake Integral	Sets stop DC brake integral	0.0~1000.0 [%]	100.0 [%]	

7.19 Motor 4 Parameter V/F Set P19

Par. NO	Parameter Name	Description	Range	Default	Ref. Chapter
P19.0	Supply Voltage	Sets based on actual supply voltage	320~480 [V]	380 [V]	
P19.2	Nominal Power	Sets parameter based on motor nameplate	0.0~4000.0 [kW]	Model dependent [kW]	
P19.3	Nominal Voltage	Sets parameter based on motor nameplate	320~480 [V]	380 [V]	
P19.4	Nominal Current	Sets parameter based on motor nameplate	0.0~6500.0 [A]	Model dependent [A]	
P19.5	Nominal Frequency	Sets parameter based on motor nameplate	0.0~300.0 [Hz]	50.0 [Hz]	
P19.6	Nominal Speed	Sets parameter based on motor nameplate	0~6000 [rpm]	1465 [rpm]	
P19.7	Number of Poles	Sets parameter based on motor nameplate	2~12 [pole]	4 [pole]	See 8.9
P19.9	Motor Synchronous Speed	Sets parameter based on motor nameplate	0~7200 [rpm]	1500 [rpm]	See 8.9
P19.11	Basic Control Function	[0] V/F [1] S/L Vector Control [2] CL Vector Control [3] Line Converter Control (AFE) [4] Line Active Power Filter	0~4	0	
P19.12	PWM @Carrier Frequency	Sets the carrier frequency.	1.00~10.00 [kHz]	3.00 [kHz]	See 8.9

P19.14	V/F Curve Pattern	[0] Linear Curve V/F [1] Multi-point Curve V/F [2] Square Curve V/F	0~3	0	See 8.9
P19.15	Torque Compensation	[0] Disabled [1] Enabled	0~1	0	See 8.9
P19.16	Torque Compensation Time	Sets the torque compensation time	2~500 [ms]	500 [ms]	
P19.17	V/F Control Mode	[0] V/F Frequency Control [1] Slip Compensated Speed Control	0~1	0	
P19.18	Slip Compensation Time	Sets the slip compensation time.	10~1000 [ms]	200 [ms]	
P19.19	Stator Resistance Auto-Tuning Option	[0] Online [1] Offline	0~1	0	
P19.22	Delay Time @START	Sets the delay time at start.	0.00~100.00 [s]	0.00 [s]	See 8.9
P19.23	Min. Frequency	Sets the minimum frequency (valid only when running in V/F control mode).	0.00~300.00 [Hz]	0.00 [Hz]	
P19.24	Max. Frequency	Sets the maximum frequency (valid only when running in V/F control mode).	0.00~300.00 [Hz]	50.00 [Hz]	
P19.25	Max. Modulation Ratio	Sets the maximum modulation ratio.	0.0~120.0 [%]	100.0 [%]	
P19.26	V/F DC offset	Sets the V/F DC offset at start.	0.00~10.00 [%]	0.75 [%]	See 8.9
P19.27	Nominal Frequency Voltage	Sets the output voltage at nominal frequency.	0.0~200.0 [%]	100.0 [%]	See 8.9
P19.30	Square Curve Voltage Compensation @START	Sets the square curve voltage compensation at start.	0.0~100.0 [%]	0.0 [%]	See 8.9
P19.33	Number of V/F points	Sets the number of V/F points	0~6	2	See 8.9
P19.34	V/F point @F1		0.0~300.0 [Hz]	5.0 [Hz]	
P19.35	V/F point @V1		0.0~125.0 [%]	11.5 [%]	
P19.36	V/F point @F2		0.0~300.0 [Hz]	50.0 [Hz]	
P19.37	V/F point @V2		0.0~125.0	100.0	

			[%]	[%]	
P19.38	V/F point @F3		0.0~300.0 [Hz]	50.0 [Hz]	
P19.39	V/F point @V3		0.0~125.0 [%]	100.0 [%]	
P19.40	V/F point @F4		0.0~300.0 [Hz]	50.0 [Hz]	
P19.41	V/F point @V4		0.0~125.0 [%]	100.0 [%]	
P19.42	V/F point @F5		0.0~300.0 [Hz]	50.0 [Hz]	
P19.43	V/F point @V5		0.0~125.0 [%]	100.0 [%]	
P19.44	V/F point @F6		0.0~300.0 [Hz]	50.0 [Hz]	
P19.45	V/F point @V6		0.0~125.0 [%]	100.0 [%]	
P19.46	V/F Curve @FREE_BLOCK		0~300	0	
P19.47	Voltage_ADJ @FREE_BLOCK		0~300	0	
P19.48	Frequency_Adj_SRC	[0] DISABLE [1] PID BLOCK 1 [2] PID BLOCK 2 [3] FREE BLOCK	0~3	0	
P19.49	Frequency_ADJ @FREE_BLOCK		0~300	0	
P19.50	START_DC_Braking @time	Sets the time of START_DC_Braking.	0.00~300.00 [s]	0.00 [s]	See 8.9
P19.51	START_DC_Braking @current	Sets the current of START_DC_Braking.	0.0~150.0 [%]	70.0 [%]	See 8.9
P19.52	START_DC_Braking @frequency	Sets the frequency of START_DC_Braking.	0.00~5.00 [Hz]	0.00 [Hz]	See 8.9
P19.54	STOP_DC_Braking @time	Sets the time of STOP_DC_Braking.	0.00~300.00 [s]	0.00 [s]	See 8.9
P19.55	STOP_DC_Braking @current	Sets the current of STOP_DC_Braking.	0.0~150.0 [%]	75.0 [%]	See 8.9
P19.56	STOP_DC_Braking @frequency	Sets the frequency of STOP_DC_Braking.	0.00~5.00 [Hz]	0.00 [Hz]	See 8.9
P19.59	Kp_OC_Protection	Sets OC_Protection ratio	0.0~1000.0 [%]	100.0 [%]	
P19.60	Ki_OC_Protection	Sets OC_Protection integral	0.0~1000.0 [%]	100.0 [%]	

P19.61	Kp_OV_Limiter	Sets OV_Limiter ratio	0.0~1000.0 [%]	100.0 [%]	
P19.62	Ki_OV_Limiter	Sets OV_Limiter integral	0.0~1000.0 [%]	100.0 [%]	
P19.64	V/F Stabilization @Gain	Sets the gain of V/F stabilization.	0.0~1000.0 [%]	100.0 [%]	See 8.9
P19.66	K_CL_Ctrl	Sets the ratio of current limit loop in V/F control mode.	0.0~1000.0 [%]	100.0 [%]	
P19.67	Start DC Brake Ratio	Sets start DC brake Ratio	0.0~1000.0 [%]	100.0 [%]	
P19.68	Start DC Brake Integral	Sets start DC brake integral	0.0~1000.0 [%]	100.0 [%]	
P19.69	Stop DC Brake Ratio	Sets stop DC brake Ratio	0.0~1000.0 [%]	100.0 [%]	
P19.70	Stop DC Brake Integral	Sets stop DC brake integral	0.0~1000.0 [%]	100.0 [%]	

7.20 Motor 1 Vector Control Set P20

Par. NO	Parameter Name	Description	Range	Default	Ref. Chapter
P20.0	Dynamic Torque Control	[0] Disabled [1] Enabled	0~1	0	See 8.10
P20.1	Torque_Set Source	[0] Speed_Ctrl [1] AI 1 [2] AI 2 [3] Local Operator [4] Fixed Set:determined by the value of P20.3 [5] Profibus DP [6] MODBUS [7] FREE BLOCK	0~7	0	See 8.10
P20.2	Torque_Set Source @REV_DIR	Same as P20.1	0~7	0	
P20.3	Trq_Set @Fixed_Value	Sets the fixed value of torque.	-300.0~ 300.0 [%]	0.0 [%]	See 8.10
P20.4	Trq_Set @FREE_BLOCK		0~300	0	
P20.5	Torque_Set Filter Time		0~1000 [ms]	0 [ms]	
P20.6	Torque_Set Weight		0.0~200.0	100.0	See

			[%]	[%]	8.10
P20.7	Torque Limit Source	[0] Internal Limit [1] Fixed SET:determined by the value of P20.3 and P20.9 [2] AI 1 [3] AI 2 [4] LOCAL_SET [5] DP Communiation [6] MODBUS [7] FREE BLOCK	0~7	0	See 8.10
P20.8	Torque Limit @Fwd Direction	This parameter is valid when P20.7 being selected [1].	0.0~300.0 [%]	200.0 [%]	See 8.10
P20.9	Torque Limit @Rev Direction	This parameter is valid when P20.7 being selected [1].	0.0~300.0 [%]	200.0 [%]	See 8.10
P20.10	Torque Limit @FREE_BLOCK		0~300	0	
P20.11	Torque_Limit Filter Time		0~1000 [ms]	0 [ms]	
P20.12	Kp_2x @Spd_Ctrl	Sets the proportional gain for high speed control.	0.0~300.0 [%]	100.0 [%]	
P20.14	Encoder Pulses numbers	Sets the pulses number of motor per Rev	0~60000	1024	
P20.15	Encoder Phase Sequence Reverse	0]Disabled [1]Enabled	0~1	0	See 8.10
P20.16	Max. Speed	Sets the maximum speed when in forward (valid only when running in Vector control mode).	0.0~300.0 [%]	100.0 [%]	
P20.17	Max. Reverse Speed	Sets the maximum speed when in reverse (valid only when running in Vector control mode).	0.0~300.0 [%]	100.0 [%]	
P20.18	Min. Speed	Sets the minimum speed when in forward (valid only when running in Vector control mode).	0.0~300.0 [%]	0.0 [%]	
P20.19	Min. Reverse Speed	Sets the minimum speed when in reverse (valid only when running in Vector control mode).	0.0~300.0 [%]	0.0 [%]	

P20.20	Adjustable Speed Limit Function	[0]Disabled [1]Enabled	0~1	0	
P20.21	Adjustable Speed Limit Curve	[0]PARABOLIC [1]LINEAR	0~1	0	
P20.22	Speed Limit I @Min_Load	Valid only when running in constant power control mode.	0.0~300.0 [%]	160.0 [%]	
P20.23	Min_Load @Spd_Lmt_I	Valid only when running in constant power control mode.	0.0~200.0 [%]	20.0 [%]	
P20.24	Speed Limit II @Max_Load	Valid only when running in constant power control mode.	0.0~300.0 [%]	100.0 [%]	
P20.25	Max_Load @Spd_Lmt_II	Valid only when running in constant power control mode.	0.0~200.0 [%]	100.0 [%]	
P20.26	Position Loop Gain	Position Loop Gain	0.0~1000.0 [%]	0.0 [%]	See 8.10
P20.27	Position Loop Speed Compensation	Position loop output limit value, corresponding Max. speed regulating variable	0.00~15.00 [%]	2.00 [%]	See 8.10
P20.28	Speed Limit @Torque_Control	[0]Max. Speed Set:limited by the value of P20.16 and P20.17 [1]Ramp Function Input [2]Ramp Function Output [3]PROFIBUS	0~3	0	
P20.30	Speed Offset Source (For torque control mode)	[0]Fixed Offset: the speed offset determined by the value of P20.31 and P20.32 [1]AI 1 [2]AI 2 [3]Local SET	0~3	0	
P20.31	FWD Speed_Offset	Sets FWD speed offset value	0.0~100.0 [%]	5.0 [%]	
P20.32	REV Speed_Offset	Sets REV speed offset value	0.0~100.0 [%]	5.0 [%]	
P20.34	Synchronal Compensation Enabled	[0]Disabled [1]Enabled	0~1	0	See 8.10
P20.35	Field Hold Time	Field hold time after stop	0.0~100.0 [s]	0.0 [s]	

P20.36	Start Field Current	Sets start field current value	50.0~150.0 [%]	110.0 [%]	
P20.37	Start Base Field	Sets the start base field	0.0~150.0 [%]	100.0 [%]	See 8.10
P20.38	Base Field END_Speed	Sets the end speed for base field.	0.0~100.0 [%]	25.0 [%]	See 8.10
P20.39	Base Field	Sets the base field.	0.0~120.0 [%]	100.0 [%]	See 8.10
P20.40	Base Field Start Speed	Sets the start speed for base field	0.0~150.0 [%]	100.0 [%]	See 8.10
P20.41	Max. Field	Sets the maximum field.	0.0~150.0 [%]	135.0 [%]	
P20.42	LOAD DETECTION	[0]Disabled [1]Enabled	0~1	1	
P20.43	Load Detection Time	Sets the time for load detection.	25~1000 [ms]	75 [ms]	
P20.44	Weight Detection Time	Sets the time for weight detection.	25~1000 [ms]	250 [ms]	
P20.45	FWD_Torque @Zero Weight	Valid only when running in constant power control mode.	0.0~100.0 [%]	22.0 [%]	
P20.46	REV_Torque @Zero Weight	Valid only when running in constant power control mode.	0.0~100.0 [%]	18.0 [%]	
P20.47	FWD_Torque @Weight under Test	Valid only when running in constant power control mode.	0.0~200.0 [%]	92.0 [%]	
P20.48	REV_Torque @Weight under Test	Valid only when running in constant power control mode.	0.0~200.0 [%]	87.0 [%]	
P20.49	Weight under Test	Valid only when running in constant power control mode.	0.0~150.0 [%]	100.0 [%]	
P20.51	Kp @OV_SUPPRESSION_Ctrl	Sets the proportional gain for overvoltage suppression.	0.0~1000.0 [%]	100.0 [%]	
P20.52	Ki @OV_SUPPRESSION_Ctrl	Sets the integral gain for overvoltage suppression.	0.0~1000.0 [%]	100.0 [%]	
P20.53	Kp @field_ctrl	Sets the proportional gain for field control.	0.0~1000.0 [%]	100.0 [%]	
P20.54	Ki @field_ctrl	Sets the integral gain for field control.	0.0~1000.0 [%]	100.0 [%]	

P20.55	K @Spd_Ctrl	Sets the proportional gain for speed control.	0.0~1000.0 [%]	100.0 [%]	See 8.10
P20.56	Ki @field_ctrl	Sets the integral gain for field control.	0.0~1000.0 [%]	100.0 [%]	See 8.10
P20.57	Field Discharge Enabled	[0]Disabled [1]Enabled	0~1	0	See 8.10
P20.58	Field Discharge Max. Current	Sets the Max. current value for field discharge	0.0~125.0 [%]	100.0 [%]	See 8.10
P20.59	Excitation after Field Discharge	Sets excitation value after field discharge stop	1.0~25.0 [%]	2.5 [%]	See 8.10
P20.60	DR00P Control Gain	DR00P is invalid when 0 is set	0.0~100.0 [%]	0.0 [%]	See 8.10
P20.61	DR00P Control Filter Time	Adjust R00P control response. Increase the value when vibrating and surging.	30~2000 [ms]	50 [ms]	See 8.10
P20.62	Kp @current_ctrl	Sets the proportional gain for current control.	0.0~1000.0 [%]	100.0 [%]	See 8.10
P20.63	Ki @current_ctrl	Sets the integral gain for current control.	0.0~1000.0 [%]	100.0 [%]	See 8.10
P20.64	Master_slave gain	Synchronization control gain	0.0~100.0 [%]	0	See 8.10
P20.65	MS Filter Time	Synchronization control filter time	30~2000ms	50	
P20.98	Jm @Acc_time	Sets the load inertia. (in units of time)	0.01~300.00 [s]	0.75 [s]	
P20.99	Bm @Friction Loss Factor	Sets the friction loss factor.	0.00~10.00 [%]	0.00 [%]	

7.21 Motor 2 Vector Control Set P21

Par. NO	Parameter Name	Description	Range	Default	Ref. Chapter
P21.0	Dynamic Torque Control	[0] Disabled [1] Enabled	0~1	0	See 8.10
P21.1	Torque_Set Source	[0] Speed_Ctrl [1] AI 1 [2] AI 2 [3] Local Operator [4] Fixed Set:determined by the value of P21.3 [5] Profibus DP [6] MODBUS [7] FREE BLOCK	0~7	0	See 8.10
P21.2	Torque_Set Source @REV_DIR	Same as P21.1	0~7	0	
P21.3	Trq_Set @Fixed_Value	Sets the fixed value of torque.	-300.0~ 300.0 [%]	0.0 [%]	See 8.10
P21.4	Trq_Set @FREE_BLOCK		0~300	0	
P21.5	Torque_Set Filter Time		0~1000 [ms]	0 [ms]	
P21.6	Torque_Set Weight		0.0~200.0 [%]	100.0 [%]	See 8.10
P21.7	Torque Limit Source	[0] Internal Limit [1] Fixed SET: determined by the value of P21.3 and P21.9 [2] AI 1 [3] AI 2 [4] LOCAL_SET [5]Profibus DP [6] MODBUS [7] FREE BLOCK	0~7	0	See 8.10
P21.8	Torque Limit @Fwd Direction	This parameter is valid when P21.7 being selected [1].	0.0~300.0 [%]	200.0 [%]	See 8.10
P21.9	Torque Limit @Rev Direction	This parameter is valid when P21.7 being selected [1].	0.0~300.0 [%]	200.0 [%]	See 8.10
P21.10	Torque Limit @FREE_BLOCK		0~300	0	

P21.11	Torque_Limit Filter Time		0~1000 [ms]	0 [ms]	
P21.12	Kp_2x @Spd_Ctrl	Sets the proportional gain for high speed control.	0.0~300.0 [%]	100.0 [%]	
P21.14	Encoder Pulses numbers	Sets the pulses number of motor per Rev	0~60000	1024	
P21.15	Encoder Phase Sequence Reverse	[0]Disabled [1]Enabled	0~1	0	See 8.10
P21.16	Max. Speed	Sets the maximum speed when in forward (valid only when running in Vector control mode).	0.0~300.0 [%]	100.0 [%]	
P21.17	Max. Reverse Speed	Sets the maximum speed when in reverse (valid only when running in Vector control mode).	0.0~300.0 [%]	100.0 [%]	
P21.18	Min. Speed	Sets the minimum speed when in forward (valid only when running in Vector control mode).	0.0~300.0 [%]	0.0 [%]	
P21.19	Min. Reverse Speed	Sets the minimum speed when in reverse (valid only when running in Vector control mode).	0.0~300.0 [%]	0.0 [%]	
P21.20	Constant Power Speed Limit Enabled	[0]Disabled [1]Enabled	0~1	0	
P21.21	Constant Power Speed Limit Curve	[0]PARABOLIC [1]LINEAR	0~1	0	
P21.22	Speed Limit I @Min_Load	Valid only when running in constant power control mode.	0.0~300.0 [%]	160.0 [%]	
P21.23	Min_Load @Spd_Lmt_I	Valid only when running in constant power control mode.	0.0~200.0 [%]	20.0 [%]	
P21.24	Speed Limit II @Max_Load	Valid only when running in constant power control mode.	0.0~300.0 [%]	100.0 [%]	
P21.25	Max_Load @Spd_Lmt_II	Valid only when running in constant power control mode.	0.0~200.0 [%]	100.0 [%]	
P21.26	Position Loop Gain	Sets position loop gain.	0.0~1000.0	0.0	See

			[%]	[%]	8.10
P21.27	Position Loop Speed Compensation	Position loop output limit value, corresponding Max. Speed regulating variable.	0.00~15.00 [%]	2.00 [%]	See 8.10
P21.28	Speed Limit @Torque_Control	[0]Max. Speed Set: limited by the value of P21.16 and P21.17 [1]Ramp Function Input [2]Ramp Function Output [3]Profibus DP	0~3	0	
P21.30	Speed Offset Source (For torque control mode)	[0]Fixed Offset: the speed offset determined by the value of P21.31 and P21.32 [1]AI 1 [2]AI 2 [3]Local SET	0~3	0	
P21.31	FWD Speed_Offset	Sets forward speed offset.	0.0~100.0 [%]	5.0 [%]	
P21.32	REV Speed_Offset	Sets reverse speed offset.	0.0~100.0 [%]	5.0 [%]	
P21.34	Synchronal Compensation Enabled	[0]Disabled [1]Enabled	0~1	0	See 8.10
P21.35	Field Hold Time	Sets field hold time after stop.	0.0~100.0 [s]	0.0 [s]	
P21.36	Start Field Current	Sets start field current value.	50.0~150.0 [%]	110.0 [%]	
P21.37	Base Field	Sets the base field.	0.0~150.0 [%]	100.0 [%]	See 8.10
P21.38	Base Field END_Speed	Sets the end speed for base field.	0.0~100.0 [%]	25.0 [%]	See 8.10
P21.39	Top Field	Sets the top field.	0.0~120.0 [%]	100.0 [%]	See 8.10
P21.40	Top Field START_Speed	Sets the start speed for top field.	0.0~150.0 [%]	100.0 [%]	See 8.10
P21.41	Max. Field	Sets the maximum field.	0.0~150.0 [%]	135.0 [%]	
P21.42	Torque Detection	[0]Disabled [1]Enabled	0~1	1	
P21.43	Torque Detection Time	Sets torque detection ti	25~1000 [ms]	75 [ms]	

		me.			
P21.44	Load Detection Time	Sets the time for weight detection. (Valid only when running in constant power control mode.)	25~1000 [ms]	250 [ms]	
P21.45	FWD_Torque @Zero Weight	Valid only when running in constant power control mode. (Weight)	0.0~100.0 [%]	22.0 [%]	
P21.46	REV_Torque @Zero Weight	Valid only when running in constant power control mode.	0.0~100.0 [%]	18.0 [%]	
P21.47	FWD_Torque @Weight under Test	Valid only when running in constant power control mode.	0.0~200.0 [%]	92.0 [%]	
P21.48	REV_Torque @Weight under Test	Valid only when running in constant power control mode.	0.0~200.0 [%]	87.0 [%]	
P21.49	Weight under Test	Valid only when running in constant power control mode.	0.0~150.0 [%]	100.0 [%]	
P21.51	Kp @OV_SUPPRESSION_Ctrl	Sets the proportional gain for overvoltage suppression.	0.0~1000.0 [%]	100.0 [%]	
P21.52	Ki @OV_SUPPRESSION_Ctrl	Sets the integral gain for overvoltage suppression.	0.0~1000.0 [%]	100.0 [%]	
P21.53	Kp @field_ctrl	Sets the proportional gain for field control.	0.0~1000.0 [%]	100.0 [%]	
P21.54	Ki @field_ctrl	Sets the integral gain for field control.	0.0~1000.0 [%]	100.0 [%]	
P21.55	K @Spd_Ctrl	Sets the proportional gain for speed control.	0.0~1000.0 [%]	100.0 [%]	See 8.10
P21.56	K_Weight @Brake_Ctrl	Sets the gain for brake control when in forward.	0.0~1000.0 [%]	100.0 [%]	See 8.10
P21.57	Field Discharge Enabled	[0]Disabled [1]Enabled	0~1	0	See 8.10
P21.58	Field Discharge Max. Current	Sets the Max. current value for field discharge	0.0~125.0 [%]	100.0 [%]	See 8.10
P21.59	Excitation after Field Discharge	Sets excitation value after field discharge stop	1.0~25.0 [%]	2.5 [%]	See 8.10
P21.60	DROOP Control Gain	DROOP is invalid when 0 is	0.0~100.0 [%]	0.0 [%]	See 8.10

		set			
P21.61	DROOP Control Filter Time	Adjust ROOP control response. Increase the value when vibrating and surging.	30~2000 [ms]	50 [ms]	See 8.10
P21.62	Kp @current_ctrl	Sets the proportional gain for current control.	0.0~1000.0 [%]	100.0 [%]	See 8.10
P21.63	Ki @current_ctrl	Sets the integral gain for current control.	0.0~1000.0 [%]	100.0 [%]	See 8.10
P21.64	Master_slave gain	Synchronization control gain	0.0~100.0 [%]	0	See 8.10
P21.65	MS Filter Time	Synchronization control filter time	30~2000ms	50	
P21.98	Jm @Acc_time	Sets the load inertia. (in units of time)	0.01~300.00 [s]	0.75 [s]	
P21.99	Bm @Friction Loss Factor	Sets the friction loss factor.	0.00~10.00 [%]	0.00 [%]	

7.22 Motor 3 Vector Control Set P22

Par. NO	Parameter Name	Description	Range	Default	Ref. Chapter
P22.0	Dynamic Torque Control	[0] Disabled [1] Enabled	0~1	0	See 8.10
P22.1	Torque_Set Source	[0] Speed_Ctrl [1] AI 1 [2] AI 2 [3] Local Operator [4] Fixed Set:determined by the value of P22.3 [5] Profibus DP [6] MODBUS [7] FREE BLOCK	0~7	0	See 8.10
P22.2	Torque_Set Source @REV_DIR	Same as P22.1	0~7	0	
P22.3	Trq_Set @Fixed_Value	Sets the fixed value of torque.	-300.0~ 300.0 [%]	0.0 [%]	See 8.10
P22.4	Trq_Set @FREE_BLOCK		0~300	0	
P22.5	Torque_Set Filter Time		0~1000 [ms]	0 [ms]	
P22.6	Torque_Set Weight		0.0~200.0	100.0	See

			[%]	[%]	8.10
P22.7	Torque Limit Source	[0] Internal Limit [1] Fixed SET: determined by the value of P21.3 and P21.9 [2] AI 1 [3] AI 2 [4] LOCAL_SET [5] Profibus DP [6] MODBUS [7] FREE BLOCK	0~7	0	See 8.10
P22.8	Torque Limit @Fwd Direction	This parameter is valid when P22.7 being selected [1].	0.0~300.0 [%]	200.0 [%]	See 8.10
P22.9	Torque Limit @Rev Direction	This parameter is valid when P22.7 being selected [1].	0.0~300.0 [%]	200.0 [%]	See 8.10
P22.10	Torque Limit @FREE_BLOCK		0~300	0	
P22.11	Torque_Limit Filter Time		0~1000 [ms]	0 [ms]	
P22.12	Kp_2x @Spd_Ctrl	Sets the proportional gain for high speed control.	0.0~300.0 [%]	100.0 [%]	
P22.14	Encoder Pulses numbers	Sets the pulses number of motor per Rev	0~60000	1024	
P22.15	Encoder Phase Sequence Reverse	[0] Disabled [1] Enabled	0~1	0	See 8.10
P22.16	Max. Speed	Sets the maximum speed when in forward (valid only when running in Vector control mode).	0.0~300.0 [%]	100.0 [%]	
P22.17	Max. Reverse Speed	Sets the maximum speed when in reverse (valid only when running in Vector control mode).	0.0~300.0 [%]	100.0 [%]	
P22.18	Min. Speed	Sets the minimum speed when in forward (valid only when running in Vector control mode).	0.0~300.0 [%]	0.0 [%]	
P22.19	Min. Reverse Speed	Sets the minimum speed when in reverse (valid only when running in	0.0~300.0 [%]	0.0 [%]	

		Vector control mode).			
P22.20	Constant Power Speed Limit Enabled	[0]Disabled [1]Enabled	0~1	0	
P22.21	Constant Power Speed Limit Curve	[0]PARABOLIC [1]LINEAR	0~1	0	
P22.22	Speed Limit I @Min_Load	Valid only when running in constant power control mode.	0.0~300.0 [%]	160.0 [%]	
P22.23	Min_Load @Spd_Lmt_I	Valid only when running in constant power control mode.	0.0~200.0 [%]	20.0 [%]	
P22.24	Speed Limit II @Max_Load	Valid only when running in constant power control mode.	0.0~300.0 [%]	100.0 [%]	
P22.25	Max_Load @Spd_Lmt_II	Valid only when running in constant power control mode.	0.0~200.0 [%]	100.0 [%]	
P22.26	Position Loop Gain	Sets position loop gain.	0.0~1000.0 [%]	0.0 [%]	See 8.10
P22.27	Position Loop Speed Compensation	Position loop output limit value, corresponding Max. Speed regulating variable.	0.00~15.00 [%]	2.00 [%]	See 8.10
P22.28	Speed Limit @Torque_Control	[0]Max. Speed Set: limited by the value of P22.16 and P22.17 [1]Ramp Function Input [2]Ramp Function Output [3]Profibus DP	0~3	0	
P22.30	Speed Offset Source (For torque control mode)	[0]Fixed Offset: the speed offset determined by the value of P22.31 and P22.32 [1]AI 1 [2]AI 2 [3]Local SET	0~3	0	
P22.31	FWD Speed_Offset	Sets forward speed offset.	0.0~100.0 [%]	5.0 [%]	
P22.32	REV Speed_Offset	Sets reverse speed offset.	0.0~100.0 [%]	5.0 [%]	
P22.34	Synchronal Compensation	[0]Disabled	0~1	0	See

	Enabled	[1]Enabled			8.10
P22.35	Field Hold Time	Sets field hold time after stop.	0.0~100.0 [s]	0.0 [s]	
P22.36	Start Field Current	Sets start field current value.	50.0~150.0 [%]	110.0 [%]	
P22.37	Base Field	Sets the base field.	0.0~150.0 [%]	100.0 [%]	See 8.10
P22.38	Base Field END_Speed	Sets the end speed for base field.	0.0~100.0 [%]	25.0 [%]	See 8.10
P22.39	Top Field	Sets the top field.	0.0~120.0 [%]	100.0 [%]	See 8.10
P22.40	Top Field START_Speed	Sets the start speed for top field.	0.0~150.0 [%]	100.0 [%]	See 8.10
P22.41	Max. Field	Sets the maximum field.	0.0~150.0 [%]	135.0 [%]	
P22.42	Torque Detection	[0]Disabled [1]Enabled	0~1	1	
P22.43	Torque Detection Time	Sets torque detection time.	25~1000 [ms]	75 [ms]	
P22.44	Load Detection Time	Sets the time for weight detection. (Valid only when running in constant power control mode.)	25~1000 [ms]	250 [ms]	
P22.45	FWD_Torque @Zero Weight	Valid only when running in constant power control mode. (Weight)	0.0~100.0 [%]	22.0 [%]	
P22.46	REV_Torque @Zero Weight	Valid only when running in constant power control mode.	0.0~100.0 [%]	18.0 [%]	
P22.47	FWD_Torque @Weight under Test	Valid only when running in constant power control mode.	0.0~200.0 [%]	92.0 [%]	
P22.48	REV_Torque @Weight under Test	Valid only when running in constant power control mode.	0.0~200.0 [%]	87.0 [%]	
P22.49	Weight under Test	Valid only when running in constant power control mode.	0.0~150.0 [%]	100.0 [%]	
P22.51	Kp @OV_SUPPRESSION_Ctrl	Sets the proportional gain for overvoltage suppression.	0.0~1000.0 [%]	100.0 [%]	

P22.52	Ki @OV_SUPPRESSION_Ctrl	Sets the integral gain for overvoltage suppression.	0.0~1000.0 [%]	100.0 [%]	
P22.53	Kp @field_ctrl	Sets the proportional gain for field control.	0.0~1000.0 [%]	100.0 [%]	
P22.54	Ki @field_ctrl	Sets the integral gain for field control.	0.0~1000.0 [%]	100.0 [%]	
P22.55	K @Spd_Ctrl	Sets the proportional gain for speed control.	0.0~1000.0 [%]	100.0 [%]	See 8.10
P22.56	K_Weight @Brake_Ctrl	Sets the gain for brake control when in forward.	0.0~1000.0 [%]	100.0 [%]	See 8.10
P22.57	Field Discharge Enabled	[0]Disabled [1]Enabled	0~1	0	See 8.10
P22.58	Field Discharge Max. Current	Sets the Max. current value for field discharge	0.0~125.0 [%]	100.0 [%]	See 8.10
P22.59	Excitation after Field Discharge	Sets excitation value after field discharge stop	1.0~25.0 [%]	2.5 [%]	See 8.10
P22.60	DROOP Control Gain	DROOP is invalid when 0 is set	0.0~100.0 [%]	0.0 [%]	See 8.10
P22.61	DROOP Control Filter Time	Adjust ROOP control response. Increase the value when vibrating and surging.	30~2000 [ms]	50 [ms]	See 8.10
P22.62	Kp @current_ctrl	Sets the proportional gain for current control.	0.0~1000.0 [%]	100.0 [%]	See 8.10
P22.63	Ki @current_ctrl	Sets the integral gain for current control.	0.0~1000.0 [%]	100.0 [%]	See 8.10
P22.64	Master_slave gain	Synchronization control gain	0.0~100.0 [%]	0	See 8.10
P22.65	MS Filter Time	Synchronization control filter time	30~2000ms	50	
P22.98	Jm @Acc_time	Sets the load inertia. (in units of time)	0.01~300.00 [s]	0.75 [s]	
P22.99	Bm @Friction Loss Factor	Sets the friction loss factor.	0.00~10.00 [%]	0.00 [%]	

7.23 Motor 4 Vector Control Set P23

Par. NO	Parameter Name	Description	Range	Default	Ref. Chapter
P23.0	Dynamic Torque Control	[0] Disabled [1] Enabled	0~1	0	See 8.10
P23.1	Torque_Set Source	[0] Speed_Ctrl [1] AI 1 [2] AI 2 [3] Local Operator [4] Fixed Set:determined by the value of P23.3 [5] Profibus DP [6] MODBUS [7] FREE BLOCK	0~7	0	See 8.10
P23.2	Torque_Set Source @REV_DIR	Same as P23.1	0~7	0	
P23.3	Trq_Set @Fixed_Value	Sets the fixed value of torque.	-300.0~ 300.0 [%]	0.0 [%]	See 8.10
P23.4	Trq_Set @FREE_BLOCK		0~300	0	
P23.5	Torque_Set Filter Time		0~1000 [ms]	0 [ms]	
P23.6	Torque_Set Weight		0.0~200.0 [%]	100.0 [%]	See 8.10
P23.7	Torque Limit Source	[0] Internal Limit [1] Fixed SET; determined by the value of P23.3 and P21.9 [2] AI 1 [3] AI 2 [4] LOCAL_SET [5] Profibus DP [6] MODBUS [7] FREE BLOCK	0~7	0	See 8.10
P23.8	Torque Limit @Fwd Direction	This parameter is valid when P23.7 being selected [1].	0.0~300.0 [%]	200.0 [%]	See 8.10
P23.9	Torque Limit @Rev Direction	This parameter is valid when P23.7 being selected [1].	0.0~300.0 [%]	200.0 [%]	See 8.10
P23.10	Torque Limit @FREE_BLOCK		0~300	0	

P23.11	Torque_Limit Filter Time		0~1000 [ms]	0 [ms]	
P23.12	Kp_2x @Spd_Ctrl	Sets the proportional gain for high speed control.	0.0~300.0 [%]	100.0 [%]	
P23.14	Encoder Pulses numbers	Sets the pulses number of motor per Rev	0~60000	1024	
P23.15	Encoder Phase Sequence Reverse	[0]Disabled [1]Enabled	0~1	0	See 8.10
P23.16	Max. Speed	Sets the maximum speed when in forward (valid only when running in Vector control mode).	0.0~300.0 [%]	100.0 [%]	
P23.17	Max. Reverse Speed	Sets the maximum speed when in reverse (valid only when running in Vector control mode).	0.0~300.0 [%]	100.0 [%]	
P23.18	Min. Speed	Sets the minimum speed when in forward (valid only when running in Vector control mode).	0.0~300.0 [%]	0.0 [%]	
P23.19	Min. Reverse Speed	Sets the minimum speed when in reverse (valid only when running in Vector control mode).	0.0~300.0 [%]	0.0 [%]	
P23.20	Constant Power Speed Limit Enabled	[0]Disabled [1]Enabled	0~1	0	
P23.21	Constant Power Speed Limit Curve	[0]PARABOLIC [1]LINEAR	0~1	0	
P23.22	Speed Limit I @Min_Load	Valid only when running in constant power control mode.	0.0~300.0 [%]	160.0 [%]	
P23.23	Min_Load @Spd_Lmt_I	Valid only when running in constant power control mode.	0.0~200.0 [%]	20.0 [%]	
P23.24	Speed Limit II @Max_Load	Valid only when running in constant power control mode.	0.0~300.0 [%]	100.0 [%]	
P23.25	Max_Load @Spd_Lmt_II	Valid only when running in constant power control mode.	0.0~200.0 [%]	100.0 [%]	
P23.26	Position Loop Gain	Sets position loop gain.	0.0~1000.0	0.0	See

			[%]	[%]	8.10
P23.27	Position Loop Speed Compensation	Position loop output limit value, corresponding Max. Speed regulating variable.	0.00~15.00 [%]	2.00 [%]	See 8.10
P23.28	Speed Limit @Torque_Control	[0]Max. Speed Set: limited by the value of P23.16 and P23.17 [1]Ramp Function Input [2]Ramp Function Output [3]Profibus DP	0~3	0	
P23.30	Speed Offset Source (For torque control mode)	[0]Fixed Offset: the speed offset determined by the value of P23.31 and P23.32 [1]AI 1 [2]AI 2 [3]Local SET	0~3	0	
P23.31	FWD Speed_Offset	Sets forward speed offset.	0.0~100.0 [%]	5.0 [%]	
P23.32	REV Speed_Offset	Sets reverse speed offset.	0.0~100.0 [%]	5.0 [%]	
P23.34	Synchronal Compensation Enabled	[0]Disabled [1]Enabled	0~1	0	See 8.10
P23.35	Field Hold Time	Sets field hold time after stop.	0.0~100.0 [s]	0.0 [s]	
P23.36	Start Field Current	Sets start field current value.	50.0~150.0 [%]	110.0 [%]	
P23.37	Base Field	Sets the base field.	0.0~150.0 [%]	100.0 [%]	See 8.10
P23.38	Base Field END_Speed	Sets the end speed for base field.	0.0~100.0 [%]	25.0 [%]	See 8.10
P23.39	Top Field	Sets the top field.	0.0~120.0 [%]	100.0 [%]	See 8.10
P23.40	Top Field START_Speed	Sets the start speed for top field.	0.0~150.0 [%]	100.0 [%]	See 8.10
P23.41	Max. Field	Sets the maximum field.	0.0~150.0 [%]	135.0 [%]	
P23.42	Torque Detection	[0]Disabled [1]Enabled	0~1	1	
P23.43	Torque Detection Time	Sets torque detection time	25~1000 [ms]	75 [ms]	

		e.			
P23.44	Load Detection Time	Sets the time for weight detection. (Valid only when running in constant power control mode.)	25~1000 [ms]	250 [ms]	
P23.45	FWD_Torque @Zero Weight	Valid only when running in constant power control mode. (Weight)	0.0~100.0 [%]	22.0 [%]	
P23.46	REV_Torque @Zero Weight	Valid only when running in constant power control mode.	0.0~100.0 [%]	18.0 [%]	
P23.47	FWD_Torque @Weight under Test	Valid only when running in constant power control mode.	0.0~200.0 [%]	92.0 [%]	
P23.48	REV_Torque @Weight under Test	Valid only when running in constant power control mode.	0.0~200.0 [%]	87.0 [%]	
P23.49	Weight under Test	Valid only when running in constant power control mode.	0.0~150.0 [%]	100.0 [%]	
P23.51	Kp @OV_SUPPRESSION_Ctrl	Sets the proportional gain for overvoltage suppression.	0.0~1000.0 [%]	100.0 [%]	
P23.52	Ki @OV_SUPPRESSION_Ctrl	Sets the integral gain for overvoltage suppression.	0.0~1000.0 [%]	100.0 [%]	
P23.53	Kp @field_ctrl	Sets the proportional gain for field control.	0.0~1000.0 [%]	100.0 [%]	
P23.54	Ki @field_ctrl	Sets the integral gain for field control.	0.0~1000.0 [%]	100.0 [%]	
P23.55	K @Spd_Ctrl	Sets the proportional gain for speed control.	0.0~1000.0 [%]	100.0 [%]	See 8.10
P23.56	K_Weight @Brake_Ctrl	Sets the gain for brake control when in forward.	0.0~1000.0 [%]	100.0 [%]	See 8.10
P23.57	Field Discharge Enabled	[0]Disabled [1]Enabled	0~1	0	See 8.10
P23.58	Field Discharge Max. Current	Sets the Max. current value for field discharge	0.0~125.0 [%]	100.0 [%]	See 8.10
P23.59	Excitation after Field Discharge	Sets excitation value after field discharge stop	1.0~25.0 [%]	2.5 [%]	See 8.10
P23.60	DROOP Control Gain	DROOP is invalid when 0 is	0.0~100.0 [%]	0.0 [%]	See 8.10

		set			
P23.61	DROOP Control Filter Time	Adjust ROOP control response. Increase the value when vibrating and surging.	30~2000 [ms]	50 [ms]	See 8.10
P23.62	Kp @current_ctrl	Sets the proportional gain for current control.	0.0~1000.0 [%]	100.0 [%]	See 8.10
P23.63	Ki @current_ctrl	Sets the integral gain for current control.	0.0~1000.0 [%]	100.0 [%]	See 8.10
P23.64	Master_slave gain	Synchronization control gain	0.0~100.0 [%]	0	See 8.10
P23.65	MS Filter Time	Synchronization control filter time	30~2000ms	50	
P23.98	Jm @Acc_time	Sets the load inertia. (in units of time)	0.01~ 300.00 [s]	0.75 [s]	
P23.99	Bm @Friction Loss Factor	Sets the friction loss factor.	0.00~10.00 [%]	0.00 [%]	

7.24 MODBUS P32

Par. NO	Parameter Name	Description	Range	Default	Ref. Chapter
P32.0	MODBUS	[0] Disabled [1] Enabled	0~1	0	
P32.1	MODBUS Slave Station ID	According to the master station setting	1~255	1	
P32.2	Port Selection	[0]RS485 [1]RS232	0~1	0	
P32.3	Baud Rate Selection	[0] 9600 BPS; [1] 14400 BPS; [2] 19200 BPS; [3] 38400 BPS; [4] 56000 BPS; [5] 57600 BPS; [6] 115200 BPS;	0~6	3	
P32.4	Data Bits Checkout	[0] None_8_1_CFG; [1] Even_8_1_CFG; [2] Odd_8_1_CFG; [3] None_8_2_CFG;	0~5	0	

		[4] Even_8_2_CFG; [5] Odd_8_2_CFG;			
P32.5	Modbus Bus Fault Detection Time	Sets Modbus bus fault detection time. Detection is disabled when 0 is set, and Modbus bus fault will not be resulted.	0~100 [s]	0 [s]	When 0 is set, bus fault detection is disabled.
P32.6	Modbus Bus Status	Status Display: 0-bus normal; 1-bus fault	0~1	0	

7.25 PROFIBUS DP P33

Par. NO	Parameter Name	Description	Range	Default	Ref.
P33.0	COMMUNICATION	[0] Disabled [1] Enabled	0~1	0	
P33.1	STATION ADDRESS	According to the PLC.	1~255	1	
P33.2	MODE	[0] PPO 1 [1] PPO 2 [2] PPO 5 [3] GUIDE	0~3	2	
P33.3	MEMORY @INVERTER_IN	According to the communication mode.	0~16	14	
P33.4	MEMORY @INVERTER_OUT	According to the communication mode.	0~16	14	
P33.5	ERROR ACTION	[0] FAULT -> EMERGENCY STOP [1] NORMAL STOP -> FAULT [2] NORMAL STOP -> WARNING [3] IGNORE	0~3	0	
P33.6	Error Delay Time		0~1000 [ms]	50 [ms]	
P33.7	Error AUTO RESET	[0] Disabled [1] Enabled	0~1	0	
P33.8	Auto Reset Time		0.0~10.0 [s]	3.0 [s]	
P33.13	INVERTER_IN [W0]	See Table 7.2	0~37	0	
P33.14	INVERTER_IN [W0] @format	[0] ×1 [1] ×10 [2] ×100 [3] ×1000	0~4	0	

		[4] × 10000			
P33.15	INVERTER_IN [W1]	See Table7-2	0~37	0	
P33.16	INVERTER_IN [W1] @format	[0] × 1 [1] × 10 [2] × 100 [3] × 1000 [4] × 10000	0~4	0	
P33.17	INVERTER_IN [W2]	See Table7-2	0~37	0	
P33.18	INVERTER_IN [W2] @format	[0] × 1 [1] × 10 [2] × 100 [3] × 1000 [4] × 10000	0~4	0	
P33.19	INVERTER_IN [W3]	See Table7-2	0~37	0	
P33.20	INVERTER_IN [W3] @format	[0] × 1 [1] × 10 [2] × 100 [3] × 1000 [4] × 10000	0~4	0	
P33.21	INVERTER_IN [W4]	See Table7-2	0~37	1	
P33.22	INVERTER_IN [W4] @format	[0] × 1 [1] × 10 [2] × 100 [3] × 1000 [4] × 10000	0~4	0	
P33.23	INVERTER_IN [W5]	See Table7-2	0~37	18	
P33.24	INVERTER_IN [W5] @format	[0] × 1 [1] × 10 [2] × 100 [3] × 1000 [4] × 10000	0~4	2	
P33.25	INVERTER_IN [W6]	See Table7-2	0~37	21	
P33.26	INVERTER_IN [W6] @format	[0] × 1 [1] × 10 [2] × 100 [3] × 1000 [4] × 10000	0~4	1	
P33.27	INVERTER_IN [W7]	See Table7-2	0~37	22	
P33.28	INVERTER_IN [W7] @format	[0] × 1 [1] × 10 [2] × 100	0~4	1	

		[3] × 1000 [4] × 10000			
P33. 29	INVERTER _IN [W8]	See Table7-2	0~37	23	
P33. 30	INVERTER _IN [W8] @format	[0] × 1 [1] × 10 [2] × 100 [3] × 1000 [4] × 10000	0~4	1	
P33. 31	INVERTER _IN [W9]	See Table7-2	0~37	0	
P33. 32	INVERTER _IN [W9] @format	[0] × 1 [1] × 10 [2] × 100 [3] × 1000 [4] × 10000	0~4	0	
P33. 33	INVERTER _IN [W10]	See Table7-2	0~37	0	
P33. 34	INVERTER _IN [W10] @format	[0] × 1 [1] × 10 [2] × 100 [3] × 1000 [4] × 10000	0~4	0	
P33. 35	INVERTER _IN [W11]	See Table7-2	0~37	0	
P33. 36	INVERTER _IN [W11] @format	[0] × 1 [1] × 10 [2] × 100 [3] × 1000 [4] × 10000	0~4	0	
P33. 37	INVERTER _IN [W12]	See Table7-2	0~37	0	
P33. 38	INVERTER _IN [W12] @format	[0] × 1 [1] × 10 [2] × 100 [3] × 1000 [4] × 10000	0~4	0	
P33. 39	INVERTER _IN [W13]	See Table7-2	0~37	0	
P33. 40	INVERTER _IN [W13] @format	[0] × 1 [1] × 10 [2] × 100 [3] × 1000 [4] × 10000	0~4	0	
P33. 41	INVERTER _IN [W14]	See Table7-2	0~37	0	
P33. 42	INVERTER _IN [W14] @format	[0] × 1 [1] × 10	0~4	0	

		[2] × 100 [3] × 1000 [4] × 10000			
P33. 43	INVERTER_IN [W15]	See Table7-2	0~37	0	
P33. 44	INVERTER_IN [W15] @format	[0] × 1 [1] × 10 [2] × 100 [3] × 1000 [4] × 10000	0~4	0	
P33. 45	INVERTER_OUT [W0]	See Table7-3	0~48	0	
P33. 46	INVERTER_OUT [W0] @format	[0] × 1 [1] × 10 [2] × 100 [3] × 1000 [4] × 10000 [5] [%] × 1 [6] [%] × 10 [7] [%] × 100	0~7	0	
P33. 47	INVERTER_OUT [W1]	See Table7-3	0~48	0	
P33. 48	INVERTER_OUT [W1] @format	[0] × 1 [1] × 10 [2] × 100 [3] × 1000 [4] × 10000 [5] [%] × 1 [6] [%] × 10 [7] [%] × 100	0~7	0	
P33. 49	INVERTER_OUT [W2]	See Table7-3	0~48	0	
P33. 50	INVERTER_OUT [W2] @format	[0] × 1 [1] × 10 [2] × 100 [3] × 1000 [4] × 10000 [5] [%] × 1 [6] [%] × 10 [7] [%] × 100	0~7	0	
P33. 51	INVERTER_OUT [W3]	See Table7-3	0~48	0	
P33. 52	INVERTER_OUT [W3] @format	[0] × 1 [1] × 10 [2] × 100 [3] × 1000 [4] × 10000	0~7	0	

		[5] [%] × 1 [6] [%] × 10 [7] [%] × 100			
P33. 53	INVERTER_OUT [W4]	See Table7-3	0~48	1	
P33. 54	INVERTER_OUT [W4] @format	[0] × 1 [1] × 10 [2] × 100 [3] × 1000 [4] × 10000 [5] [%] × 1 [6] [%] × 10 [7] [%] × 100	0~7	0	
P33. 55	INVERTER_OUT [W5]	See Table7-3	0~48	19	
P33. 56	INVERTER_OUT [W5] @format	[0] × 1 [1] × 10 [2] × 100 [3] × 1000 [4] × 10000 [5] [%] × 1 [6] [%] × 10 [7] [%] × 100	0~7	2	
P33. 57	INVERTER_OUT [W6]	See Table7-3	0~48	26	
P33. 58	INVERTER_OUT [W6] @format	[0] × 1 [1] × 10 [2] × 100 [3] × 1000 [4] × 10000 [5] [%] × 1 [6] [%] × 10 [7] [%] × 100	0~7	6	
P33. 59	INVERTER_OUT [W7]	See Table7-3	0~48	30	
P33. 60	INVERTER_OUT [W7] @format	[0] × 1 [1] × 10 [2] × 100 [3] × 1000 [4] × 10000 [5] [%] × 1 [6] [%] × 10 [7] [%] × 100	0~7	1	
P33. 61	INVERTER_OUT [W8]	See Table7-3	0~48	14	
P33. 62	INVERTER_OUT [W8] @format	[0] × 1 [1] × 10	0~7	0	

		[2] × 100 [3] × 1000 [4] × 10000 [5] [%] × 1 [6] [%] × 10 [7] [%] × 100			
P33. 63	INVERTER _OUT [W9]	See Table7-3	0~48	13	
P33. 64	INVERTER _OUT [W9] @format	[0] × 1 [1] × 10 [2] × 100 [3] × 1000 [4] × 10000 [5] [%] × 1 [6] [%] × 10 [7] [%] × 100	0~7	0	
P33. 65	INVERTER _OUT [W10]	See Table7-3	0~48	40	
P33. 66	INVERTER _OUT [W10] @format	[0] × 1 [1] × 10 [2] × 100 [3] × 1000 [4] × 10000 [5] [%] × 1 [6] [%] × 10 [7] [%] × 100	0~7	6	
P33. 67	INVERTER _OUT [W11]	See Table7-3	0~48	0	
P33. 68	INVERTER _OUT [W11] @format	[0] × 1 [1] × 10 [2] × 100 [3] × 1000 [4] × 10000 [5] [%] × 1 [6] [%] × 10 [7] [%] × 100	0~7	0	
P33. 69	INVERTER _OUT [W12]	See Table7-3	0~48	0	
P33. 70	INVERTER _OUT [W12] @format	[0] × 1 [1] × 10 [2] × 100 [3] × 1000 [4] × 10000 [5] [%] × 1	0~7	0	

		[6] [%] × 10 [7] [%] × 100			
P33. 71	INVERTER _OUT [W13]	See Table7-3	0~48	0	
P33. 72	INVERTER _OUT [W13] @format	[0] × 1 [1] × 10 [2] × 100 [3] × 1000 [4] × 10000 [5] [%] × 1 [6] [%] × 10 [7] [%] × 100	0~7	0	
P33. 73	INVERTER _OUT [W14]	See Table7-3	0~48	0	
P33. 74	INVERTER _OUT [W14] @format	[0] × 1 [1] × 10 [2] × 100 [3] × 1000 [4] × 10000 [5] [%] × 1 [6] [%] × 10 [7] [%] × 100	0~7	0	
P33. 75	INVERTER _OUT [W15]	See Table7-3	0~48	0	
P33. 76	INVERTER _OUT [W15] @format	[0] × 1 [1] × 10 [2] × 100 [3] × 1000 [4] × 10000 [5] [%] × 1 [6] [%] × 10 [7] [%] × 100	0~7	0	

Table 7.2: Description of INVERTER_IN Words

Value	Description
0	NULL
1	CTWO
2	CTW1

3	CTW2
4	CTW3
5	CTW4
6	Encoder High Order [32]
7	Encoder Low Order [32]
8	32_MSW
9	32_LSW
10	Digital Output
11	PA_CTRL
12	PA 0 @32bit
13	PA 1 @32bit
14	PA 2 @32bit
15	PA 3 @32bit
16	PA 4 @32bit
17	PA 5 @32bit
18	Frequency Set [Hz]
19	Speed Set [rpm]
20	Speed Set [%]
21	Torque Set [%]
22	Torque Limit Set [%]
23	Speed Limit Set [Hz]
24	Active Currset Set [%]
25	Reactive Current Set [%]
26	A01 Set [%]
27	A02 Set [%]
28	Accel_Time_CTRL
29	Decel_Time_CTRL
30~37	SET_W12~19

Table 7.3: Description of INVERTER_OUT Words

Value	Description
0	NULL
1	STW0
2	STW1

3	STW2
4	STW3
5	STW4
6	STW5
8	PA 1 @32bit
9	PA 2 @32bit
10	PA 3 @32bit
11	PA 4 @32bit
12	PA 5 @32bit
13	Encoder High Order [32]
14	Encoder Low Order[32]
15	32bit_MSW
16	32bit_LSW
17	Digital Input
18	Digital Output
19	Output Frequency
20	Motor Speed [rpm] @Estimate
21	Motor Speed [rpm]
22	DC-Link Voltage
23	DC-Link Voltage @filter
24	Temp
25	Torque
26	Load Torque
27	RMS Current @A-phase
28	RMS Current @B-phase
29	RMS Current @C-phase
30	RMS Current
31	Output Voltage
32	Frequency Set
33	AI 1
34	AI 2
35	Output Power

36	Torque @filter
37	Load @filter
38	Load Weight
39	Current_Peak_Detect
40	Torque Set
41	Mwh Motor
42	Kwh Motor
43	Mwh Generation
44	Kwh Generation
45~48	AW26~29

8. Specified parameter function description

8.1 Parallel running and panel observation setting

Parallel running setting

Inverter greater than 400KW can be obtained by a combination of two inverters, for example, 800KW requires a combination of two 400KW inverters, then there is need to set the corresponding parameter P2.0(parallel running setting).

8.2 Digital input

(1)Multi-speed control

Multi-speed command value to be set based on P12.0 (multi-speed setting mode)

[0] Direct Step Input or [1] Bit Decoding.

A. [0] Direct Step Input

[1] RUN (Running forward) [2] RUN @REVERSE (Running reverse) --- segment 1

[6] M_STEP1 (Bit 0) (Multi-speed terminal segment 1) --- 2

[7] M_STEP2 (Bit 1) (multi- speed terminal segment 2) --- 3

[8] M_STEP3 (Bit 2) (multi- speed terminal segment 3) --- 4

[9] M_STEP4 (Bit 3) (multi- speed terminal segment 4) --- 5

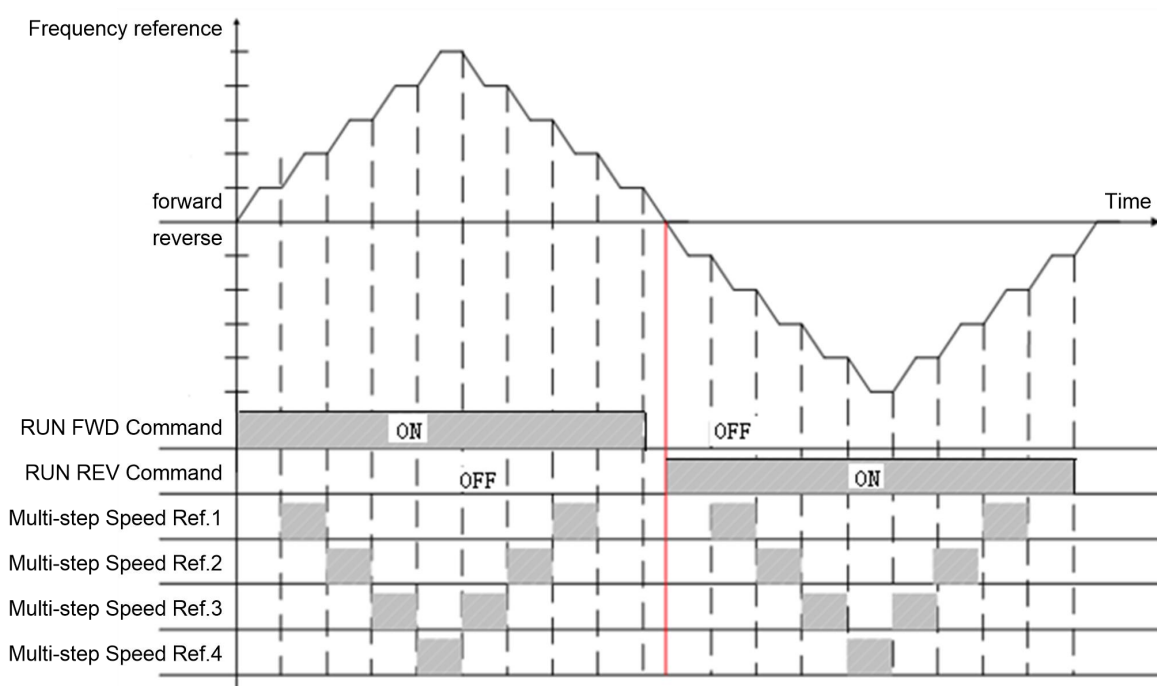

B. [1] Bit Decoding

The graphic below represents a speed of 16 stages (calculate with the 8421 decoding) that constituted of 4 multi-speed segments. When only input forward (FORWARD) or reverse (REVERSE) signals, it runs with the value that is greater in parameter P12.2 (multispeed 1 setting value) and the min. speed.

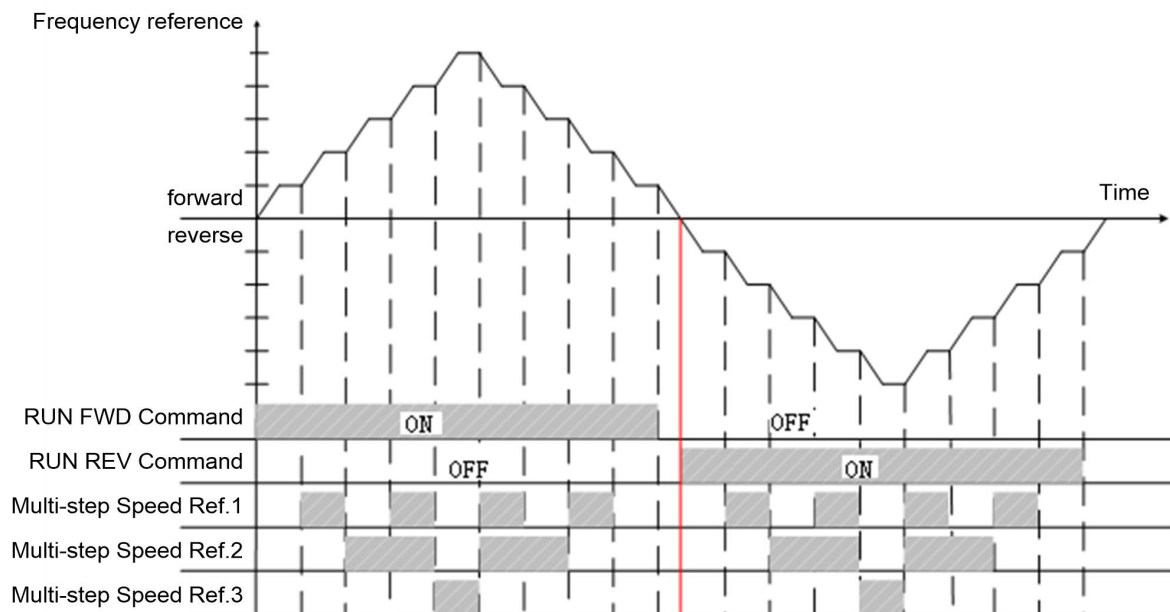

(2) Brake switch status

When setting the DI to [22] BRAKE-SW STATUS, if the absolute value of motor speed is more than 10Hz, but the signal of DI is low, The errorcode will be E106. If the absolute value of motor speed is less than 10Hz, but the signal of DI is low in 2 second. The errorcode will be E107.

8.3 Digital output

Brake release control

It is the inverter that controls the brake on / off signals when the motor is attached with braking function. Horizontal load brake signal is set as [1] running signal or [3] motor brake. Vertical load brake signal is set as [3] motor brake.

Please refer to the diagram for the output signal differences between [1] running signal and [3] motor brake:

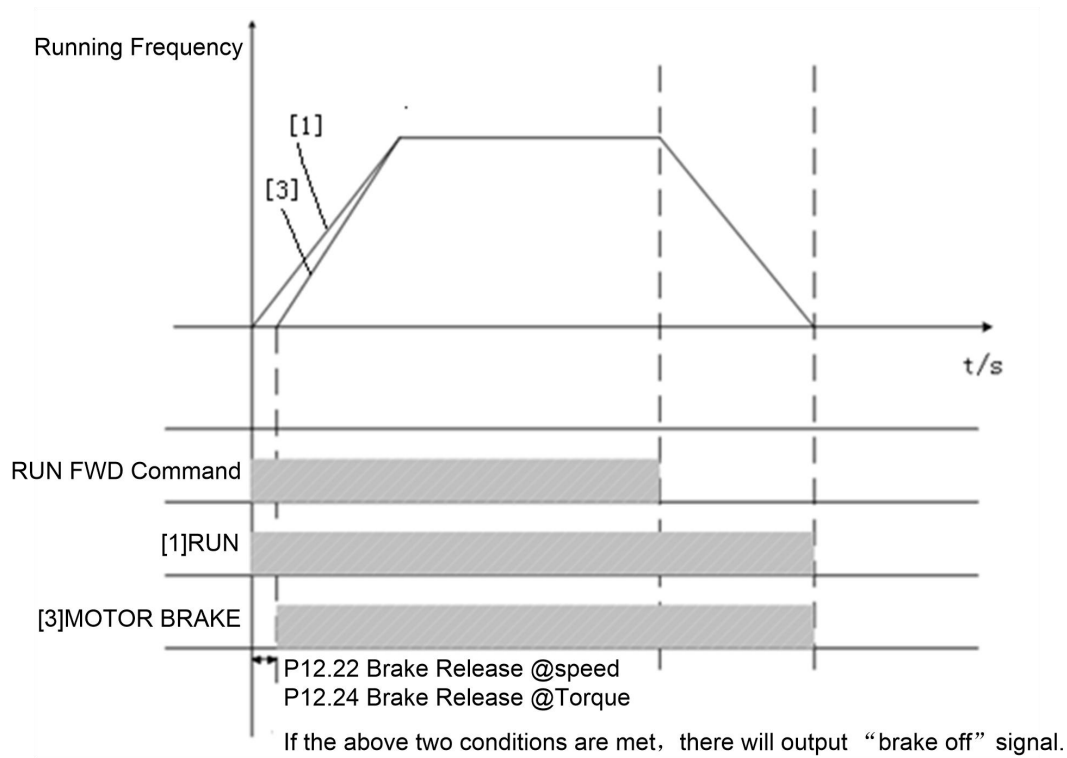

8.4 Analog input

Analog input settings are shown below:

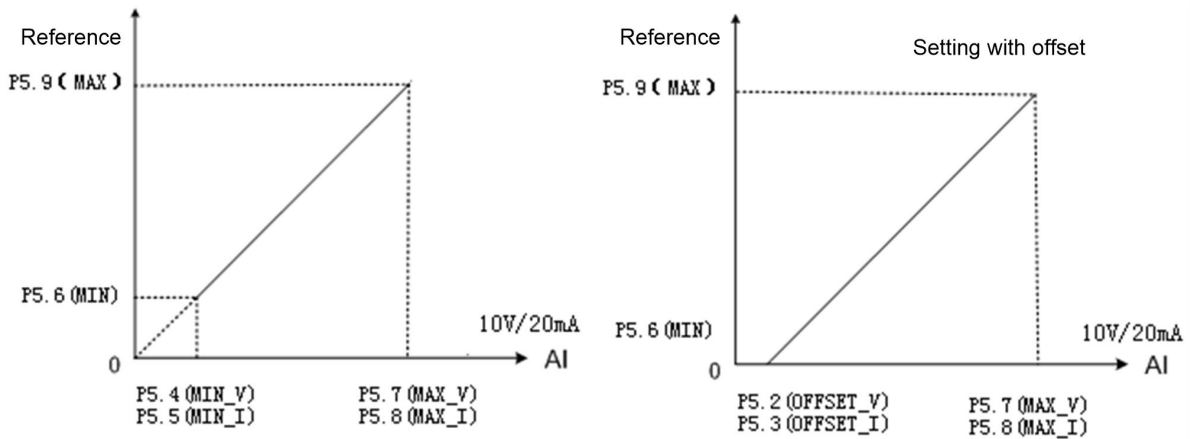

8.5 Analog output

Analog output settings are shown below:

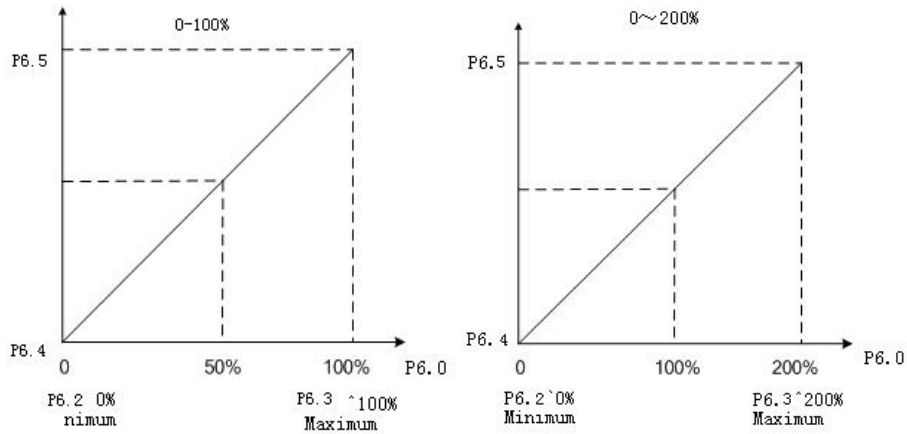

(a) Output setting range is 0-100%

(b) Output setting range is 0-200%

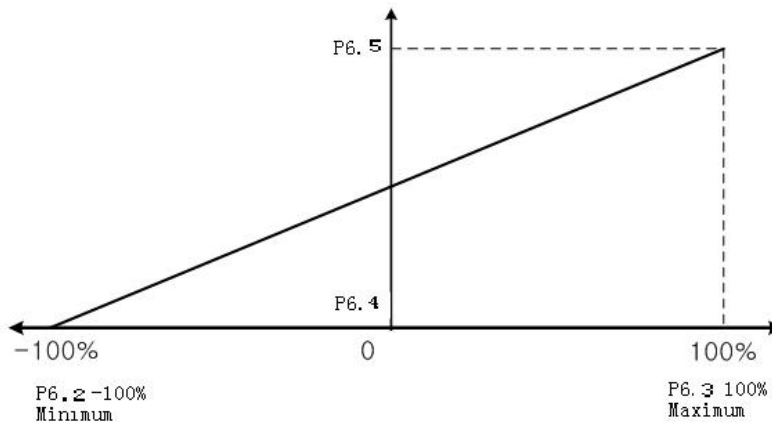

(c) Output setting range is -100-100%

8.6 Protection parameter

(1) Current limit function

P7.0, P7.1, P7.2, P7.3 current limit function: It is used to limit large current flowing through the motor. This function is activated when the motor current exceeds the limit value.

(2) Overcurrent protection function

P7.4, P7.5, P7.6, P7.7 overcurrent protection function: When the motor current exceeds the value that is the result of parameter P7.4 multiplied by the parameter P16.4, this function is activated to cut off the inverter output. This value is the percentage of motor rated current value.

(3) Zero sequence current protection

P7.8, P7.9, P7.10, P7.11 zero sequence current protection value: sum of inverter output

three-phase current: $I_a + I_b + I_c$; motor rated current: P16.4, when meet the condition of

$\frac{(I_a + I_b + I_c)}{3} > P7.8 \times P16.4 \times 1.414$, this function is activated and the inverter output will be shut off.

Note: the motor will report zero sequence current faults when there is a short circuit or grounding of three phases of motor.

(4) Bus over-voltage/under-voltage protection:

P7.12, P7.13 bus over-voltage or low voltage protection function: when bus voltage of the inverter exceeds the value of parameter P7.12, this function is activated and the output will be shut off. When bus voltage of the inverter is less than the value of parameter P7.12, this function is activated and the inverter output will be shut off. It is suggested to set as default setting value.

(5) Temperature protection

P7.14 temperature protection function: the inverter IGBT temperature exceeds the value of parameter P7.14, this function is activated and the inverter output will be shut off, inverter overtemperature faults will be reported.

P7.15 over-temperature alarm function: the inverter IGBT temperature exceeds the value of parameter P7.15, this function is activated but the inverter output will not be shut off.

(6) Over-speed protection

P7.19, P7.20, P7.21, P7.22 overspeed protection function: When the motor speed exceeds the value of parameter P7.19, this function is activated and the inverter output will be shut off. Value of P7.19 ~ P7.22 is the percentage of the motor rated speed value.

(7) Open-loop vector starting protection

P7.23 protection is available only in open-loop vector control mode (P16.11 = 1). When P7.23 is set to maximum, this protection function is prohibited. In open-loop vector control mode, if the starting torque is low or magnetic field is not established, the ability to follow a given motor speed is poor at the starting moment, and if the lasting time exceeds the set value of P7.23, this function is activated and the inverter output is shut off.

P7.24 ~ P7.26 protection is available only in the open-loop vector control mode (P17.11=1、P18.11=1、P19.11=1) and just for some specific motors.

(8) Over-load protection function

P7.31, P7.32 overload protection: when the motor current exceeds the current protection value, this function is activated and the inverter output is shut off. Its protection parameters are shown as below:

P7.31, P7.32 abnormal speed protection function is available only in closed loop vector control mode (P16.11 = 2). P7.31 sets the deviation value of speed abnormality, 100% corresponding to the rated motor frequency. P7.32 sets the detection time of speed abnormality. When the difference between the encoder detection speed and the reference speed exceeds the value set by P7.31, and run the time set by P7.32, this function is activated and the inverter output is shut off.

(9) Autotuning protection

P7.33 sets the autotuning failed time working in static autotuning operation. When the static autotuning time exceeds P7.33, this function is enabled, and the static autotuning is terminated.

(10) Overload protection function

P7.48, P7.50 overload protection: this function is activated when the motor current exceeds the current protection value, and the inverter output is shut off. Its protection parameters are shown as follows:

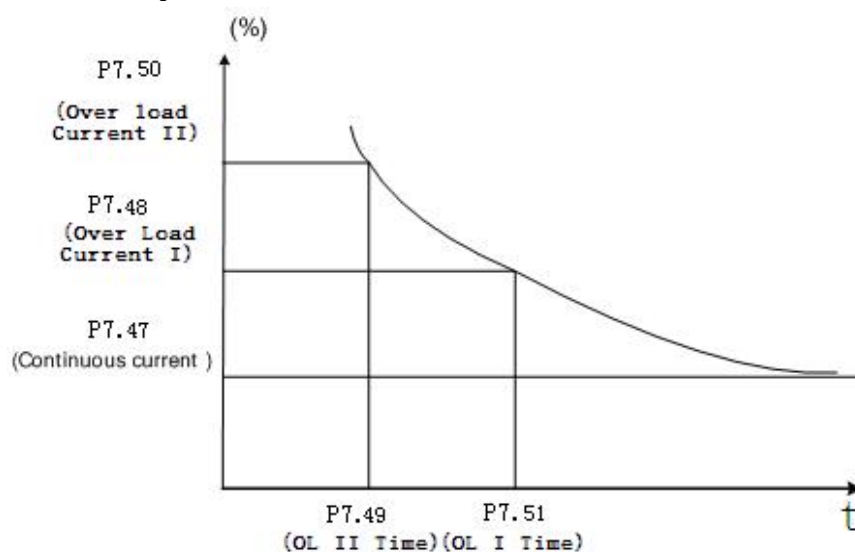

(11) Built-in brake unit

Parameter values of P7.64, P7.65, and P7.66 are valid only when the inverter has a built-in brake unit, which means inverter HF630 series of 110KW and below are valid with this function. Set P7.64 value as 1 to enable this function. If bus voltage is higher than the set value of P7.65, the brake unit is turned on. Brake full turn-on voltage value is determined by the value of P7.66, and brake full turn-on voltage value must be not less than the set value of brake start voltage, thus require $P7.66 \geq P7.65$. When P16.0 input voltage is set to 380V and P7.65 is 0V, the brake start voltage is 597V; when P7.66 is 20V, the brake unit off voltage is 617V. Calculated as follows:

Brake start voltage value = $1.075 \times \sqrt{2} \times P16.0 + 20 + P7.65$;

Brake full turn-on voltage value = $1.075 \times \sqrt{2} \times P16.0 + 20 + P7.66$ 。

(12) Overvoltage suppression function

The parameters of P7.69, P7.70, P7.71 can affect the actual motor deceleration time after functioning; when the P7.69 default value is 0, the inverter must be connected with the brake unit and resistance. When p16.0 input voltage is set to 380v, overvoltage suppression value is 611v. Calculation formula: overvoltage suppression value = $1.1 \times \sqrt{2} \times P16.0 + 20 + P7.70$. Specify as below:

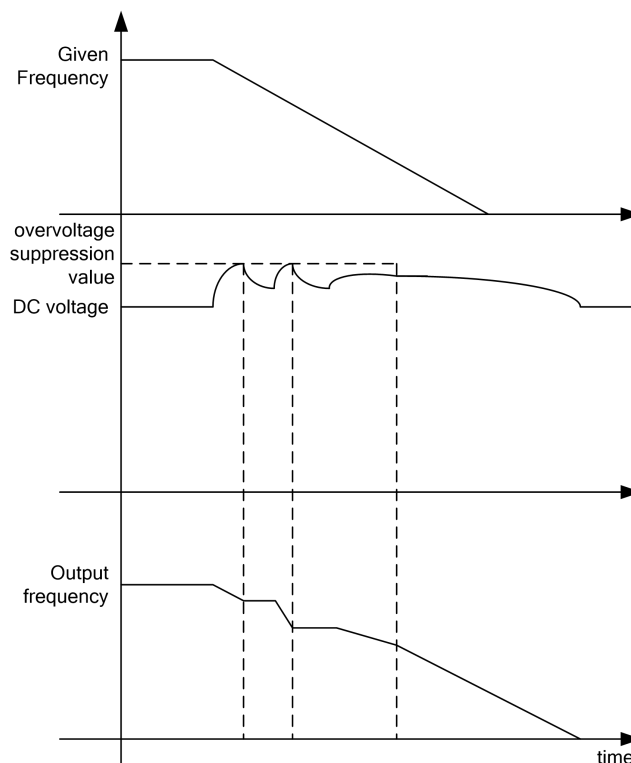

when the P7.71 is "Enable", the software will changing the motor deceleration time and increasing motor field to realize overvoltage suppression function; when the P7.71 is "Disable" the software will only changing the motor deceleration time to realize overvoltage suppression function.

8.7 Motor start/stop control parameters

(1) Stop mode

P8.3 Stop mode: methods of setting motor speed deceleration when it stops. See the graphic below.

[0] Ramp parking: motor speed will be slowly decelerated until zero according to the set deceleration time.

[1] Free parking: While implementing stop mode, the inverter output voltage is immediately cut off at the same time.

P8.6 Start delay time: from the moment the inverter commands "start", the inverter will remain "stop status" for a period of time within the set time value of P8.6, then the startup mode will be activated. See the graphic below:

P8.7 Stop state hold time: even if the motor speed turns to zero, in a period of time within this set parameter value, the inverter will still remain running mode, where there is still a torque output, only after such time of period then a real sense of parking will be achieved. See the graphic below:

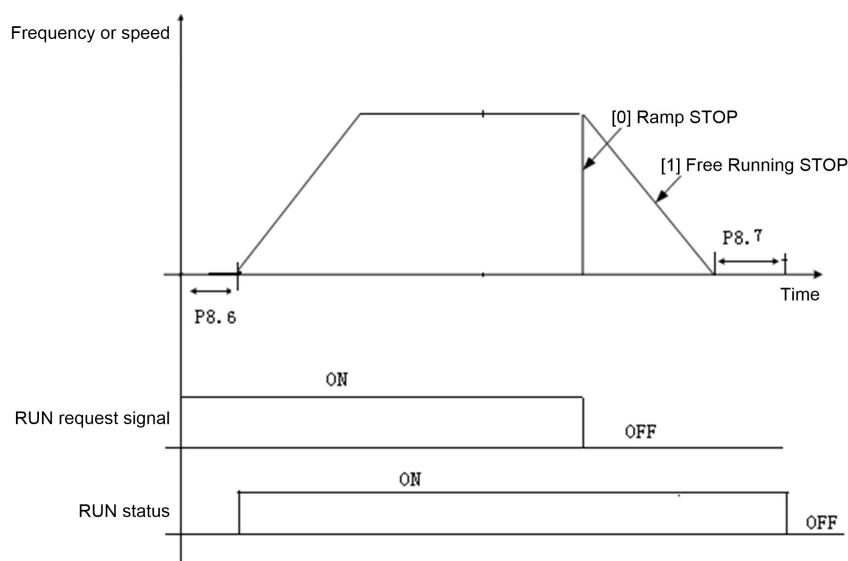

Stop mode control graphic

(2) Acceleration/Deceleration control:

During the inverter is running, time and mode of acceleration/deceleration is adjustable. P8.14 is the multiplier of acceleration time adjustment, it means the actual acceleration time is the result of set acceleration time multiplying by the value of the of P8.14. P8.33 is the multiplier of deceleration time adjustment, it means the actual deceleration time is the result of set deceleration time multiplying by the value of the of P8.33.

Acceleration mode with multi-speed situations are shown as below:

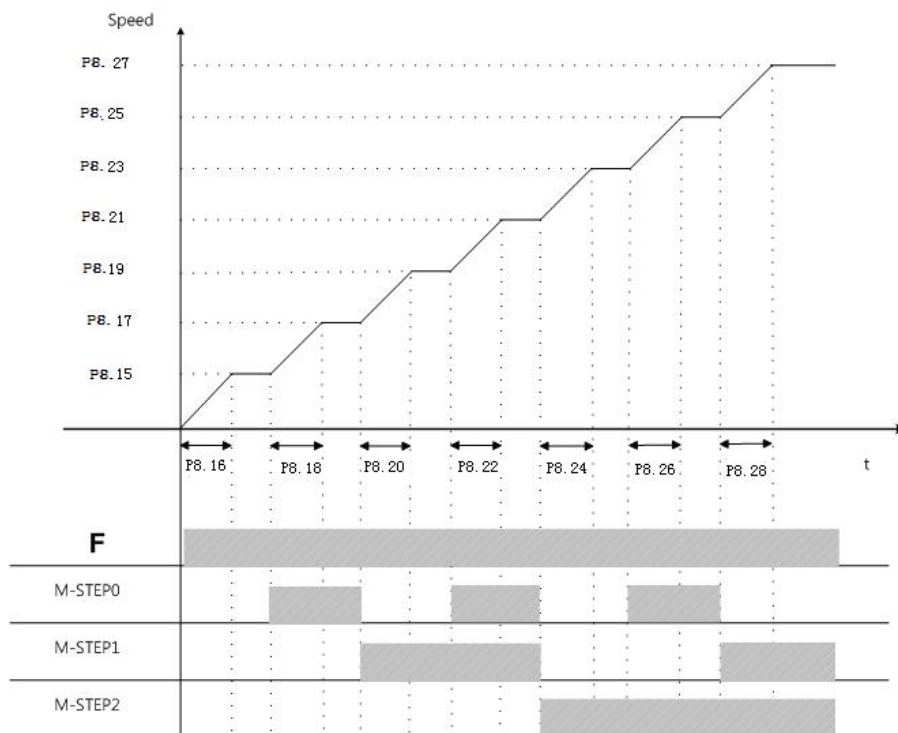

When setting the value of the acceleration region, the following requirement must be obeyed:

$$8.15 < P8.17 < P8.19 < P8.21 < P8.23 < P8.25 < P8.27$$

Take the parameter settings for motor running with rated speed as an example:

P8.15	P8.17	P8.19	P8.21	P8.23	P8.25	P8.27
10%	20%	30%	50%	60%	80%	100%

Deceleration mode with multi-speed situations are shown as below:

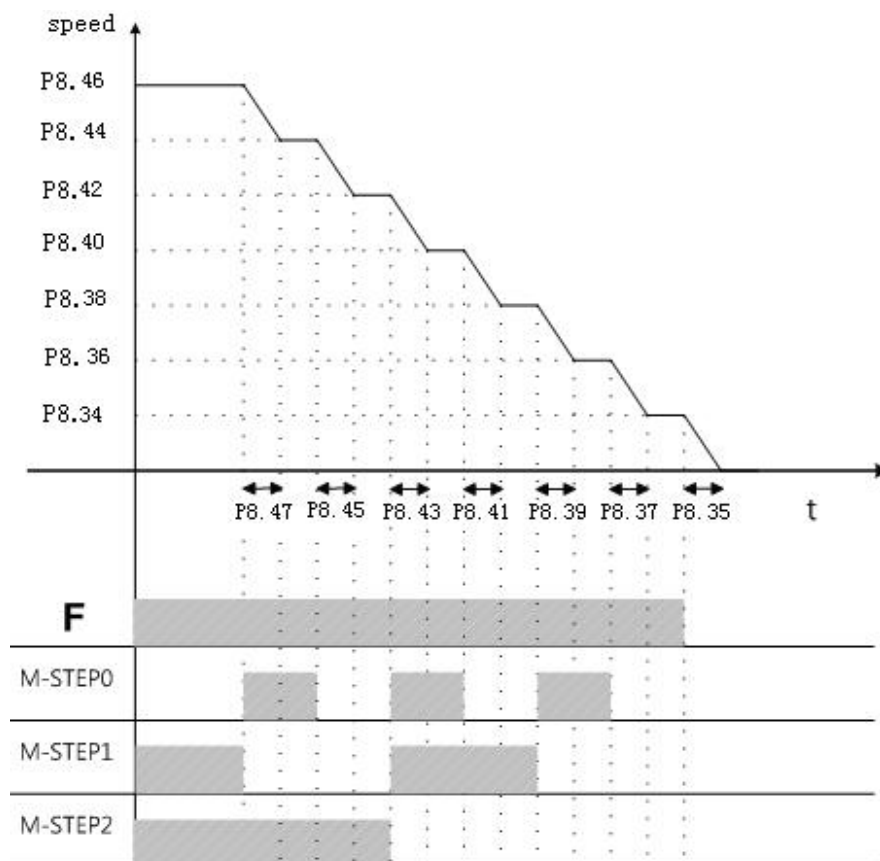

When setting the value of the deceleration region, requirement as the parameter value $P8.34 < P8.36 < P8.38 < P8.40 < P8.42 < P8.44 < P8.46$ must be obeyed, otherwise it occurs to inverter as parameter setting error.

Take the parameter settings for motor running with rated speed as an example:

P8.34	P8.36	P8.38	P8.40	P8.42	P8.44	P8.46
10%	20%	30%	50%	60%	80%	100%

(3) Acceleration and deceleration adjustment:

During operation, the acceleration and deceleration time multiple can be modified with PROFIBUS or MODBUS communication. Set the acceleration time control sources by P8.13 and the deceleration time control sources by P8.32. It also can be disabled, so that this function does not work. Example:

Acceleration zone 1 acceleration time = $P8.14 \times P8.16 \times (\text{communication given time acceleration multiples} \times 0.001)$;

Deceleration zone 1 deceleration time = $P8.33 \times P8.35 \times (\text{communication given time deceleration multiples} \times 0.001)$.

8.8 Motor multi-speed and brake control

(1) The relations between terminals and multi-speed

P12.2 ~ P12.17 multispeed is the speed reference values for setting inverter multi-speed operation. The following figure shows the relations between the multi-speed terminals and multi-speed segments by taking P12.0 = 1 as an example:

Running segment	Multi-speed terminal 1	Multi-speed terminal 2	Multi-speed terminal 3	Multi-speed terminal 4
Multi-speed 1	0	0	0	0
Multi-speed 2	1	0	0	0
Multi-speed 3	0	1	0	0
Multi-speed 4	1	1	0	0
Multi-speed 5	0	0	1	0
Multi-speed 6	1	0	1	0
Multi-speed 7	0	1	1	0
Multi-speed 8	1	1	1	0
Multi-speed 9	0	0	0	1
Multi-speed 10	1	0	0	1
Multi-speed 11	0	1	0	1
Multi-speed 12	1	1	0	1
Multi-speed 13	0	0	1	1
Multi-speed 14	1	0	1	1
Multi-speed 15	0	1	1	1
Multi-speed 16	1	1	1	1

0 represents the multi-speed terminal OFF 1 represents multi-speed terminal ON

(2) Brake on/off control

P12.22 ~ P12.35 when using electromagnetic brake system, use this function to control the brake on/off. Only when digital output terminal is set as [3] MOTOR BRAKE, the brake control function will be effective.

When the motor is stopped, If the inverter receives running signal, it will give motor its corresponding torque values according to their forward and reverse directions. If the following conditions are met, there will be “brake off” signals on the brake control output relay or output terminals.

When the motor is running, if the inverter receives stop signal, the motor will start to decelerate. If the output frequency reaches parameter [brake on speed (Brake Closure @ speed)] values , there will be “brake on” signals on its corresponding output terminals.

Note: The torque and speed setting values to be set the on the basis of motor parameters in group P16.

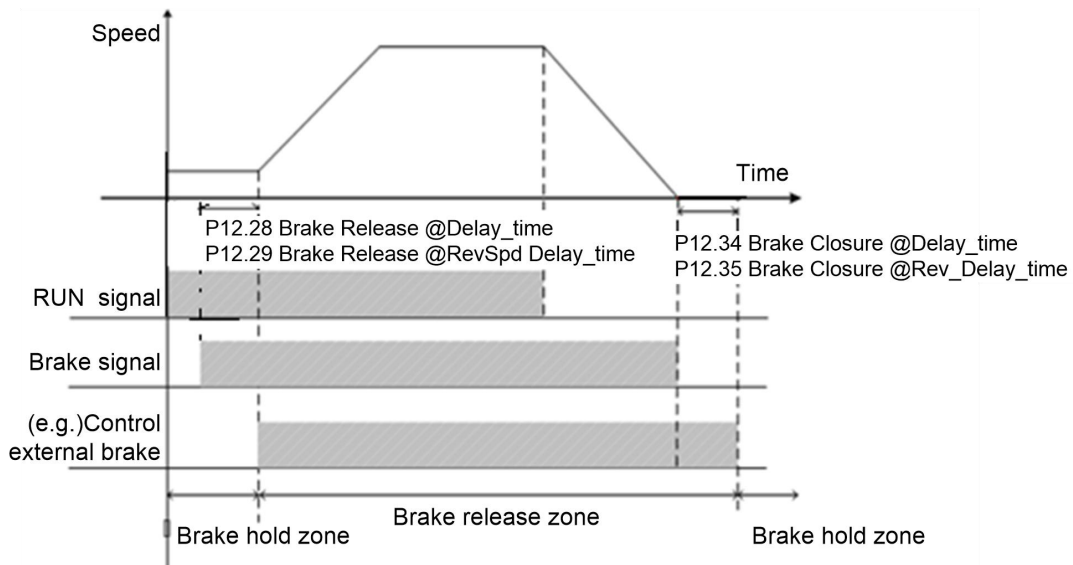
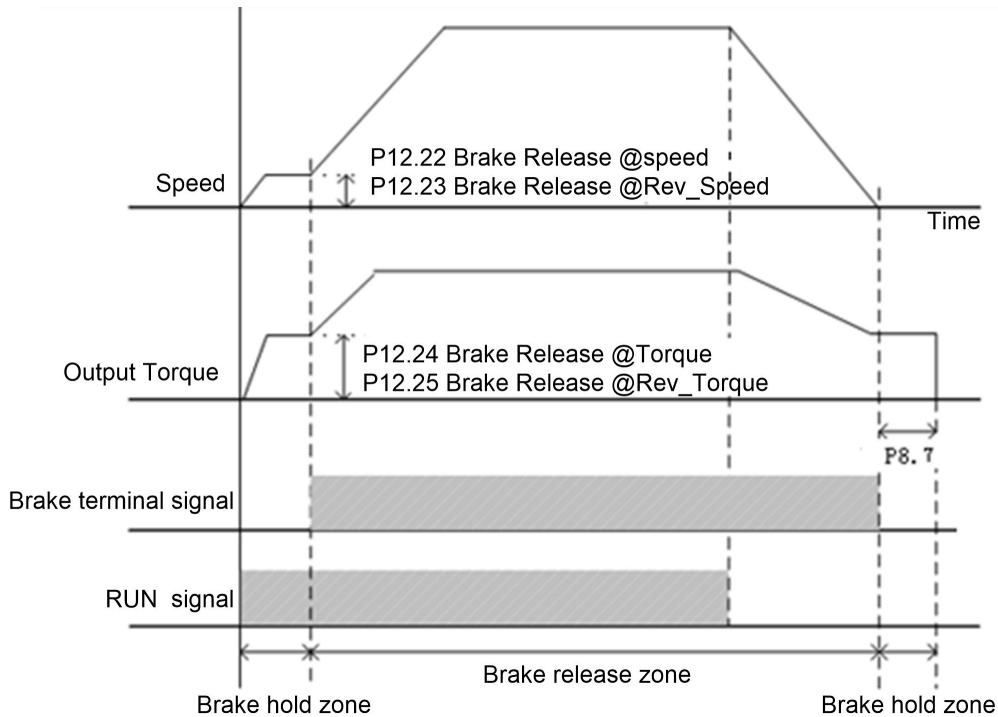

8.9 Motor basic parameters and V/F control parameters

(1) Motor rated parameters

P16.0 ~ P16.9 motor parameters: In order to invert the motor correctly, the motor parameters on the nameplate must be confirmed and the corresponding parameters of the inverter should be entered, if the motor parameters are

incorrectly entered, it may cause inverter abnormal and failure in auto-tuning. P16.7 the number of motor poles is set according to the following formula: Value $120 \times P16.5/P16.6$ and get rounded. P16.9 synchronous speed is set according to the following formula: $120 \times P16.5/P16.7$.

When two motors are connected in parallel, values of P16.2 (rated power) and P16.4 (rated current) are the accumulated value of these two parameters on both motor nameplates.

(2) Carrier frequency

P16.12 carrier frequency is mainly used to improve the motor running noise and inverter disturbance to surroundings.

The advantages of a high carrier frequency: the current waveform is relatively ideal, less current harmonics, and low motor noise;

The disadvantages of a high carrier frequency: the switching losses increase, the inverter temperature increases, the output capacity of the inverter is affected, while the inverter leakage current increases, and the inverter disturbance to surroundings increases. With high carrier frequency, it is necessary to derate the inverter.

Low carrier frequency is contrary to the above-mention, but if the carrier frequency is too low, it may cause instability in the low-frequency operation, reduced torque or even oscillation.

The figure below shows the impact on the environment from carrier frequency:

Carrier frequency	Electromagnetic noise	Leaking current	Heat value
1KHz	The higher the carrier frequency, the smaller the electromagnetic noise is.	The higher the carrier frequency is, the greater the leaking current is.	The higher the carrier frequency is, the higher the heat value is.
5KHz			
10KHz			

The following table shows the relationship between the model and the carrier frequency:

Model	Carrier frequency (Factory value: KHz)
0.4KW~30KW	5
37KW~110KW	3

(3) V/F curve selection

P16.14 Parameters are effective only in the V/F control (P16.11 = 0), for vector control is invalid.

[0] Linear Curve V/F. It is applied to ordinary constant torque load.

[1] Multi-point Curve V/F. V/F curve can be defined by setting parameters of (P16.33 ~ P16.45).

[2] Square Curve V/F. It is suitable for variable torque load applications, such as: fans, pumps, etc.

All curves are shown as below:

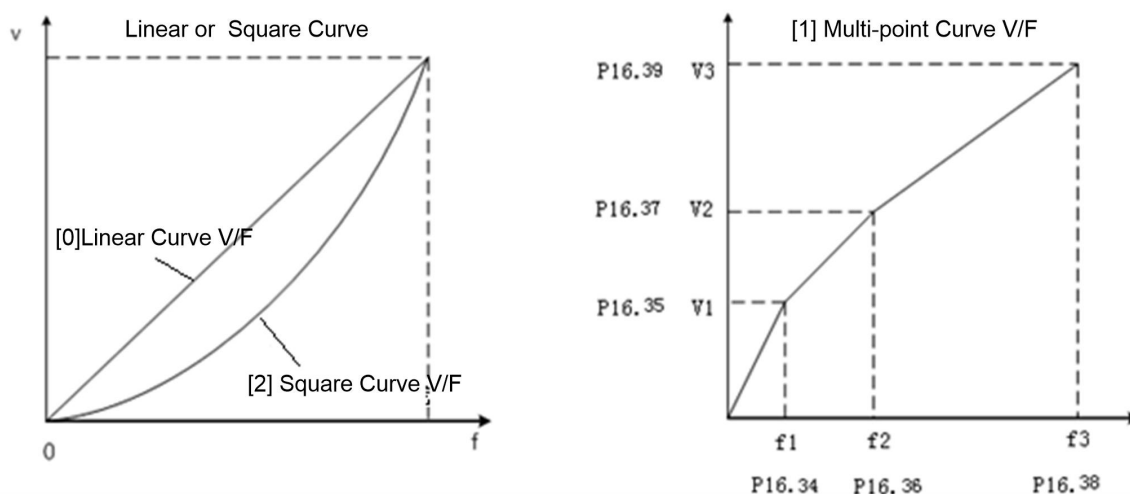

P16.34 ~ P16.45 twelve parameters define multi-point V/F curve. V/F curve is usually set based on the load characteristics of the motors. Note: $V1 < V2 < V3$, $f1 < f2 < f3$. If the set value of low-frequency voltage is too high, it may cause the motor overheat and even burn down, and the inverter stalling or overcurrent protection.

(4) Torque compensation

P16.15 torque compensation is valid only in the V/F control mode. This parameter is enabled when the starting torque is a little bit low. But this parameter can be enabled only after the static auto-tuning has been completed in V/F control mode. Enabling this parameter will increase starting current and starting voltage, over-current phenomenon may occur. It is suggested to enable this parameter only when a large amount of starting torque (mixer, brick kiln, etc.) is required.

(5) Start excitation current

When P16.14= [0] line V/F curve, V/F start compensating voltage setting value

is p16.30. P16.26 and P16.27 can be set with reference to the following figure:

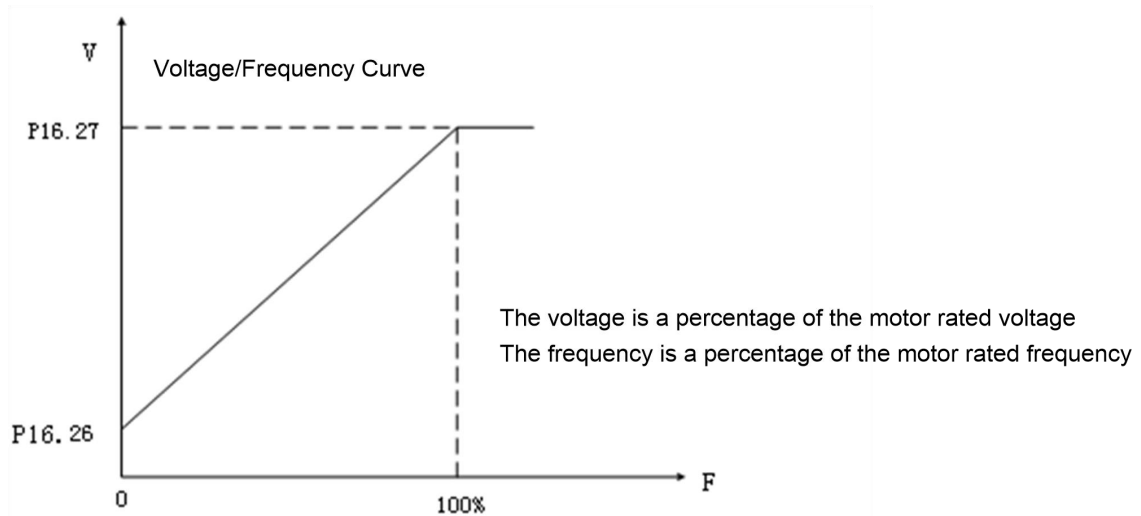

When P16.14= [2] square curve, V/F start compensating voltage setting value is p16.30. P16.30 and P16.27 can be set with reference to the following figure:

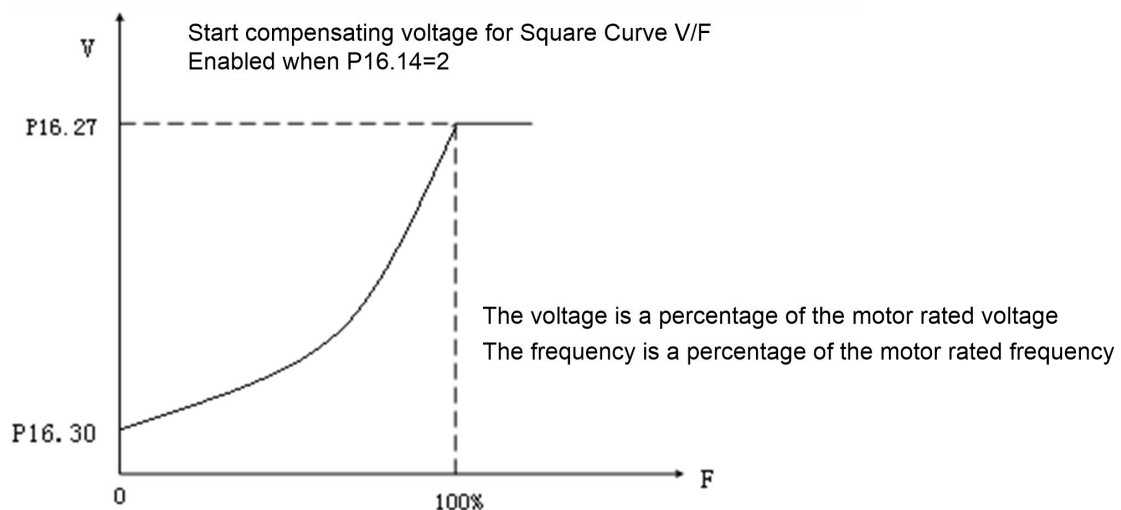

(6) DC Brake

P16.50–P16.56 DC brake function. It is classified as start DC brake and stop DC brake. This feature works only under V / F control mode.

Start DC brake: Set P16.50, P16.51, P16.52 values, which is used to add DC brake current to the motor that is in free slide till stop, enable motor to stop first and then to start.

Stop DC brake: Set P16.54, P16.55, P16.56 values, which is used to add DC brake current to the motor that is in deceleration, enable the motor to stop. The

specific settings are shown as below:

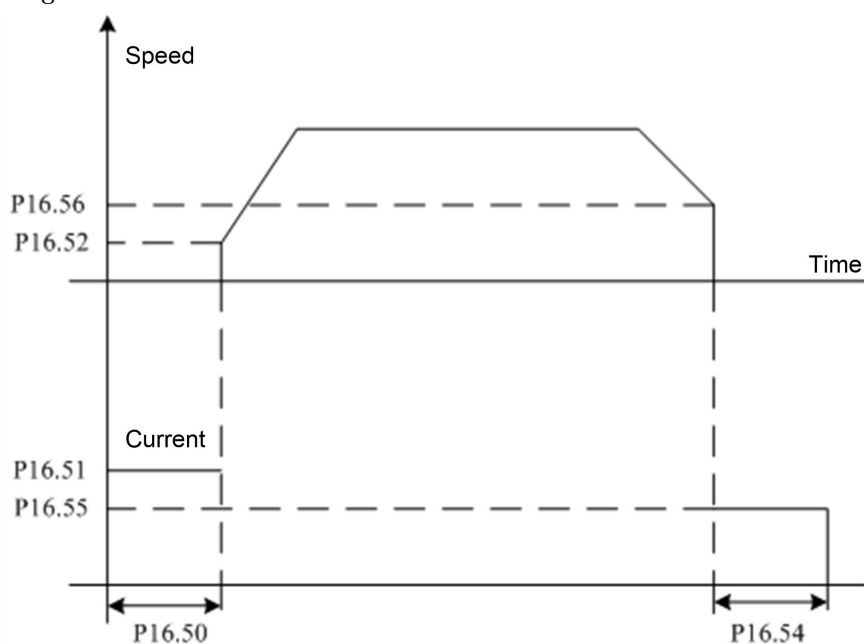

(7) Resonance suppression

P16.64 (stabilization suppression) is the parameters set to eliminate mechanical or electrical resonance automatically. If the setting value is not zero, the stability controller can eliminate resonance caused by mechanical or electrical reasons. If the setting value is zero, the controller would not act.

8.10 Motor vector control parameters

(1) Switch between torque and speed:

P20.0 represents the parameter value to be set for torque control and speed control switch.

When $P20.0 = 0$ and $P20.1 = 0$, $P20.2 = 0$, it is in speed control mode, it is impossible to switch into torque control mode under this setting.

When $P20.0 = 0$ and $P20.1 \neq 0$, $P20.2 \neq 0$, it is in torque control mode, it is impossible to switch into speed control mode under this setting.

When $P20.0 = 1$ and $P20.1 \neq 0$, $P20.2 \neq 0$, it is in torque control mode if the torque and speed switching signal is set as 1 while it is in speed control mode if the switching signal is set as 0.

When it is in torque control, if the motor output torque is greater than the load torque, the motor speed will gradually increase to balance value or limit

value; if the motor output torque is smaller than the load torque, the motor speed will gradually decrease to balance value or minus limit value. In order to ensure the torque control, it is necessary first to enable normal operation under P16.11 [1] S / L Vector Control or [2] CL Vector Control mode.

P20.3 fixed torque value setting: This parameter is valid only after setting parameter P20.1 as [4].

(2) Zero Torque:

This function is activated by DI or communication, and the given torque is set to 0 in torque control mode. When the signal is low, the inverter automatically switches to speed control mode and traces the current speed to given speed. Set P12.24 and P12.25 to 0 when enabling this function.

(3) Torque limitation:

P20.7 is the setting source for the torque limitation; the setting value is valid both in speed control and torque control modes. P20.8, P20.9 value is only valid when P20.7 = 1.

(4) Encoder direction

P20.15 encoder reverse phase sequence function: when the motor is forward turning, it enables encoder output A or B phase ahead. Such as if encoders A, B are reversed connected, or motor U, V, W phase are reversed connected, it may change the phase sequence by modifying the parameter without changing the wiring.

[0] When it is not enabled, the encoder rotation direction is consistent with the motor rotation direction;

[1] When it is enabled, if the encoder rotation direction is opposite to the motor rotation direction, the inverter can automatically mutually exchange the A-phase and B-phase identification functions.

(5) Synchronous compensation control:

When two motors are non-rigidly connected driving one load, adjust one of the motors speed, so that the two motors can maintain position balance function. This function is available only in closed-loop vector control, and must be synchronized with GDHF-PGD2 PG card.

Only one of the inverters controlling the two motors (inverter mounted with

GDHF-PGD2 synchronous PG card) need to have effective synchronous compensation control. When DI function "[10] hook mode" is valid or DP control "CW0.9 hook mode" is valid, set P20.26 and P20.27 values are greater than 0, the two motors are ON, and after the other motor speed is up to 2% of rated speed, the synchronous compensation control begins to operate.

When P20.34 is set to [0], the synchronal compensation control algorithm 1 controls the encoder pulse error of the two motors to minimum 0 pulses. When P20.26 and P20.27 is set to a value greater than 0, adjust the synchronization compensation control response. P20.26 is generally recommended to set to 50% ~ 100%, and P20.27 is set to 3% to 5%.

When P20.34 is set to [1], the synchronal compensation control algorithm 2 controls the encoder pulse error of the two motors to minimum 200 pulses. Since the control algorithm is internally fixed, P20.26 and P20.27 can just be set to any value greater than 0.

If the two inverters are Guide HF630 series, P20.34 is recommended to set [1]; if one is Guide HF630 series inverter, and the other one is the other brand inverter, P20.34 is recommended to set [0].

(6) DROOP control:

When two motors are rigidly connected driving one load, stabilize the motor torque to achieve load balancing capabilities between the two motors. The DROOP control function of the inverters controlling two motors must be valid. DROOP control decelerates the motor during over load torque, and accelerates it during low load to maintain load balancing. When P20.60 is set to 0, DROOP control is invalid. P20.61 is adjustable parameters of adjusting DROOP control response, increasing this setting when vibrating and oscillating.

(7) Master-Slave control1:

When two inverters control two rigid coupling motors (such as RTG hoisting mechanism、slewing mechanism), one of them is chosen as the master, which adopts speed control, the other is slave, which adopts torque control. The output torque of the master is transmitted to slave as the given torque of slave.

(8) Master-Slave control2:

When two inverters control two rigid coupling motors (such as RTG hoisting

mechanism、slewing mechanism), both inverters adopts speed control. One of them is chosen as master and the other is slave. The output torque of the master is transmitted to slave through AI, but not as the given torque of slave.

(9) Anti Grab Open Function

This function prevents grab opening, when two inverters are balancing load torque in air, and the driver return the handle to zero. The encoder wire of the supporting machine should be connected to the PGD2 card of the opening machine. The opening machine receives the the speed signals of two motors at the same time. The PLC activates this function after have closed grab and disable this function after have balanced load torque. This function is activated by DI or DP communication control word CW0.10.

(10) Start magnetic current:

P20.36 start magnetic current: It controls the basic limit of field during starting, and the start current can be reduced under vector control as shown below:

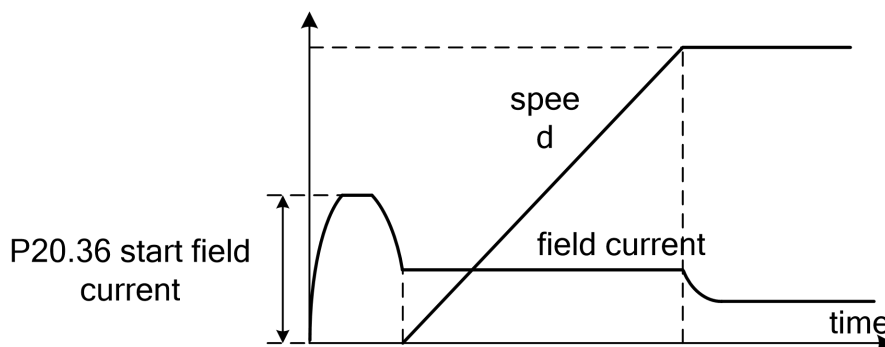

(11) Magnetic flux:

P20.37 ~ P20.40 is used to set the size of the magnetic field based on its corresponding speed, it is shown as below:

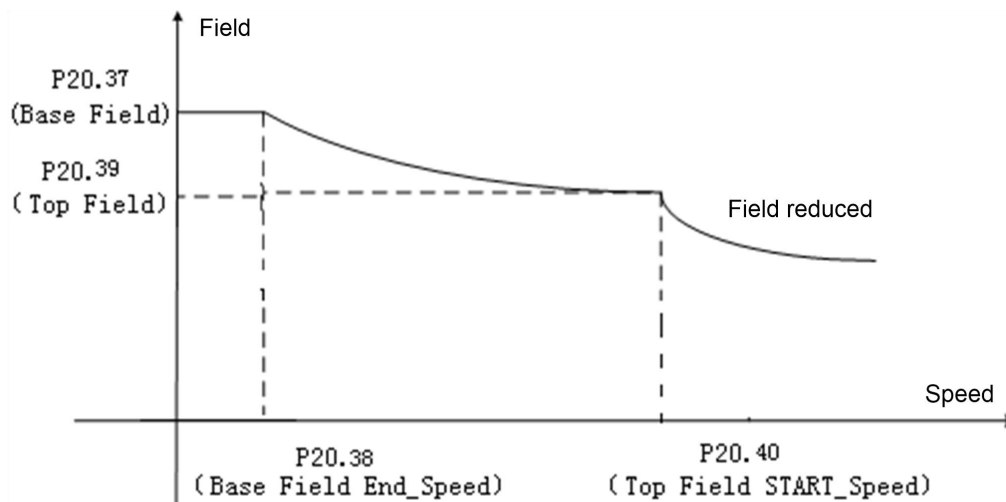

(12) Field discharge function:

P20.57, P20.58 and P20.59 are the field discharge functions which can demagnetize quickly. When P20.57 is set to 1, this function is enabled. P20.58 is the maximum current value of the magnetic field demagnetization phase. After demagnetization phase begins, the field discharge function stops when the magnetic field is less than the actual value of P20.59.

(13) Speed ring:

P20.55 speed tracking controller proportional gain: the high torque controller output increases with the speed error increases. If the set value is relatively high, then the speed deviation decreases rapidly.

P20.59 speed tracking controller integral gain: it refers to the time spent on speed controller output rated torque command during constant velocity error persists. If the set value is relatively low, then the speed deviation decreases rapidly.

The speed controller gain set by percentage (%) can be obtained by auto-tuning. Speed control block is shown as follows:

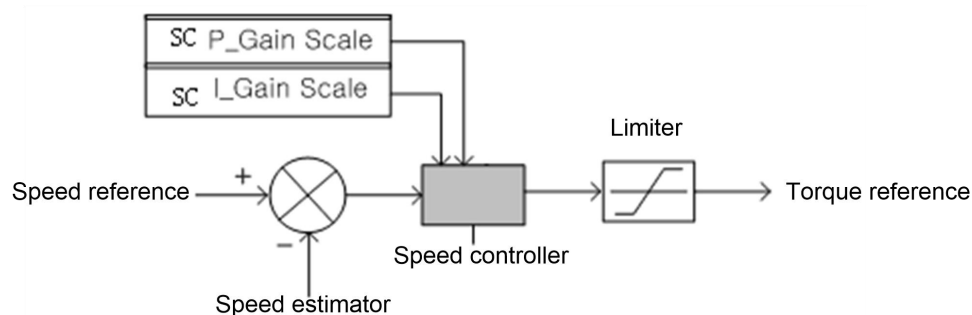

(14) Current ring:

P20.62 and P20.63 represent the current loop proportional and integral gain. The current controller gain is set with percentage (%) value, which can be obtained by auto-tuning. Vector control block is shown as follows:

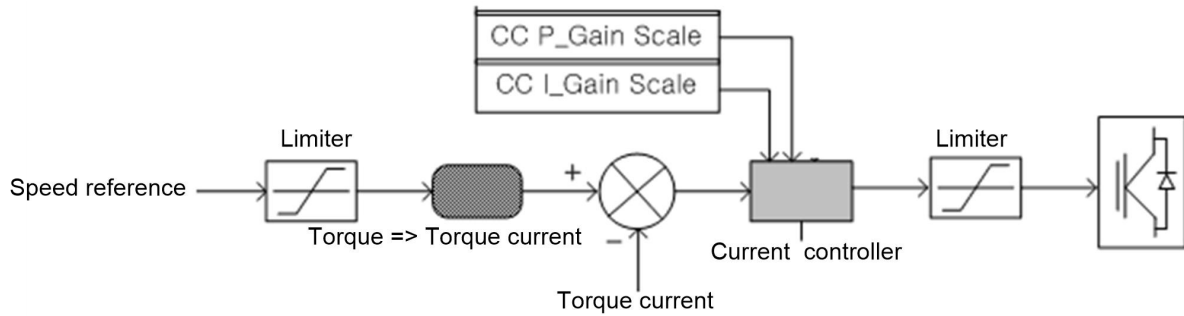
**8.11 Advanced application**

During operation, if problems occur, such as vibration or imbalance that caused by the control performance failure, please adjust the corresponding control mode parameters in the following table, which only lists some frequently modified parameters.

Control mode	Parameter name	Performance	Default value	Recom. value	Adjustment method
V/F control	P16.64 V/F Stabilization @Gain	To suppress medium speed (10 ~ 40HZ) disorderly adjustment and vibration	100	80~150	Reduce the value of this parameter for improving insufficient heavy load torque; Increase the value of this parameter for improving vibration occurs at light load.
	P16.12 PWM @Carrier Frequency	To improve motor magnetic noise.	Power dependent	Different values for different power values (Redo auto-tuning if the carrier frequency is changed)	Increase the value of this parameter for reducing motor magnetic noise; Reduce the value of this parameter for improving vibration occurs at low/medium speed.
	P16.15 Torque Compensation	To improve the motor torque.	Disable	Disable	Enable this parameter for improving insufficient heavy load torque and low

					speed. Disable this parameter for improving vibration occurs at light load.
	P16.26 V/F DC offset	To improve low speed torque.	0.75	0.5~1.2	Increase the value of this parameter for improving insufficient low speed torque; Reduce the value of this parameter for improve great surge at start.
	P7.0 Current Limit	To improve current surge.	150	150~220	Increase the value of this parameter for improving motor slow respond speed and imbalance at heavy load; Reduce the value of this parameter for improve great current surge at light load.
Vector control	P16.12 PWM @Carrier Frequency	To improve motor megnatic noise.	Power dependent	Different values for different power values (Redo auto-tuning if the carrier frequency is changed)	Increase the value of this parameter for reducing motor megnatic noise; Reduce the value of this parameter for improving vibration occurs at low/medium speed.
	P7.0 Current Limit	To improve current surge.	150	150~220	Increase the value of this parameter for improving motor slow responde speed and imbalance at heavy load; Reduce the value of this parameter for improve motor great current surge at light load.
	P20.43 Load Detection Time	To improve motor vibration and imbalance.	75	50~100	Increase the value of this parameter for improving motor vibration at load condition; Reduce the value of this parameter for improve motor torque slow respond at load vary condition.

	P20.56 Ki @Spd_Ctrl	To improve speed and torque respond, to suppress vibration and disorderly adjustment.	100	80~150	Increase the value of this parameter for improving low speed and slow torque respond; Reduce the value of this parameter for improve great surge at start.
--	------------------------	---	-----	--------	---

9. Abnormality solutions and inspection

To protect equipment, the inverter has over current, over voltage, under voltage, etc protection functions. When protection function is activated, the inverter output will be cut off and the motor will stop until a compulsory reset (RESET) is performed.

9.1 Alarm codes

The alarm codes will be shown in stop status.

Codes	Alarm information	Alarm causes	Measurements
W01	SYS_NOT_RDY	The inverter is not ready when it is energized.	Confirm the inverter input voltage and bus voltage.
W02	NO_DRV_ENABLE	When set digital terminals as [Inverter ENABLE], its corresponding conditions are not satisfied. There is no signal in corresponding communication control word.	Confirm the digital input parameter of parameter group P3, and its corresponding external electric relay and wiring. Confirm the communication word status.
W03	LOCAL_EM	When set digital terminals as [Local_Emergency], its corresponding conditions are not satisfied.	Confirm the digital input parameter of parameter group P3, and its corresponding external electric relay and wiring.
W04	REMOTE_EM	When set digital terminals as [Remote_Emergency], its corresponding conditions are not satisfied.	Confirm the digital input parameter of parameter group P3, and its corresponding external electric relay and wiring.
W06	OT	Overheat in inverter. The temperature of heatsink has reached the value of P7.14(Over Temperature Trip).	Confirm the casing temperature, cooling fan and load current.
W09	P/B ALARM	DP Card communication external alarm.	Confirm the status of DP communication corresponding control position.
W10	MODBUS ALARM	Modbus communication external alarm.	Confirm the status of Modbus corresponding control

Codes	Alarm information	Alarm causes	Measurements
			position.
W15	PARAMETER ERROR	Fault in parameter settings	Confirm whether the parameter setting is out of range.
W18	Temp_Sensing Fail	Fault and warning of temperature sensing.	Confirm temperature sampling cable; Confirm the communication between power panel and control panel; Confirm the power panel is normal.
W20	SLV_NOT_RDY	There is abnormality in slave inverter during parallel running.	Confirm the parallel running control line, whether the slave inverter is in normal state.
W21	SLV1_CAN_ERR	There is abnormality in slave 1 communication during parallel running.	Confirm the parallel running communication line, whether the slave inverter is in normal state.
W22	CAN_SLAVE_2	Communication error from slave 2 during parallel operation	Confirm if the parallel communication line and slave 2 are communicating normally
W23	CAN_SLAVE_3	Communication error from slave 3 during parallel operation	Confirm if the parallel communication line and slave 3 are communicating normally
W24	CAN_SLAVE_4	Communication error from slave 4 during parallel operation	Confirm if the parallel communication line and slave 4 are communicating normally
W25	CAN_SLAVE_5	Communication error from slave 5 during parallel operation	Confirm if the parallel communication line and slave 5 are communicating normally
W26	CAN ERROR	CAN slave message error	Refer to W21-W25

9.2 Error codes

The error codes will be shown in running status.

Error code	Error information	Error causes and measurment
[E051]	U phase ERR_UT not reset	Detect U phase IGBT failure after rest of E152 and reboot. Confirm the IGBT is normal; Confirm the IGBT drive wire and drive circuit is normal; Power on again after power failure.
[E053]	V phase IGBT failure	Detect V phase IGBT failure after rest of E154 and reboot. Confirm the IGBT is normal; Confirm the IGBT drive wire and drive circuit is normal; Power on again after power failure.
[E054]	W phase IGBT failure	Detect W phase IGBT failure after rest of E155 and reboot. Confirm the IGBT is normal; Confirm the IGBT drive wire and drive circuit is normal; Power on again after power failure.
[E056]	ERR_SLAVE_FAULT not reset	Confirm the slave inverter is normal; Slave inverter power on again after power off.
[E057]	Failure of internal brake unit	Detect brake unit IGBT failure after rest of E157 and reboot. Confirm the IGBT is normal; Confirm the IGBT drive wire and drive circuit is normal; Power on again after power failure.
[E100]	Overvoltage	DC bus voltage exceeds upper limit Check braking resistor and wiring
[E105]	Undervoltage	DC bus voltage is lower than lower limit Input voltage drop will cause the bus voltage drops to the limit values or the input voltage phase loss; Confirm the input voltage; Confirm the inverter input side magnetic contactor; Check the parameter P7.13 (bus undervoltage)
[E106]	Brake abnormal 1	Check whether DI wiring are normal. Check whether the brake is normal.
[E107]	Brake abnormal 2	Check whether DI wiring are normal. Check whether the brake is normal.

[E108]	DC switch open	Check whether DC switch and its wiring are normal.
[E109]	Failure of 15V power supply	Detect failure of 15V power supply Check whether the power 15V and its wiring are normal.
[E110]	Overcurrent	Output current to motor exceeds upper limit Check motor load. Check motor and wiring Check encoder and its wiring.
[E111]	Overload	Output current to motor is bigger than motor nominal current for long time. The inverter output current exceeds P7.48 (Over-Loaded Current) value. and the time exceeds P7.49 (OL Time) value. Check the motor load. Check the load current. Confirm parameter P7.48, P7.49. Confirm whether the motor and its wiring are normal.
[E112]	Short circuit to earth	Short circuit between output and earth Confirm parameter P7.8. Confirm whether the motor is short circuited. Confirm that the inverter is properly grounded. Confirm whether the current sensor wiring is normal.
[E113]	Loss of input phase	Detect loss of phase of input power supply Confirm whether the inverter input wiring is normal. Confirm whether the linear filtering control board control cable is properly connected.
[E114]	Loss of output phase	Detect loss of phase of output Check motor cable and motor.
[E115]	Overspeed	Motor speed is over upper limit Motor speed exceeds parameter P7.19 value. Confirm parameter P7.19. Confirm whether the encoder is good and the circuit is not interfered.
[E116]	SLVC Fail	Confirm whether the acceleration and deceleration time is too short. Confirm the parameter P7.23

[E117]	MOTOR STALL	Motor current increases too quick Check the brake connection. If there is encoder connection, confirm whether the encoder connection and settings P20.14 and P20.15 are correct.
[E118]	Failure encoder	Detect abnormal signal of encoder Check electrical connection of encoder.
[E119]	Abnormal speed	Speed gap is too big between measured speed and speed reference. Check electrical connection of encoder.
[E120]	Overheat of drive IGBT	Temperature of drive IGBT is too high Confirm the external and internal temperature. Confirm the inverter cooling fan. Check the load current.
[E138]	TEMP_SENSING FAIL	Abnormal signal of temperature sensor Check cable connection of temperature sensor.
[E139]	Failure pre-charge	abnormal charge to drive capacitor when powered on. Confirm input power voltage Check circuit for charge (charge contact, pre-charge resistor, etc).
[E152]	U phase IGBT failure	Failure of U phase IGBT Confirm the IGBT is normal; Confirm the IGBT drive wire and drive circuit is normal; Confirm whether the output wiring or motor is normal.
[E154]	V phase IGBT failure	Failure of V phase IGBT Confirm the IGBT is normal; Confirm the IGBT drive wire and drive circuit is normal; Confirm whether the output wiring or motor is normal.
[E155]	W phase IGBT failure	Failure of W phase IGBT Confirm the IGBT is normal; Confirm the IGBT drive wire and drive circuit is normal; Confirm whether the output wiring or motor is normal.

[E156]	Hardware overcurrent	Output current exceeds limit of hardware Confirm the acceleration/deceleration time. Check whether the motor and its wiring are normal. Check whether the output current of inverter is normal.
[E157]	Failure internal braking unit	IGBT failure of braking unit Confirm whether the power element is normal. Confirm whether the power element inverter wire and its inverter circuit are normal.
[E160]	SLAVE FAULT	Confirm whether there is fault in the slave inverter.
[E161]	SLV_NOT_RDY	Confirm whether the slave inverter running conditions are satisfied.
[E162]	SLV1_CAN_ERR	Confirm whether the parallel running optical cable and slave inverter communication is normal.
[E167]	Failure CAN communication	Detect error during CAN communication Confirm whether the inverter communication is normal.
[E170]	MOTOR TUNING FAIL	Failed during motor tuning Confirm motor nominal data.
[E180]	Failure DP communication	DP communication failed Confirm whether the communication card connection is normal. Confirm whether the communication configuration is correct.
[E181]	Warning DP communication	Warning occurs during DP communication Confirm the status of communication control word CW0.4.
[E190]	User customized error	No brake feedback change signal received in set time period Check setup of brake micro switch Check wiring of brake micro switch Check if the micro switch can work properly.
[E200]	Error local emergency stop	Receive signal from the terminal which is set for local emergency stop. Check the wiring and circuit to this terminal.
[E201]	Error remote emergency stop	Receive signal from the terminal which is set for remote emergency stop. Check the wiring and circuit to this terminal.
[E202]	Failure Modbus communication	Receive signal from control word CW0.4 of MODBUS communication. Check communication status.

[E203]	DRIVE DISABLED	No signal receive on enable terminal Check communication and wiring.
[E210]	Panel Error	Abnormal communication between panel operator and drive Check the connection between panel operator and drive.
[E220]	MEMORY CRC ERR	Error detected during CRC verification of memory unit Replace control plate.
[E221]	PARAMETER ERROR	Confirm the parameter settings meet the requirement.

9.3 Error diagnosis

Error		Inspection items	Measurements
Motor no rotation	No inverter output	<ul style="list-style-type: none"> •Whether the digital input terminals are well distributed. •Whether the running command signal is ON. • Whether forward or reverse terminals are well contacted with COM terminals. 	<ul style="list-style-type: none"> • Confirm that the digital terminals are well distributed •The running command signal is ON. •Confirm the forward and reverse terminals are well connected with COM terminals (Select terminal mode).
		<ul style="list-style-type: none"> •Whether the input 3P power supply is normal. 	<ul style="list-style-type: none"> • Confirm the tighten state of terminal screws. • Measure the input 3P terminal voltage.
		<ul style="list-style-type: none"> •Whether the operation panel power light is ON. If yes, then confirm whether the running signal light is ON. 	<ul style="list-style-type: none"> •Re-plug the wire if the operation panel power light is not ON. Please consult the agent or our company if still no improvement after re-plug. • If the operation panel power light is ON, but the running signal light is off, please give a run command once more.
		<ul style="list-style-type: none"> •Whether warnings or error messages are displayed on the operation panel. 	<ul style="list-style-type: none"> •Re-run after reset.
		<ul style="list-style-type: none"> •Whether the inverter operation mode and command value are correct. 	<ul style="list-style-type: none"> •Confirm the inverter operation mode parameters.
	Inverter With output	<ul style="list-style-type: none"> •Whether the motor is in “BRAKE ON” state or whether the load is too heavy. 	<ul style="list-style-type: none"> •Release the brake and reduce the load. •Try running the motor alone.
		<ul style="list-style-type: none"> •When a brake is attached to the motor, whether the brake action is 	<ul style="list-style-type: none"> •Release the brake carefully and re-run.

Error	Inspection items	Measurements
	normal.	
	<ul style="list-style-type: none"> •Whether the motor wiring is normal or whether there is phase loss on motor. 	<ul style="list-style-type: none"> •Confirm the inverter output and motor output connection status.
	<ul style="list-style-type: none"> •Whether the inverter output current value is greater than or equal to the current limitation value. 	<ul style="list-style-type: none"> • Confirm the correct parameter settings and try adjusting acceleration and deceleration time to increase the speed slowly.
	<ul style="list-style-type: none"> • When a magnetic contactor is equipped between the inverter and the motor, whether the contactor is ON. 	<ul style="list-style-type: none"> • Confirm that the magnetic contactor is ON and its wiring state.
Motor rotates reversely.	<ul style="list-style-type: none"> • Whether the wiring between the inverter output 3P and the motor is normal. 	<ul style="list-style-type: none"> •Exchange V phase and W phase.
	<ul style="list-style-type: none"> • Whether the terminals that connected to control circuit and its parameter settings are normal. 	<ul style="list-style-type: none"> • Confirm the wiring of forward/reverse terminals and parameter values.
The motor speed can not be increased.	<ul style="list-style-type: none"> •Whether the load is too heavy. 	<ul style="list-style-type: none"> •Reduce the load. •If the motor is overloaded, then start its limitation function to reduce the speed to a value that is less than the setting value. •Release the load or reduce the load.
	<ul style="list-style-type: none"> •Whether the speed command signal is normal. 	<ul style="list-style-type: none"> • Confirm the control circuit wiring or its signal and the setting value.
There is motor shaking during running.	<ul style="list-style-type: none"> •Whether the load varieties are too large. •Whether the input voltage changes too much. • Whether it occurs in a certain frequency. 	<ul style="list-style-type: none"> •Raise the motor and the inverter power to the next higher level. •Reduce the load and input voltage changes • Adjust slightly the output frequency setting values.
Motor current exceeds the rated values.	<ul style="list-style-type: none"> • The voltage drops when input voltage. 	<ul style="list-style-type: none"> •Confirm the inverter input power supply.
	<ul style="list-style-type: none"> •Whether the load is too heavy. 	<ul style="list-style-type: none"> •Release or reduce the load.
	<ul style="list-style-type: none"> •Whether the motor is in “BRAKE ON” state. 	<ul style="list-style-type: none"> •Release the brake on the motor.
	<ul style="list-style-type: none"> • Whether the load is dynamic(the weight is changable) 	<ul style="list-style-type: none"> • Re-confirm the inverter power calculation.
<ul style="list-style-type: none"> •Whether the motor have completed the auto-tuning normally. 	<ul style="list-style-type: none"> •Redo motor auto-tuning. 	

10. Maintenance



Danger

- 1. Do not touch the inverter terminals, which carry high voltage.**
Risk of electric shock.
- 2. Finish installing the terminal cover before energizing, when removing the cover, the power must be shut off.**
Risk of electric shock.
- 3. Maintenance and inspection can be performed only after turning off the main circuit power supply and confirmation of the LED totally out.**
Danger of residual voltage on electrolytic capacitors.
- 4. Non-professional and technical personnel are not allowed to perform maintenance or inspection work.**
Risk of electric shock.



Notice

- 1. CMOS integrated circuit is mounted on keypad board, control circuit board and the inverter circuit board, please pay special attention during using.**
If touch the circuit board directly with fingers, the electrostatic induction may damage the integrated chip on the circuit board.
- 2. Do not change the wiring and remove the terminal wiring when it is energized**
Risk of electric shock.
- 3. Do not check the signals during running.**
It may damage the device.

10.1 Maintenance instructions

As the inverter is a typical product that contains both power electronics technology and microelectronics technology, it has dual characteristics of industrial equipment and microelectronic devices. Various faults may occur to inverter due to changes the environment, such as temperature, humidity, smoke,

etc, as well as the aging of the internal components. Therefore, in order to obtain long-term normal operation of the inverter, it is necessary to perform routine checks and regular maintenance in storage and operation (at least once of every six months).

10.2 Routine maintenance

In order to prevent the inverter failures and to ensure normal operation and prolong the service life, it is necessary to perform routine maintenance for the inverter. The routine maintenance contents is shown as follows:

Check items	Check contents	Criteria
Running environment	1. Temperature, humidity 2. Dust, gases	1. When temperature is over 40 °C, stop the machine or low the ambient temperature. Humidity should be less than 95% and no frost. 2. There should be no smell, no flammable and explosive gases.
Cooling system	1. Installation environment 2. Fans in inverter main body	1. Good ventilation in the installation environment, and no block in the air duct. 2. Fans in inverter main body run normally without abnormal noise.
Inverter main body	1. Vibration, over-temperature 2. Noise 3. Conductor and terminals	1. The vibration is steady, the air duct temperature is normal. 2. There is no abnormal noise and no smell. 3. The tightening screws are firmly fixed.
Motor	1. Vibration, over-temperature 2. Noise	1. Steady running and normal temperature. 2. No abnormal and uneven noise.
Input/output parameters	1. Input voltage 2. Output current	1. The input voltage is within a standard range. 2. The output current is lower than the rated values.

10.3 Periodic maintenance

To prevent failure of the inverter and to ensure its high performance and stable operation for a long time, the user must periodically (within six months) inspect the inverter. The inspection items are as follows:

Inspection items	Inspection contents	Measurements
External terminal screws	Whether the screws are loose.	Tight the screws.
Power components	Dust and dirt	Use dry compressed air to clean the dust and dirt thoroughly.
radiator	Dust and dirt	Use dry compressed air to clean the dust and dirt thoroughly.
Electrolytic capacitor	Whether there is color change or there is peculiar smell.	Replace the electrolytic capacitor.
Fan	Abnormal noise and vibration. Whether the accumulative using time is over 20,000 hours.	1. Clean the fan. 2. Change the fan.
PCB board	Dust and dirt	Use dry compressed air to clean the dust and dirt thoroughly.

10.4 Displacement of wearing elements

In order to guarantee long-time, safe, and trouble-free operation of the inverter, consumable components such as inverter fan and electrolytic capacitor should be regularly replaced. Consumable parts replacement time is as follows:

Fan: It must be replaced after using over 20,000 hours.

Electrolytic capacitors: It must be replaced after using over 30,000 to 40,000 hours.

10.5 Storage and guarantee

Special attention should be paid as follows during inverter's temporary or long-term storage:

- (1) Avoid storing the inverter in places with high temperature, moisture or vibration and metal dusts. Ensure good ventilation.
- (2) If the inverter will be not used for a long time, it should be energized once of every six months to restore electrical characteristics of the filter capacitor and checked for normal functions. During inverter energization, the voltage should be gradually increased by an

autotransformer, and the energization time is not less than 5 hours.

During the guarantee period, maintenance fee should be borne by the users to repair the problems caused by the following reasons:

- (1) Failures caused by operations that disobey the operating manual or exceed using standards in the specification.
- (2) Faults caused by self-repair and modification without permission.
- (3) Faults caused by improper storage.
- (4) Faults caused by abnormal use of the inverter.
- (5) Faults caused by machine damages due to fire, salt corrosion, gas corrosion, earthquakes, storms, floods, lightning, abnormal voltage or other reasons caused by force majeure.

Our company offers a lifetime paid service even if the guarantee period expires.

GUIDE Inverter HF630-L (MT) Series

Technical Manual

Version: 1.06

GUIDE

Precautions

1. Make sure to read this manual before using the inverter products.
2. Please ask for professional commissioning and wiring for safety.
3. The contents of this manual is subject to change without notice.

Wuhan Guide Technology Co., Ltd.

Address: No. 6, WUT (Wuhan University of Technology) Science and Technology Park,
Wuhan East Lake High-tech Development Zone, Wuhan, Hubei, P.R. China

Postcode: 430223

TEL: 86-27-87927230

E-mail: shfw@gdetec.com

Website: www.gdetec.com

After-sales service line: 400-0077-570

Wuhan Guide Technology Co., Ltd.